

Dear Customer,

We are very pleased that you have chosen a **HYMERCAR** leisure vehicle and would like to thank you for the trust you have shown in our company.

This instruction manual is intended to help you get to know and use your new vehicle. **It is essential that you read and comply with the safety instructions in chapter 2.**

Don't hesitate to contact our **HYMERCAR** service centres if you have any questions. Their staffs are fully conversant with your vehicle and will be pleased to help in any way they can. Our list of **HYMERCAR** service centres in Europe is updated regularly. You can obtain a copy of the latest edition from your **HYMERCAR** dealer.

In addition to this instruction manual you will also receive the separate instruction manuals for the base vehicle and the various built-in appliances.

We are sure that you will get a lot of enjoyment from your vehicle. Have a good trip!

You will also find **HYMER GmbH & Co. KG** on the Internet at: <http://www.hymer.com>.

Yours, **HYMER GmbH & Co. KG**



**Customer address**

Surname, Christian name: \_\_\_\_\_

Street, no.: \_\_\_\_\_

Postal code, town: \_\_\_\_\_

Country: \_\_\_\_\_

**Vehicle data**

Model: \_\_\_\_\_

Key no.: \_\_\_\_\_

Serial number: \_\_\_\_\_

Chassis number: \_\_\_\_\_

Initial registration: \_\_\_\_\_

**Dealer data**

Dealer number: \_\_\_\_\_

Date of hand-over: \_\_\_\_\_

**Notification of delivery**

To be completed on the date the vehicles is handed-over by the selling dealer, a copy being returned to the manufacturer.

**Confirmation:**

I have today received the documents for the stated model.

Date: \_\_\_\_\_

\_\_\_\_\_  
Selling dealer's signature and stamp\_\_\_\_\_  
Customer's signature

**Please paste the warranty  
stamp in here.**



<b>1</b>	<b>Introduction</b> .....	<b>11</b>	5.3	240 V connection	43
1.1	General	12	5.4	Refrigerator	43
1.2	Environmental tips	12	5.5	Awning	43
<b>2</b>	<b>Safety</b> .....	<b>15</b>	<b>6</b>	<b>Living</b> .....	<b>47</b>
2.1	Fire prevention	15	6.1	External doors	47
2.1.1	Avoidance of fire risks	15	6.2	External flaps	47
2.1.2	Fire-fighting	15	6.2.1	External flap Thetford cassette	47
2.1.3	In case of fire	15	6.3	Ventilation	48
2.2	General	15	6.4	Windows	48
2.3	Road safety	16	6.4.1	Hinged window	49
2.4	Towing	17	6.4.2	Roman shade and insect screen	51
2.5	Gas system	18	6.4.3	Roman shades for windscreen, driver's window and front passenger's window	51
2.5.1	General instructions	18	6.5	Skylights	52
2.5.2	Gas bottles	19	6.5.1	Skylight with snap latch	53
2.6	Electrical system	20	6.5.2	Hinged skylight	54
2.7	Water system	20	6.6	Elevating roof	55
<b>3</b>	<b>Before the journey</b> .....	<b>21</b>	6.7	Rotating seats	59
3.1	Start-up	21	6.8	Storage spaces	60
3.2	Payload	21	6.8.1	Storage compartment in double floor	61
3.2.1	Terms	22	6.9	Tables	62
3.2.2	Calculating the payload	24	6.9.1	Suspension table, folding	62
3.2.3	Loading the vehicle correctly	25	6.9.2	Suspension table with separable support leg	63
3.2.4	Bike rack	27	6.9.3	Folding worktop	64
3.2.5	Roof load	28	6.10	TV unit	65
3.3	Towing	28	6.11	Smoke alarm	66
3.4	Caravan coupling	29	6.12	Beds	67
3.5	Electrically operated entrance step	29	6.12.1	Rear bed	67
3.6	Television	30	6.12.2	Bed in the elevating roof	68
3.7	Kitchen area	30	6.12.3	Additional bed (conversion of the seating group)	69
3.8	Gas regulator	30	<b>7</b>	<b>Gas system</b> .....	<b>71</b>
3.9	Snow chains	31	7.1	General	71
3.10	Road safety	32	7.2	Gas bottles	72
<b>4</b>	<b>During the journey</b> .....	<b>35</b>	7.3	Gas isolator taps	73
4.1	Driving the motorhome	35	7.4	Gas pressure regulating system DuoControl CS	74
4.2	Driving speed	35	<b>8</b>	<b>Electrical system</b> .....	<b>77</b>
4.3	Brakes	36	8.1	General safety instructions	77
4.4	Seat belts	36	8.2	Terms	77
4.4.1	General	36	8.3	12 V power supply	78
4.4.2	Fastening the seat belt correctly	36	8.3.1	Starter battery	78
4.5	Child restraint systems	37	8.3.2	Living area battery	80
4.6	Driver's seat and front passenger's seat	38	8.3.3	Energy balance of the living area battery	82
4.7	Headrests	40	8.3.4	Installation of converter	82
4.8	Seating arrangement	40	8.4	Transformer/rectifier (EBL 30)	82
4.9	Roman shades for driver's window and front passenger's window	40	8.4.1	Battery cut-off switch	84
4.10	External doors	41	8.4.2	Battery selector switch	84
4.11	Refuelling	41	8.4.3	Battery monitor	84
4.12	Towing	42			
<b>5</b>	<b>Pitching the motorhome</b> .....	<b>43</b>			
5.1	Handbrake	43			
5.2	Entrance step	43			

8.4.4	Charging the battery	84	10.5	Toilet	127
8.4.5	Retrofitting additional 12 V appliances	85	10.5.1	Swivel toilet	128
8.5	Panel (LT 453)	85	10.5.2	Toilet with fixed seat	128
8.5.1	12 V main switch	86	10.5.3	Emptying the sewage tank	129
8.5.2	Water pump switch	86	10.5.4	Winter operation	130
8.5.3	LED array for battery voltage	86	10.5.5	Temporary lay-up	131
8.5.4	LED array for tank fill level	88	10.6	Installation positions	131
8.6	240 V power supply	88	<b>11</b>	<b>Care</b>	<b>133</b>
8.6.1	240 V connection (CEE socket outlet)	89	11.1	External care	133
8.6.2	Connecting the 240 V power supply	89	11.1.1	General	133
8.7	Fuses	90	11.1.2	Washing with a high-pressure cleaner	133
8.7.1	12 V fuses	90	11.1.3	Washing the vehicle	134
8.7.2	240 V fuse	92	11.1.4	Windows of acrylic glass	134
8.8	Position of the electric components	92	11.1.5	Add-on parts made of glass-fibre reinforced plastic (GRP)	134
8.9	Circuit diagrams	93	11.1.6	Underbody	135
8.9.1	Block diagram 240 V	93	11.1.7	Engine compartment	135
8.9.2	Block diagram 12 V	94	11.1.8	Windscreen washer system and windscreen wipers	136
<b>9</b>	<b>Appliances</b>	<b>95</b>	11.1.9	Air conditioning unit	136
9.1	General	95	11.1.10	Entrance step	137
9.2	Heater and boiler	95	11.2	Interior care	137
9.2.1	To heat properly	96	11.3	Kitchen installation	138
9.2.2	Hot-air heater and boiler with CP plus digital operating unit	97	11.3.1	General notes on care	138
9.2.3	Wall flue	102	11.3.2	Stainless steel surfaces	139
9.2.4	Eberspächer hot-air heater	102	11.3.3	Refrigerator	139
9.3	Dometic FreshLight air conditioning unit	104	11.4	Cushions	140
9.4	Boiler	108	11.5	Water system	141
9.4.1	Truma boiler	109	11.5.1	Cleaning the water tank	141
9.5	Gas cooker	110	11.5.2	Cleaning the water pipes	142
9.6	Gas oven (Dometic)	112	11.5.3	Disinfecting the water system	142
9.7	Refrigerator	113	11.5.4	Cleaning the waste water tank	143
9.7.1	Operation (Thetford T1000)	113	11.6	Winter care	143
9.7.2	Operation (Cruise 85)	115	11.7	Lay-up	143
9.7.3	Refrigerator door locking mechanism	116	11.7.1	Temporary lay-up	143
<b>10</b>	<b>Sanitary fittings</b>	<b>119</b>	11.7.2	Winter lay-up	145
10.1	Water supply, general	119	11.7.3	Starting up the vehicle after a temporary lay-up or after lay-up over winter	146
10.2	Water system	120	<b>12</b>	<b>Customer service and maintenance</b>	<b>147</b>
10.2.1	Water tank	120	12.1	Inspection work	147
10.2.2	Filling the water system	120	12.2	Maintenance work	147
10.2.3	Topping up the water	122	12.3	Replacing bulbs, external	148
10.2.4	Draining water	123	12.4	Lighting for living area	148
10.2.5	Reducing the water quantity for mobile operation	123	12.5	Changing the battery of the smoke alarm	149
10.2.6	Emptying the water system	124	12.6	Spare parts	150
10.3	Waste water tank	125	12.7	Vehicle identification plate	151
10.4	Toilet compartment	126	12.8	Warning and information stickers	151
10.4.1	Wash basin	127	12.9	Dealers	152
			12.10	Replacement keys	152

---

<b>13</b>	<b>Wheels and tyres.....</b>	<b>153</b>
13.1	General .....	153
13.2	Tyre selection .....	154
13.3	Tyre specifications .....	155
13.4	Handling of tyres .....	155
13.5	Changing wheels.....	156
13.5.1	General instructions .....	156
13.5.2	Tightening torque .....	157
13.5.3	Changing a wheel .....	157
13.5.4	Changing a wheel with alloy wheel rims.....	158
13.6	Tyre pressure .....	158
13.6.1	Tyre pressure .....	159
<b>14</b>	<b>Troubleshooting .....</b>	<b>161</b>
14.1	Braking system .....	161
14.2	Electrical system .....	161
14.3	Gas system .....	163
14.4	Gas cooker/gas oven .....	164
14.5	Heater/boiler .....	164
14.5.1	Truma heater/boiler with operating unit CP plus .....	164
14.6	Truma boiler .....	166
14.7	Air conditioning unit.....	167
14.8	Refrigerator .....	168
14.8.1	Thetford T1000 .....	168
14.8.2	Cruise 85.....	169
14.9	Water supply .....	170
14.10	Body .....	171
<b>15</b>	<b>Special equipment .....</b>	<b>173</b>
15.1	Weight details for special equipment .....	173
<b>16</b>	<b>Technical data .....</b>	<b>175</b>
16.1	Technical data.....	175





**Observe the following instructions before first journey of the vehicle:**

- ▶ Re-tighten the wheel nuts/wheel bolts after 50 km (30 miles).
- ▶ Read the instruction manual to avoid personal and material damage.

**Observe the following instructions before each journey of the vehicle:**

- ▶ **Check the tyre pressures.**  
See Tyre pressure section.
- ▶ **Load the vehicle correctly. Observe the maximum permissible gross weight.**  
See Payload section.
- ▶ **Fully charge batteries before each journey.**  
See Starter battery and Living area battery sections.
- ▶ **In case of external temperatures below 0 °C first heat vehicle, then fill water system.**  
See Water supply/Filling the water tank section.
- ▶ **Gas bottles should only be transported within the designated gas bottle compartment and should be checked to be secure and in the off position prior to travelling.**
- ▶ **Keep forced ventilations clear.**  
See Skylights and Ventilation sections.
- ▶ **Before filling the vehicle with fuel switch off gas-operated appliances.**

**If there is any risk of frost, observe the following instructions:**

- ▶ **If there is any risk of frost, always heat the vehicle.**  
See Heater section.
- ▶ **If the vehicle is not being used when there is risk of frost, empty the entire water system. Make sure that the 12 V power supply on the panel is switched off. Otherwise, the water pump will overheat and may get damaged. Leave the water taps on in central position. Leave all drain cocks open. This will avoid frost damage to appliances and to the vehicle.**  
See Emptying the water system section.



**Please read this instruction manual completely before using the vehicle for the first time!**

Always keep this instruction manual in the vehicle. Also inform all other users of the safety regulations.



▶ The non-observance of this symbol can lead to personal injury.



▷ The non-observance of this symbol can lead to damage being caused to, or inside the vehicle.



▷ This symbol indicates recommendations or special aspects.



▷ This symbol indicates actions which lead to environmental awareness.

**This instruction manual contains sections which describe model-specific equipment or special equipment. These sections are not specially marked. It may be that your vehicle has not been fitted with this special equipment. In some cases, the actual equipment of your vehicle may therefore be different from that shown in some illustrations and descriptions.**

However, your vehicle may be fitted with other special equipment not described in this instruction manual.

Special equipment is described when an explanation is required.

Adhere to the instruction manuals which are separately enclosed.



▷ The details "right", "left", "front" and "rear" always refer to the vehicle in direction of travel.

▷ All dimensions and weight details are "approximate".

▷ The metric specifications are binding for physical dimensions.

Should the vehicle be subjected to damage due to a failure to follow the instructions in this instruction manual, then the warranty claim is deemed invalid.

Our vehicles are subjected to continuous development. Please understand that we reserve the right to alter the form, equipment and technology. Therefore, no claims can be made against the manufacturer as a result of the contents of this instruction manual. The equipment which was known and included at the time of going to press is described.

The reprinting, translation and copying, including extracts is not permitted without prior written authorisation from the manufacturer.

## 1.1 General

The vehicle is constructed in accordance with the latest technology and the recognised safety regulations. Nevertheless, personal injury may result and the vehicle may be damaged if the safety instructions in this instruction manual are not followed.

Before using the vehicle for the first time, equip it with the legally prescribed equipment (e.g. first aid kit, warning vest, hazard warning triangle etc.). Observe the relevant equipment regulations when travelling abroad.

Only use the vehicle in a technically impeccable condition. Follow the instructions in the instruction manual.

Malfunctions which impair the safety of persons or the vehicle should be immediately remedied by qualified personnel. To avoid further damages, observe the duty to avert, minimise or mitigate loss for the user during faults.

Have the vehicle's braking and gas systems inspected and repaired by an authorised specialist workshop only.

Alterations to the body are only to be carried out with the authorisation of the manufacturer.

The vehicle is designed for the exclusive transport of persons. Luggage and accessories may only be transported up to the maximum permissible gross weight.

Observe the test and inspection periods stipulated by the manufacturer.

## 1.2 Environmental tips



- ▷ Be considerate of the environment.
- ▷ Remember that: All kinds of waste water and household waste are not to be disposed of in drains or in the open countryside.
- ▷ On board, collect waste water only in the waste water tank or – if necessary – in other containers designed for that purpose.
- ▷ Only empty the waste water tank and sewage tank at disposal stations, camping sites or caravan sites especially provided for this purpose. When stopping in towns and communities, observe the instructions at caravan sites or ask where there are disposal stations.
- ▷ Empty waste water tank as often as possible, even when it is not completely full (hygiene).

If possible, flush out waste water tank and, if necessary, drainage pipe with fresh water every time it is emptied.
- ▷ Never allow the sewage tank to become too full. Empty the sewage tank frequently, at the latest as soon as the filling level display lights up.
- ▷ Separate household waste according to glass, tin cans, plastic and wet waste also when on a journey. Enquire at the town or community authority about disposal points. Household waste is not to be disposed of in waste paper baskets which are situated at car parks.
- ▷ Empty waste bins as often as possible into the containers provided for this purpose. This helps to avoid unpleasant smells and an accumulation of rubbish on board.
- ▷ When parked, do not allow the engine to run more than necessary. When running idle, a cold engine releases more contaminants than usual. The running temperature of the engine is achieved more quickly whilst the vehicle is in motion.



- ▷ Use an environmentally-friendly WC chemical agent for the WC which can also be biologically degraded and only use small doses.
- ▷ When staying in towns and communities for long periods, search for parking areas which are specially reserved for motorhomes. Enquire at the town or community authority about parking spaces.
- ▷ Always leave the parking places in a clean condition.



## Chapter overview

This chapter contains important safety instructions. The safety instructions are for the protection of persons and property.

### 2.1 Fire prevention

#### 2.1.1 Avoidance of fire risks



- ▶ Never leave children in the vehicle unattended.
- ▶ Keep flammable materials clear of heating and cooking appliances.
- ▶ Never use portable heating or cooking appliances.
- ▶ Only authorised qualified personnel may make changes to the electrical system, gas system or appliances.

#### 2.1.2 Fire-fighting



- ▶ Always carry a dry powder fire extinguisher in the vehicle. The fire extinguisher must be approved, tested and close at hand.
- ▶ Have the fire extinguisher tested at regular intervals by authorised qualified personnel. Observe the date of testing.
- ▶ Always keep a fire blanket near the cooker.

#### 2.1.3 In case of fire



- ▶ Evacuate all passengers.
- ▶ Cut off the electrical power supply and disconnect from the mains.
- ▶ Close regulator tap on the gas bottle.
- ▶ Sound the alarm and call the fire brigade.
- ▶ Fight the fire if this is possible without risk.



- ▷ Acquaint yourself with the position and operation of the emergency exits.
- ▷ Keep escape routes clear.
- ▷ Observe the fire extinguisher instructions for use.

### 2.2 General



- ▶ The oxygen in the vehicle interior is used up by breathing and the use of gas operated appliances. That is why the used air must be replaced permanently. For this purpose, forced ventilation options (e.g. skylights with forced ventilation, mushroom-shaped vents or floor vents) are fitted to the vehicle. Never cover or block forced ventilations from the inside or outside with objects such as e.g. a winter mat. Keep forced ventilations clear of snow and leaves. There is a danger of suffocation due to increased CO<sub>2</sub> levels.
- ▶ Observe the headroom of the doors.



- ▷ As far as the fitted appliances (heater, cooker, refrigerator, etc.) and the base vehicle (engine, brakes, etc.) are concerned, the instruction manuals are authoritative. It is imperative that they be observed.
- ▷ Fitting accessories or special equipment can alter the dimensions, weight and road behaviour of the vehicle. Some of the parts must be entered in the vehicle papers.
- ▷ Only use wheel rims and tyres which are approved for the vehicle. Information concerning the size of the approved wheel rims and tyres is included in the vehicle documents or can be obtained from authorised dealers and service centres.
- ▷ Firmly apply the handbrake when parking the vehicle.
- ▷ If the maximum permissible gross weight of the vehicle exceeds 4 tonnes, a wheel chock must be used when parking on gradients. The wheel chock is provided as standard for vehicles with a maximum permissible gross weight exceeding 4 tonnes.



- ▷ When leaving the vehicle, it is imperative that all doors and windows are closed. If the vehicle is equipped with external flaps, these must also be closed.
- ▷ Always carry the legally prescribed equipment (e.g. first aid kit, warning vest, hazard warning triangle etc.) with you. The regulations of the host country apply when travelling abroad.
- ▷ The vehicle may only be driven by drivers who hold a driving licence which is valid for the respective vehicle class.
- ▷ When selling the vehicle, hand over all instruction manuals for the vehicle and the fitted appliances.

### 2.3 Road safety



- ▶ Before commencing the journey, carry out a functional check of indicating and lighting equipment, the steering and the brakes.
- ▶ If the vehicle has been stationary for a long period (approx. 10 months) have the braking and gas systems checked by an authorised specialist workshop.
- ▶ Before commencing the journey and after short interruptions of the journey, ensure that the entrance step is completely retracted.
- ▶ Before commencing the journey, close and lock the elevating roof.
- ▶ Before commencing the journey, open, lock and secure the shades situated on the windscreen and on the driver's and front passenger's windows.
- ▶ Before commencing the journey, rotate all swivel seats in the direction of travel and lock in position. During the journey, the swivel seats must remain locked in place in the direction of travel.
- ▶ Carefully store all moving parts and all loose objects before starting your journey.
- ▶ Before commencing the journey, secure the television.
- ▶ During the journey, persons are only to sit on the permitted seats (see chapter 4). The authorised number of seats is stipulated in the vehicle documents.
- ▶ Seat belts must be worn by all passengers.





- ▶ Fasten your seat belts before the beginning of the journey and keep them fastened during the journey.
- ▶ When travelling, secure children under 13 years of age that are smaller than 150 cm, with a suitable and officially approved child restraint system.
- ▶ Only attach the child restraint system to seats that are specified for this purpose.
- ▶ The base vehicle is a commercial vehicle (small truck). Adjust your driving technique accordingly.
- ▶ In case of underpasses, tunnels or similar obstacles, note the total height of the vehicle (including the roof load).
- ▶ In winter, the roof must be free of snow and ice before commencing the journey.
- ▶ Check tyre pressure before a journey or every 2 weeks. Wrong tyre pressure causes excessive wear and can lead to damage or even to tyre burst. You can lose control of the vehicle (see section 13.6).
- ▶ Do not operate the heater at petrol stations. Danger of explosion!
- ▶ Do not operate the heater in closed spaces. Danger of suffocation!



- ▷ Before commencing the journey, distribute the payload evenly within the vehicle (see chapter 3).
- ▷ When loading the vehicle and when taking a rest from driving, in order to load luggage or food, for example, observe the maximum permissible gross weight and axle loads (refer to vehicle documents).
- ▷ Before commencing the journey, close and secure all drawers and flaps.
- ▷ Before commencing the journey, close windows and skylights.
- ▷ Before commencing the journey, close all external flaps (if present) and lock the flap locks.
- ▷ Before commencing the journey, remove external supports.
- ▷ Before commencing the journey, put the antenna in park position.
- ▷ During the initial journey and each time after changing a wheel, re-tighten the wheel bolts/wheel nuts after 50 km (30 miles). Subsequently inspect them at regular intervals in order to ensure that they are firmly seated.
- ▷ Tyres may not be older than 6 years as the material becomes brittle over time (see chapter 13).
- ▷ When using snow chains, the tyres, wheel suspension and steering are subjected to an additional load. When using snow chains, drive slowly (maximum speed 50 km/h) and only on streets which are completely covered with snow. Otherwise the vehicle could be damaged.

## 2.4 Towing



- ▶ Care is to be taken when connecting and detaching a trailer. Risk of accident and injury!
- ▶ No persons are to be between the motorhome and the trailer during positioning for connecting and detaching.

## 2.5 Gas system

### 2.5.1 General instructions



- ▶ The operator of the gas system is responsible for the performance of recurring inspections and for complying with the maintenance intervals.
- ▶ Before commencing the journey, when leaving the vehicle or when gas equipment is not in use, close all gas isolator taps and the main isolator tap on the gas bottle.
- ▶ All gas-operated devices (heater, cooker, oven, grill, refrigerator - depending on the equipment) must be switched off for refuelling, on ferries or in the garage. Danger of explosion!
- ▶ Do not use gas-operated devices in closed spaces (e.g. garages). Danger of poisoning and suffocation!
- ▶ Only have the gas system maintained, repaired or altered by an authorised specialist workshop.
- ▶ Have the gas system checked by an authorised specialist workshop according to the national regulations before commissioning. This also applies for not registered vehicles. For modifications to the gas system have the gas system immediately checked by an authorised specialist workshop.
- ▶ The gas pressure regulator, the gas tubes, and the exhaust gas pipes must also be inspected. The gas pressure regulator and the gas tubes must be replaced observing the nationally defined deadlines (the latest after 10 years). The vehicle owner is responsible for seeing that this is carried out.
- ▶ In case of a defect of the gas system (gas odour, high gas consumption) there is danger of explosion! Close regulator tap on the gas bottle immediately. Open doors and windows and ventilate well.
- ▶ If the gas system is defective: Do not smoke; do not ignite any open flames, and do not operate electric switches (light switches etc.). Check the tightness of gas-conducting parts and lines with leakage search spray. Do not check with an open flame.
- ▶ Only the stipulated devices may be connected to internal connections. Do not operate any device outside the vehicle if it is connected to an internal connector.
- ▶ Before using the cooker make sure that there is sufficient ventilation. Open a window or the skylight.
- ▶ Do not use gas-operated cooking and baking facilities for heating purposes.
- ▶ If there are several gas devices, each gas device must have its own gas isolator tap. If individual gas devices are not in use, close the respective gas isolator tap.
- ▶ Ignition safety valves must close within 1 minute after the gas flame has extinguished. A clicking sound is audible. Check function from time to time.
- ▶ The built-in gas devices are exclusively meant for use with propane or butane gas or a mixture of both. The gas pressure regulator as well as all built-in gas devices are designed for a gas pressure of 30 mbar.
- ▶ Propane gas is capable of gasification up to -42 °C, whereas butane gas gasifies at 0 °C. Below these temperatures no gas pressure is available. Butane gas is unsuitable for use in winter.



- ▶ Due to its function and construction, the gas bottle compartment is a space which is open to the exterior. Never cover or block up the standard forced ventilations. Otherwise gas that is emitted can not be diverted to the outside.
- ▶ The gas bottle compartment must not be used as storage space.
- ▶ Secure the gas bottle compartment against unauthorised access. To do this, lock the compartment.
- ▶ The regulator tap on the gas bottle must be accessible.
- ▶ Only connect gas-operated devices (e.g. gas grill) which have been designed for a gas pressure of 30 mbar.
- ▶ The exhaust gas pipe must be fitted tightly to the heating system and to the vent and must be sealed. The exhaust gas pipe must not show any evidence of damage.
- ▶ Exhaust fumes must be able to escape into the atmosphere unhindered and fresh air must be able to enter unhindered. For this reason, keep the exhaust pipe and intake openings clean and unobstructed (e.g. free from snow and ice). For this reason, no snow walls or aprons may lie against the vehicle.

### 2.5.2 Gas bottles



- ▶ Handle full or emptied gas bottles outside the vehicle only with closed regulator tap and attached protective cap.
- ▶ Gas bottles are only to be transported within the designated gas bottle compartment.
- ▶ Place the gas bottles in vertical position in the gas bottle compartment.
- ▶ Fasten the gas bottles so that they are unable to turn or tilt.
- ▶ Connect the gas tube to the gas bottle without tension.
- ▶ If the gas bottles are not connected to the gas tube, always place the protective cap on top.
- ▶ Close the regulator tap on the gas bottle before the gas pressure regulator or gas tube are removed from the gas bottle.
- ▶ Depending on the connection, unscrew the gas tube from the gas bottle and screw it on the gas bottle again by hand or using an suitable special spanner. The screw connection on the gas bottle generally has a left-hand thread. **Do not** tighten too firmly.
- ▶ Only use special gas pressure regulators with a safety valve designed for vehicle use. Other gas pressure regulators are not permitted and cannot meet the demanding requirements.
- ▶ Use the gas pressure regulator defroster if the temperature falls below 5 °C.
- ▶ The designated gas bottle compartment will accommodate two gas bottles, i. e. Calor Gas Butane/Propane or Camping Gaz. All gas bottles **must** be fitted with the appropriate regulator.
- ▶ Use the shortest possible tube lengths (150 cm max.) for external gas bottles.
- ▶ Never block the floor ventilation openings below the gas bottles.

### 2.6 Electrical system



- ▶ Only allow qualified personnel to work on the electrical system.
- ▶ Prior to carrying out work on the electrical system, switch off all devices and lights, disconnect the battery and disconnect the vehicle from the mains.
- ▶ Only use original fuses with the stipulated values.
- ▶ Only replace defective fuses when the cause of the defect is known and has been remedied.
- ▶ Never bridge or repair fuses.

### 2.7 Water system



- ▶ Water left standing in the water tank or in the water pipes becomes undrinkable after a short period. Therefore, before each use of the vehicle, thoroughly clean the water pipes and the water tank. After each use of the vehicle completely empty the water tank and the water pipes.
- ▶ In the case of lay-ups lasting more than a week disinfect the water system before using the vehicle (see chapter 11).



- ▷ If the vehicle is not used for several days or if it is not heated when there is a risk of frost, empty the entire water system. Make sure that the 12 V power supply on the panel is switched off. Otherwise, the water pump will overheat and may get damaged. Leave the water taps on in central position. Leave all drain cocks open. Frost damage to appliances, frost damage to the vehicle and deposits in water-carrying components can be avoided in this way.

## Chapter overview

This chapter contains important information which has to be noted before commencing your journey or carrying out any tasks before the journey.

At the end of the chapter there is a checklist which once again summarises the most important points.

### 3.1 Start-up



- ▷ During the initial journey and each time after changing a wheel, re-tighten the wheel bolts/wheel nuts after 50 km (30 miles). Subsequently inspect them at regular intervals in order to ensure that they are firmly seated.

The motorhome is supplied with a set of keys, consisting of keys for the base vehicle and keys for the body.

Always deposit a replacement key outside the vehicle. Make a note of the key number. Our authorised dealers and workshops can offer assistance in case of loss.

Further information in chapter 12.

### 3.2 Payload



- ▶ Overloading the vehicle and wrong tyre pressure can cause tyres to burst. You can lose control of the vehicle (see section 13.6).
- ▶ The maximum permissible gross weight and the weight including special equipment fitted at the factory (actual weight) is shown in the vehicle documents, but not the weight of the loaded vehicle (see section 3.2.1). For your own safety, we recommend that you have your loaded vehicle (with all passengers, luggage and personal objects) weighed on a public weighbridge before you set out on your journey.
- ▶ Adapt the speed to the payload. The stopping distance is increased if the payload is high.



- ▷ Do not exceed the maximum permissible gross weight (permissible total weight) stated in the vehicle documents and the maximum axle loads as a result of the payload.
- ▷ Built-in accessories and special equipment reduce the payload.

On loading, make sure that the payload's centre of gravity is as low as possible (directly above the floor of the vehicle). Otherwise this may affect the driving characteristics of the vehicle.

**3.2.1 Terms**



▷ Technically speaking, the term "mass" has now replaced the term "weight". However, "weight" is still the term more frequent in common use. For better understanding, "mass" is therefore only used in the following sections for fixed formulations.

**Maximum permissible gross weight in a laden condition**

The maximum permissible gross weight in a laden condition is the weight that a vehicle may never exceed.

The maximum permissible gross weight in a laden condition consists of the **actual weight** and the **payload**.

In the vehicle documents, the manufacturer has specified the maximum permissible gross weight in a laden condition.

**Actual weight**

The actual weight consists of the mass in ready-to-drive condition and the weight of the special equipment fitted at the factory.

**Mass in ready-to-drive condition**

The mass in ready-to-drive condition is the weight of the ready-to-drive standard vehicle (excluding special equipment fitted at the factory).

The mass in ready-to-drive condition is made up as follows:

- Unladen weight (mass of the empty vehicle) with factory-installed standard equipment (excluding special equipment fitted at the factory)
- Driver's weight
- Basic equipment weight

Unladen weight includes lubricants such as oils and coolants which have been filled, the on-board tool set and a fuel tank which has been filled up to 90 %.

75 kg are calculated for the weight of the driver, regardless of how much the driver really weighs.

Basic equipment includes all equipment and fluids required for safe and proper vehicle use. The weight of the basic equipment includes:

- A full fresh water system
- A gas bottle filled up to 90 %
- A full heating system
- The power cables for the 240 V power supply
- A full toilet flushing system
- The installation kit for an auxiliary battery if an auxiliary battery can be used

The waste water and sewage tanks are empty.

**Example for calculating the basic equipment**

Water tank with 100 l	100 kg
Gas bottle (10 kg <sub>gas</sub> + 14 kg <sub>bottle</sub> )	+ 24 kg
Boiler with 12 l	+ 12 kg
240 V power cable	+ 4 kg
Installation kit for auxiliary battery	+ 20 kg
<b>Total</b>	<b>= 160 kg</b>

The weight in ready-to-drive condition and the actual weight are shown by the manufacturer in the vehicle documents.

**Payload** The payload is made up as follows:

- Conventional load
- Additional equipment
- Personal equipment



- ▷ The vehicle's payload can be increased by reducing the actual weight. To do this, it is allowed for example to empty the fluid containers or to remove the gas bottles.

You will find explanations on the individual components of the payload in the following text.

### **Conventional load**

The conventional load is the weight specified by the manufacturer for the passengers.

Conventional load means: 75 kg are calculated for every seat specified by the manufacturer, regardless of how much the passengers actually weigh. The driver's seat is already included as part of the mass in ready-to-drive condition and must **not** be calculated as part of the conventional load.

In the vehicle documents, the manufacturer specifies the number of seats.

### **Additional equipment**

Additional equipment includes accessories and special equipment. Examples of additional equipment include:

- Caravan coupling
- Roof rail
- Awning
- Bike or motorcycle rack
- Satellite unit
- Microwave oven

Chapter 15 lists the weights of the various items of special equipment; they may also be obtained from the manufacturer.

### **Personal equipment**

Personal equipment includes all items in the vehicle that are not included in the conventional load or in the additional equipment. For example, personal equipment can include the following:

- Foodstuffs
- Crockery
- Television
- Radio
- Clothes
- Bedding
- Toys
- Books
- Toiletries

No matter where kept, personal equipment also includes:

- Animals
- Bikes
- Boats
- Surfboards
- Sports equipment

For the personal equipment, according to the applicable regulations, the manufacturer must use a minimum weight that is determined according to the following formula:

**Formula** Minimum weight M (kg) = 10 x N + 10 x L

**Explanation** N = maximum number of people including the driver, as stated by the manufacturer  
L = total length of the vehicle in metres

### 3.2.2 Calculating the payload



- ▶ The payload calculation at the factory is partly based on all-inclusive weights. For safety reasons, the maximum permissible gross weight in a laden condition must not be exceeded.
- ▶ The maximum permissible gross weight and the weight including special equipment fitted at the factory (actual weight) is shown in the vehicle documents, but not the weight of the loaded vehicle (see section 3.2.1). For your own safety, we recommend that you have your loaded vehicle (with all passengers, luggage and personal objects) weighed on a public weighbridge before you set out on your journey.

The payload (see section 3.2.1) is the difference in weight between

- the maximum permissible gross weight in a laden condition and
- the actual weight.

#### Example for calculating the payload

	Mass in kg to be calculated	Calculation
Maximum permissible gross weight according to vehicle documents	3500	
Actual weight including basic equipment according to vehicle documents	- 3070	
<b>This results in a permissible payload of</b>	<b>430</b>	
Conventional load e.g.: 3 persons each weighing 75 kg	- 225	
Additional equipment	- 40	
<b>For the personal equipment this results in</b>	<b>= 165</b>	

The calculation of the payload from the difference between the maximum permissible gross weight in laden condition and the actual weight specified by the manufacturer is however only a theoretical value.

Only if the vehicle is weighed with full tanks (fuel and water), full gas bottles and complete additional equipment on a public weighbridge, can the actual payload be determined.

To do this, proceed as follows:

- First only drive the vehicle on to the weighbridge with the front wheels and have it weighed.
- Then drive the vehicle on to the weighbridge with the back wheels and have it weighed.



The individual values give the current axle loads. These are important for the correct loading of the vehicle (see section 3.2.3). The sum of these values is the current weight of the vehicle.

The actual payload is the difference between the maximum permissible gross weight in laden condition and the weighed vehicle weight.

This can be used to determine the weight that remains for the personal equipment:

- Determine the weight of the passengers and subtract it from the value for the actual payload.

The result is the weight that is permitted for the actual load of the personal equipment.

### 3.2.3 Loading the vehicle correctly



- ▶ For safety reasons, never exceed the maximum permissible gross weight in a laden condition.
- ▶ Distribute the load evenly on the left and right sides of the vehicle.
- ▶ Distribute the load evenly on both axles. In doing so, observe the axle loads specified in the vehicle documents. Observe the permissible load-carrying capacity of the tyres (see chapter 13).
- ▶ Heavy loads behind the rear axle can reduce the load on the front axle due to the leverage effect ( $\frac{1}{2} \rightarrow \frac{1}{4}$ ). This applies especially to long rear extensions or if there is a heavy load in the rear storage space. The release of the front axle negatively affects the driving quality, especially for front-driven vehicles.
- ▶ Store all objects in such a way that they cannot slip.
- ▶ Store heavy objects (awning, tin cans, etc.) close to the axles. Low-lying storage spaces whose doors do not open in the direction of travel are particularly suited for storing heavy objects.
- ▶ Stack light objects (laundry) in the roof storage cabinets.
- ▶ Load the bike rack with bicycles only.
- ▶ Always secure loads onto the clamping eyelets. Always use tightening straps or lashing nets for securing the load, never rubber expanders.



- ▷ Only load the drawers with a maximum of 15 kg.

Large storage spaces, such as the rear storage space, also have room for heavy objects. This might mean that the axle load on the rear axle is exceeded.

However, the individual axles may not be overloaded under any circumstances. That is why it is important, at which distance to the axles the load is stored.

To distribute the load correctly, you will need a scale, a tape measure, a calculator and some time.

Two simple formulas are needed to calculate the effect of the weight of the load on the axles:

**Formulas**  $A \times G : R = \text{weight on the rear axle}$

Weight on the rear axle – G = weight on the front axle

**Explanation**

A = distance between storage space and front axle in cm

G = weight of the load in the storage space in kg

R = wheelbase of the vehicle (distance between axles) in cm



▷ Measure the external distances horizontally from the centre of the front wheel to the centre of the storage space or to the centre of the back wheel.

*Calculating axle loads:*

- Multiply the distance between storage space and front axle (A) with the weight of the load in the storage space (G) and divide the result by the wheelbase (R). The result is the weight of the load in the storage space on the rear axle. Make a note of this weight and of the storage space.
- In a second step, subtract the weight in the storage space (G) from the weight calculated beforehand. If the result is a **positive** value (example 1), this means that the load on the front axle is **reduced** by this value. If the result is a **negative** value (example 2), this means that the load on the front axle is **increased**. Make a note of this value, too.
- Calculate all storage spaces of the vehicle in the same way.
- In a last step, add all weights calculated for the rear axle to the rear axle load and add (or subtract) all weights calculated for the front axle to (from) the front axle load.  
How to determine rear axle load and front axle load is described in section 3.2.2.

If the calculated value exceeds the permissible axle load, the load must be distributed in a different way.

If the load on the front axle is too low, the grip of the tyres on the road is reduced (traction). This applies in particular to vehicles with front-wheel drive. In this case, the load must be redistributed, too.

**Example calculation**

		<b>Example 1</b>	<b>Example 2</b>
Distance to the front axle	A	(A1) 450 (cm)	(A2) 250 (cm)
Weight in the storage space	G	x 100 (kg)	x 50 (kg)
Wheelbase of the vehicle	R	÷ 325 (cm)	÷ 325 (cm)
<b>Load on the rear axle (add to the axle load)</b>		<b>138.5 (kg)</b>	<b>38.5 (kg)</b>
Weight in the storage space		- 100 (kg)	- 50 (kg)
<b>Load relief to the front axle (subtract from the axle load)</b>		<b>38.5 (kg)</b>	
<b>Load on the front axle (add to the axle load)</b>			<b>-11.5 (kg)</b>

### 3.2.4 Bike rack



- ▶ On model Serengeti it is not allowed to mount a bike rack.
- ▶ Observe the permissible axle loads and maximum permissible gross weight when loading the bike rack.
- ▶ A total width of 2.55 m must not be exceeded. Adjust the attachments for the bikes accordingly. The overhang to the side and rear must be marked in accordance with the regulations for the country in which you are travelling.
- ▶ Load the bike rack with bicycles only.
- ▶ Do not transport more than the permitted number of bicycles for the bike rack used (max. 50 kg).
- ▶ Check the secure attachment of the bicycles on the bike rack after the first 10 km and then at each break in the journey.
- ▶ Do not use the bike rack as luggage rack or ladder.



- ▷ The identification plate and rear lights must not be covered.
- ▷ Driving with a folded out bike rack without bicycles is not permitted.
- ▷ Before every journey, check:
  - Is the bike rack without bicycles folded in correctly?
  - Are the bicycles securely fastened to the bike rack using the bike rack belts?

#### Loading the bike rack with bicycles

When loading the bike rack, observe the centre of gravity. The centre of gravity of the bicycles must be as close as possible to the rear wall of the vehicle. The bike rack should always be loaded from the inside to the outside.

Loading the bike rack correctly:

- Fold the bike rack downwards.
- Place the heaviest bicycle directly against the rear wall.
- Place the lightest bicycles in the centre or on the outside of the bike rack.
- Secure the front and rear wheels of each bicycle with the retaining straps on the bike rack.
- In addition, fasten the outermost bicycle on the retaining bracket or retaining arm.

If the bike rack is only loaded with **one** bicycle, position the bicycle as closely as possible to the rear wall.

#### 3.2.5 Roof load



- ▶ Do not overload the roof. Road behaviour and brake reaction deteriorate as the roof load increases.



- ▷ The maximum permitted roof load is 50 kg.
- ▷ Secure roof loads with tension belts. Do not use rubber expanders.
- ▷ Observe the overall height of the vehicle when the roof rack is loaded.



- ▷ The driver's cabin should have a clearly visible notice stating the overall height. This eliminates the need for calculations at bridges and thoroughfares.



Fig. 1 Elevating roof with roof rack

#### 3.3 Towing



- ▶ Care is to be taken when connecting and detaching a trailer. Risk of accident and injury!
- ▶ No persons are to be between the motorhome and the trailer during positioning for connecting and detaching.
- ▶ Observe the permissible nose weight and rear axle load of the motorhome. Nose weight and rear axle load must not be exceeded. The values of the nose weight and rear axle load are included in the documents of the vehicle and the caravan coupling.



- ▷ Trailer with an overrun brake: Do not connect or detach trailer with the overrun brake on.
- ▷ Caravan coupling with detachable ball neck: If the ball neck is mounted incorrectly, there is the danger of the trailer breaking away. Observe the instruction manual for the caravan coupling.



- ▷ Fiat base vehicle: Depending on the model, the maximum permissible nose weight is 80 kg to 120 kg.  
Mercedes-Benz base vehicle: Depending on the model, the maximum permissible nose weight is 100 kg to 140 kg.  
Please refer to the EEC certificate of conformity for the applicable data. The EEC declaration of conformity is handed over to every owner.

### 3.4 Caravan coupling



- ▶ When mounting a caravan coupling, see the vehicle documents for information on maximum nose weight and caravan load.
- ▶ Retighten the caravan coupling fixing screws after 1000 operating hours.



- ▷ The bike rack and caravan coupling may not be used simultaneously.



- ▷ If the caravan coupling was fitted at the factory, this is entered in the vehicle documents. Always keep the appropriate documents in the vehicle.
- ▷ Also read the manufacturer's instruction manual.



Fig. 2 Caravan coupling (detachable)

#### Entry in the vehicle documents

Have your dealer or service centre install the add-on parts. They will also take care of all the formalities for you.

### 3.5 Electrically operated entrance step



- ▶ Before commencing the journey and after short interruptions of the journey, ensure that the entrance step is completely retracted.
- ▶ Do not stand in the direct range of the entrance step while it is being retracted or extended.
- ▶ Do not step on the entrance step until it has extended completely. There is a risk of injury.
- ▶ To prevent danger of slipping, clean the entrance step if necessary before entering (snow, ice, mud, etc.).
- ▶ Do not under any circumstances raise or lower persons or loads with the entrance step.
- ▶ Following a cold start, for vehicle-related reasons it can take a few seconds before the warning tone sounds.



- ▷ Do not grease or lubricate the pivot bearing and joints of the entrance step (see chapter 11).



- ▷ The button to operate the entrance step is located on the inside of the vehicle in the area of the conversion door.

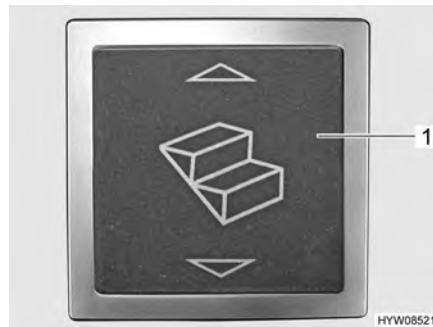

Fig. 3 Rocker button for entrance step (entrance area)

*Retracting or extending:*

- Press the rocker button (Fig. 3,1) situated in the entrance area.

When the engine is running and the entrance step is extended, a warning tone is heard. The warning tone ceases as soon as the entrance step is retracted.

#### 3.6 Television



- ▶ Before commencing the journey, store the television securely.

#### 3.7 Kitchen area



- ▶ In the event of an accident or heavy braking, flying objects could injure the occupants of the vehicle. Before moving off, secure all moveable objects and remove all loose objects and store them securely.

#### 3.8 Gas regulator



- ▶ Operating gas-operated appliances during the journey is permitted only if the gas system has the relevant equipment. The hose break guard and crash sensor prevent an escape of gas in the event of an accident.

Depending on the equipment, different gas regulators can be installed in the vehicle.

If a gas regulator other than one of those listed below is installed in the vehicle, the regulator tap on the gas bottle and the gas isolator taps must be closed during the journey.

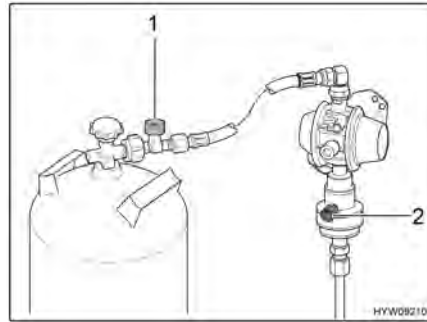

Fig. 4 Gas regulator (MonoControl)

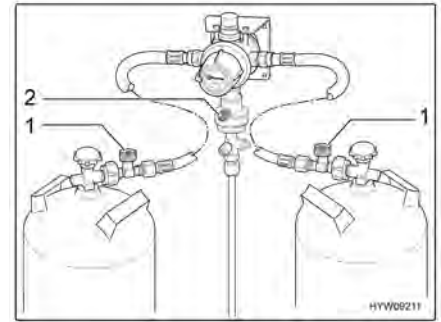

Fig. 5 Gas regulator (DuoControl)

**Gas regulator with crash sensor and hose break guard**

If a gas regulator with a crash sensor (Fig. 4,2 and Fig. 5,2) and hose break guard (Fig. 4,1 and Fig. 5,1) is installed in the vehicle:

The regulator tap on the gas bottle and the "Heater" gas isolator tap may remain open during the journey. Gas-operated appliances may be on during the journey.

The design details of the MonoControl (Fig. 4) and DuoControl (Fig. 5) gas regulators can vary (straight or angled).



- ▷ If in doubt, get the relevant information from authorised dealers or service centres.

**3.9 Snow chains**



- ▷ Only mount snow chains if there is a clearance of at least 50 mm between the tyres and the vehicle body.
- ▷ When using snow chains, the tyres, wheel suspension and steering are subjected to an additional load. When using snow chains, drive slowly (maximum speed 50 km/h) and only on streets which are completely covered with snow. Otherwise the vehicle could be damaged.
- ▷ Observe the fitting instructions issued by the manufacturer of the snow chains.
- ▷ Do not fit snow chains on alloy wheel rims.

The use of snow chains is subject to the legal regulations of the individual countries.

- Always mount snow chains to the drive wheels.
- After a few metres, check the tension of the snow chains.

**3.10 Road safety**



► Check tyre pressure before a journey or every 2 weeks. Wrong tyre pressure causes excessive wear and can lead to damage or even to tyre burst. You can lose control of the vehicle (see section 13.6).

Before commencing the journey, work through the checklist:

	No.	Checks	Checked
<b>Base vehicle</b>	1	All vehicle documents are on board	
	2	Tyres in proper condition and tyre pressure correct	
	3	Vehicle lighting, brake lights and reversing lights function	
	4	Oil levels for engine, gearbox and power steering controlled	
	5	Coolant and fluid for windscreen washers filled up	
	6	Brakes function	
	7	Brakes react evenly	
	8	When braking, the vehicle remains in the lane	
<b>Housing body, outside</b>	9	Awning completely retracted	
	10	Elevating roof closed and locked	
	11	Roof free of snow and ice (in winter)	
	12	External connections and lines disconnected and stored away	
	13	External supports removed	
	14	Entrance step retracted (observe warning tone)	
	15	Rear doors closed	
	16	Overall height of the vehicle including roof rack when loaded measured and noted. Keep the height information close at hand in the driver's cabin	
<b>Housing body, inside</b>	17	Windows, skylights and elevating roof closed and locked	
	18	Television secured	
	19	Television antenna retracted (if one is built in)	
	20	Loose parts stored away or fixed in position	
	21	Open storage spaces empty	
	22	Refrigerator door secured	
	23	All drawers and flaps closed	
	24	Children's seats only mounted on the seats approved for this purpose	
	25	Swivel seat locking device for driver's seat and front passenger's seat locked	
	26	Shades in the driver's cabin opened and secured	



**Gas system**

No.	Checks	Checked
27	Gas bottles firmly fixed in the gas bottle compartment so that they are unable to turn	
28	If the gas bottles are not connected to the gas tube, always place the protective cap on top	
29	Regulator tap on the gas bottle and gas isolator taps are closed   ▷ When there is a MonoControl / DuoControl regulating system: When heating is required during travel the gas isolator tap "Heater" and the regulator tap can remain open.	

**Electrical system**

30	Check the battery voltage of the starter and living area battery (see chapter 8). If the panel indicates that the battery voltage is too low, the respective battery will need to be recharged. Observe the notes and instructions in chapter 8   ▷ Commence journey with fully charged starter and living area batteries.	
----	---	--



## Chapter overview

This chapter contains instructions on how to drive the motorhome.

### 4.1 Driving the motorhome



- ▶ The base vehicle is a commercial vehicle (small truck). Adjust your driving technique accordingly.
- ▶ Before commencing the journey and after short interruptions of the journey, ensure that the entrance step is completely retracted.
- ▶ When you start the engine, warning signals such as "entrance step extended" can sound. Under certain conditions (a cold start in winter) after the engine is started it can take up to 15 seconds for these warning signals to sound.
- ▶ A seat belt is fitted for each seat which is permitted for travel. Please keep your seat belt fastened during the journey.
- ▶ Never open your seat belts when travelling.
- ▶ Passengers must remain in the seats provided.
- ▶ The doors must remain locked.
- ▶ Avoid braking with a jerk.
- ▶ If a navigation system is used, only change the destination when the vehicle is stationary. Drive to a car park or stop in a safe area when changing the destination.
- ▶ Do not play DVDs using the monitor of the navigation system during the journey.



- ▷ Drive slowly on poor roads.



- ▷ If an accident occurs as a result of these instructions not being observed, the manufacturer will not be responsible for damages caused.
- ▷ The safety measures stipulated in chapter 2 have to be observed.

### 4.2 Driving speed



- ▶ The vehicle is equipped with a powerful engine. This means there are sufficient reserves in difficult traffic situations. This high power enables a high maximum speed and requires above-average driving ability.
- ▶ The vehicle provides a large contact surface for wind. A sudden crosswind can be especially dangerous.
- ▶ Uneven or one-sided loading affects road performance.
- ▶ Driving on unknown streets, you may encounter hazardous road conditions and unexpected driving situations. Therefore, in the interest of safety, make sure your driving speed is appropriate to any given driving situation and environment.
- ▶ Adhere to the national legal speed limits.

### 4.3 Brakes



- ▶ Have defects on the braking system immediately remedied by an authorised specialist workshop.

#### Before each journey

Before each journey, check by means of a braking test:

- Do the brakes function?
- Do the brakes react evenly?
- Does the vehicle remain in the lane when braking?

### 4.4 Seat belts

#### 4.4.1 General

The vehicle is equipped with seat belts in the living area on the seats for which seat belts are compulsory by law. National regulations apply seat-belt fastening.



- ▶ Fasten your seat belts before the beginning of the journey and keep them fastened during the journey.
- ▶ Do not damage or trap belts. Have damaged seat belts changed by an authorised specialist workshop.
- ▶ Do not alter the belt fixing devices, automatic seat belt winders and the belt clips.
- ▶ Only use one seat belt for **one** adult person.
- ▶ Do not belt in objects together with persons.
- ▶ Seat belts are not sufficient for persons who are less than 150 cm tall. In these cases use additional restraining devices. Observe test certificate.
- ▶ Only attach the child restraint system to seats that are specified for this purpose.
- ▶ After an accident, replace the seat belts.
- ▶ During the journey, do not tilt the backrest too far backwards. Otherwise the functionality of the seat belt is no longer guaranteed.

#### 4.4.2 Fastening the seat belt correctly



- ▶ Do not twist the belt. The belt must be positioned smoothly against the body.
- ▶ When fastening the seat belt, adopt the correct sitting position.

The seat belt is correctly fastened when the lap belt passes below your stomach and across the hip bone. The shoulder belt must pass across the chest and shoulder (not across your neck). The belt must always be taut against your body. Any bulky or padded clothing should therefore be removed before you start your journey.

### 4.5 Child restraint systems



- ▶ When travelling, secure children under 13 years of age that are smaller than 150 cm, with a suitable and officially approved child restraint system.
- ▶ Only attach the child restraint system to seats that are specified for this purpose.
- ▶ Fasten the childrens' seat belts before commencing the journey and make sure that their seat belts are kept fastened during the journey.
- ▶ If a front passenger airbag is fitted in the vehicle, do not use a child restraint system (Reboard systems) that faces the back of the front passenger's seat. Follow warning notices in the vehicle.
- ▶ If it is necessary to let an infant travel in a cradle in the opposite direction to travel on the front passenger's seat, the airbags on the passenger side must be deactivated via the setup menu of the base vehicle. When the airbags are deactivated, an indicator lamp must be lit on the instrument panel (refer to the operating manual of the base vehicle). Before setting off, verify whether the indicator lamp is lit. Push the front passenger's seat backwards as far as it will go such that the child seat does not touch the dashboard.

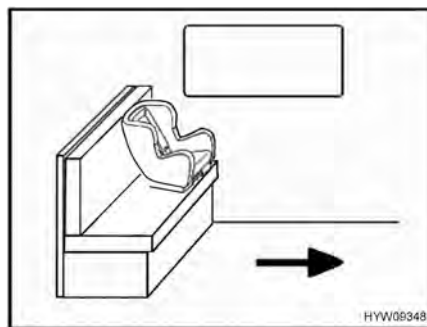

Fig. 6 Child seat on bench

Only one child seat is allowed next to the window on the bench (Fig. 6). The back cushion on the side wall must be removed when a child seat is fitted. Fold the suspension table away downwards.

Child restraint systems are divided into five classes:

Class	Body weight	Approximate age
0	Up to 10 kg	Up to 9 months
0+	Up to 13 kg	Up to 18 months
I	9 kg to 18 kg	9 months to 4 years
II	15 kg to 25 kg	3 years to 7 ½ years
III	22 kg to 36 kg	6 years to 12 years

The following table shows which restraint systems can be used on which seats.

Seats	Age groups				
	< 10 kg (0-9 months)	< 13 kg (0-24 months)	9-18 kg (9-48 months)	15-36 kg (4-12 years)	
All models built on Fiat chassis	Front passenger's seat	U <sup>1)</sup>	U <sup>1)</sup>	UF	UF
	Second row of seats	U	U	U	U

All models built on Mercedes-Benz chassis

Front passenger's seat	X	X	UF	UF
Second row of seats	U <sup>2)</sup>	U <sup>2)</sup>	UF	UF

### Meaning of letters:

U: Suitable for "universal" restraint systems which are authorised for this age group.

UF: Suitable for forward-facing "universal" restraint systems which are authorised for this age group.

X: Seat is not suitable for children in this age group.

U<sup>1)</sup>: Only when front passenger's airbag is deactivated.

U<sup>2)</sup>: Only seat next to the window.

### 4.6 Driver's seat and front passenger's seat



- ▶ Before commencing the journey, rotate all swivel seats in the direction of travel and lock in position.
- ▶ The seats must remain fixed in position during the journey and are not to be rotated.



- ▷ Mercedes-Benz base vehicle: If the driver's and front passenger's seats have been rotated towards the door to facilitate getting on and off, return the respective seat to its original position before closing the door. For the change between driving position and living position, rotate the driver's and front passenger's seats only inwards. The map pocket on the inside of the doors could otherwise get damaged.



- ▷ The driver's and front passenger's seat are a part of the base vehicle, depending on model and vehicle equipment. In this case the adjustment of the seats is described in the operating instructions of the base vehicle.



Fig. 7 Operating controls on seat (Fiat as example)

**Rotating seat into driving position**

During the journey, the driver's and front passenger's seats must be rotated in the direction of travel and locked in position.

- Push both armrests upward.
  - Push the seat backwards or into the central position.
  - Rotate the seat inwards, into the direction of travel and lock in position.
- ▷ Rotating the seats in the pitched vehicle is described in chapter 6.



**Adjusting seat in lengthways direction**

Adjust the driver's seat so that the driver can depress the pedals comfortably.

- Pull the bar (Fig. 7,2) upwards.
- Push the seat forwards or backwards.
- Release the bar. The seat must audibly lock into place.

**Setting the seat inclination**

Adjust the seat inclination so that the thighs rest on the seat surface without any pressure.

- Pull the handle (Fig. 7,3) upwards.
- Bring the front seat into the desired inclination position by applying or relieving pressure.
- Release handle. The seat must audibly lock into place.
- Pull the handle (Fig. 7,4) upwards.
- Bring the rear seat into the desired inclination position by applying or relieving pressure.
- Release handle. The seat must audibly lock into place.

**Adjusting the backrest**

Adjust the angle of the backrest of the driver's seat so that the steering wheel can be held with the arms slightly bent.

- Turn the knurled knob (Fig. 7,5). The backrest inclines forwards or backwards, depending on the rotation direction.

**Adjusting the armrest**

The height of the armrests can be steplessly adjusted.

- Turn the knurled wheel (Fig. 7,1). The armrest inclines upwards or downwards, depending on the rotation direction.

### 4.7 Headrests



Fig. 8 Headrest (bench)

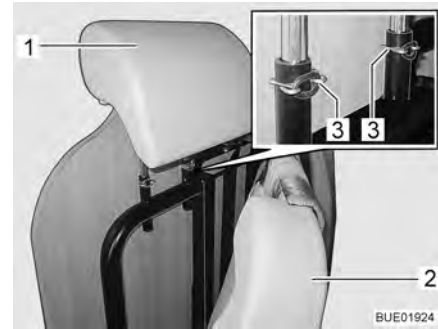

Fig. 9 Adjusting the headrest

Before commencing the journey, adjust the headrest (Fig. 9,1) so that the back of the head is supported at approximately ear height.

*Adjusting the headrest:*

- Fold the cushion (Fig. 9,2) forwards.
- Remove the safety clamps (Fig. 9,3).
- Pull the headrest (Fig. 9,1) upward or push it downward until it reaches the desired locking position.
- Fit the safety clamps.
- Fold back the cushion.

### 4.8 Seating arrangement



- ▶ During the journey, persons are only to sit on the permitted seats. The authorised number of seats is stipulated in the vehicle documents.
- ▶ During the journey sitting on the divans is not permitted.
- ▶ Seat belts must be worn by all passengers.

Seats which may be used during travel are equipped with a seat belt.

### 4.9 Roman shades for driver's window and front passenger's window



- ▶ While travelling, the Roman shades for the driver's window and front passenger's window must be open, in a fixed position and secured.

*Securing:*

- Carefully push back the Roman shades for the side panes.
- Secure Roman shades.



#### 4.10 External doors



- ▶ Only drive with locked external doors.



- ▷ Locking the doors can prevent them from opening of their own accord, e.g. during an accident.
- ▷ Locked doors also prevent forced entry, e.g. when waiting at traffic lights. However, in an emergency, locked doors make it more difficult for helpers to enter the vehicle.
- ▷ When leaving the vehicle, always lock the doors.
- ▷ The doors are part of the base vehicle. The opening and closing of the doors is described in the instruction manual of the base vehicle.

#### 4.11 Refuelling



- ▶ All gas-operated devices must be switched off for refuelling (heater, cooker, oven, grill, refrigerator - depending on the equipment). Danger of explosion!



- ▷ The fuel filler neck is part of the base vehicle.
- ▷ The fuel filler neck is labelled with the word "Diesel".



Fig. 10 Warning notice (fuel filler neck)

Refer to the instruction manual for the base vehicle for the position of the fuel filler neck.

### 4.12 Towing



- ▶ If the ignition key cannot be turned in the ignition lock, do not tow the vehicle. The steering will be locked.



- ▷ If the engine is not running or the power supply is disrupted, the servo assistance for the steering and brakes will not be operational. A considerable amount of force will be required for steering and braking.

If the vehicle has to be towed, it should be done on a transporter or trailer if at all possible. If this is not possible, we recommend always using a towing bar for towing. The towing bar must be approved for the weight of the vehicle.



- ▷ In addition observe the notes in the operating manual of the base vehicle.
- ▷ National regulations apply to towing.

## Chapter overview

This chapter contains instructions on how to pitch the vehicle.

### 5.1 Handbrake

Firmly apply the handbrake when parking the vehicle.

### 5.2 Entrance step

In order to exit the vehicle, first fully extend the entrance step. If the entrance step is extended while the engine is still running, a warning tone will sound.

### 5.3 240 V connection

The vehicle can be connected to a 240 V power supply (see chapter 8).

### 5.4 Refrigerator

Connect the vehicle to a 240 V supply (if possible), so that the living area battery is not discharged.

### 5.5 Awning



- ▷ When the support legs are not positioned, extend the awning a maximum of 1 m.
- ▷ Retract the awning in strong wind, rain or snow.
- ▷ In the case of light rain, shorten one of the support legs so that water can run off.
- ▷ In case of light wind or rain, anchor the awning with ropes on both sides.
- ▷ Only retract the awning when the fabric is dry. When the awning must be retracted while the fabric is still wet: Extend the awning as soon as possible, in order to dry out the fabric.
- ▷ Before retracting, remove leaves and coarse dirt from the awning.

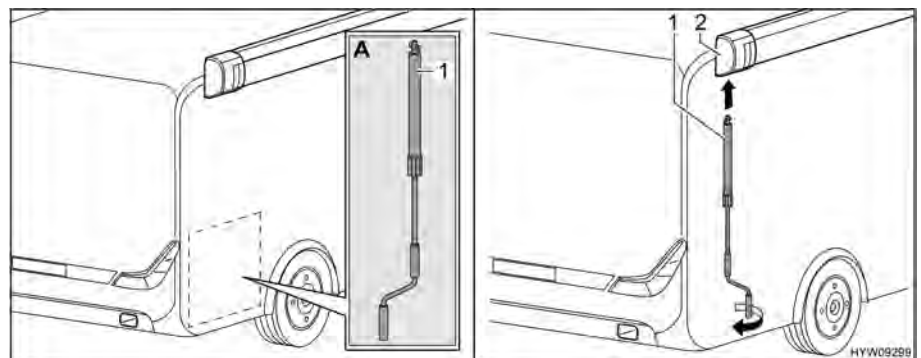

Fig. 11 Installing crank

*Extending the awning:*

- Take crank (Fig. 11,1) out of the rear garage (Fig. 11,A).
- Insert crank into bayonet socket (Fig. 11,2) of the awning.
- Turn the crank in an anticlockwise direction until the awning is extended to a maximum of 1 m.

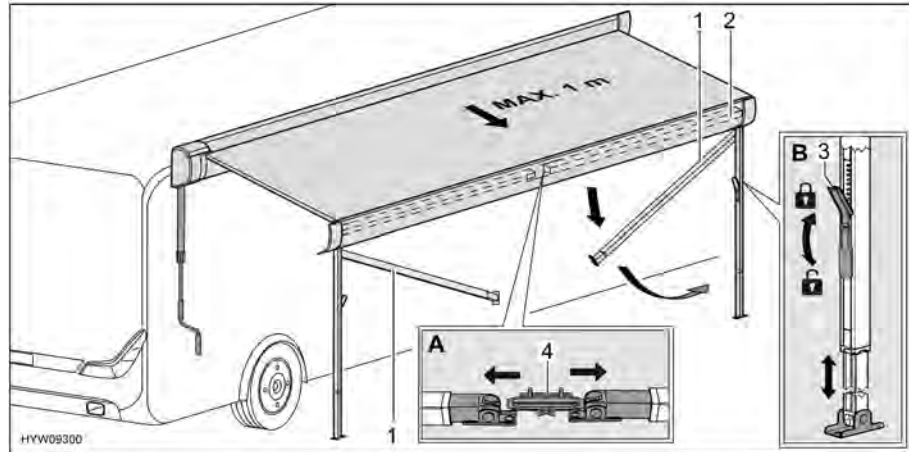

Fig. 12 Preparing support legs

- Release support legs (Fig. 12,1) from holder (Fig. 12,4) in the front bar (Fig. 12,2). In order to do this, apply slight outward pressure on the support legs (Fig. 12,A).
- Fold out the support legs.
- Release the locks (Fig. 12,3) of the support legs. In order to do this, fold the catch lever downwards.
- Pull lower part of the support legs out to the desired length (Fig. 12,B).
- Position the support legs.
- Close the locks (Fig. 12,3) of the support legs. In order to do this, fold the catch lever upwards.

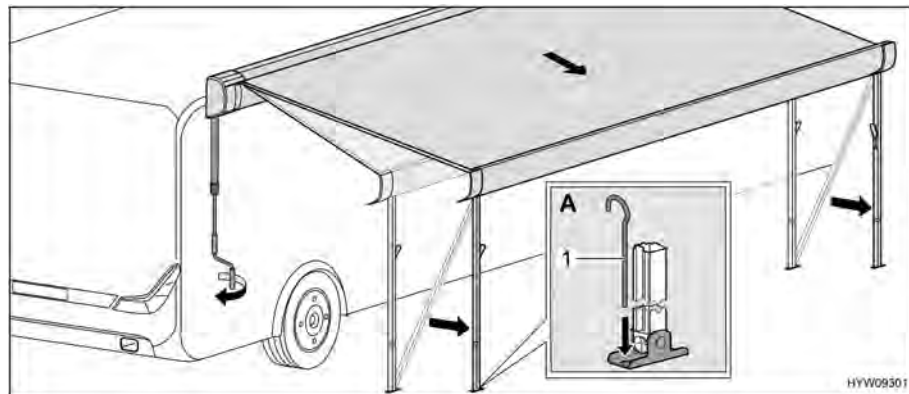

Fig. 13 Bringing awning into end position

- Use the crank to completely extend the awning. While doing so, reposition the support legs several times.
- Set the support legs to their final height.
- Pull crank out and store it in the rear garage.
- Fix the support legs to the floor with tent pegs (Fig. 13,1) (Fig. 13,A).

*Retracting the awning:*

- If present, remove guy ropes and tent pegs.
- Insert the crank in the bayonet socket of the awning and turn in a clockwise direction until the awning has been retracted up to approx. 1 m.
- If necessary, clean the support legs.
- Open the lock on the support legs. In order to do this, fold the catch lever downwards.
- Push the lower part of the support legs in completely.
- Fold both support legs upward into the front bar and let them click into position. In order to do this, apply slight outward pressure on the support legs.
- Continue turning the crank until the awning has been retracted completely.
- Remove the crank from the bayonet socket and store it.



## Chapter overview

This chapter contains instructions about living in the vehicle.

### 6.1 External doors



- ▶ Only drive with locked external doors.



- ▷ Locking the doors can prevent them from opening of their own accord, e.g. during an accident.
- ▷ Locked doors also prevent forced entry, e.g. when waiting at traffic lights. However, in an emergency, locked doors make it more difficult for helpers to enter the vehicle.
- ▷ When leaving the vehicle, always lock the doors.
- ▷ The doors are part of the base vehicle. The opening and closing of the doors is described in the instruction manual of the base vehicle.

### 6.2 External flaps



- ▷ Before commencing the journey, close and lock the external flap.

#### 6.2.1 External flap Thetford cassette

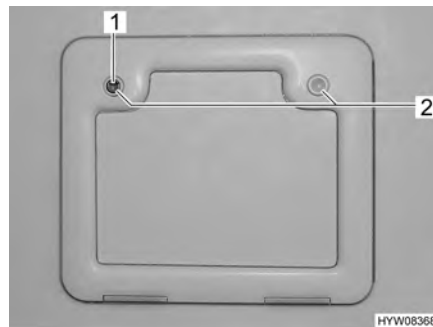

Fig. 14 External flap Thetford cassette

- Opening:*
- Insert key into locking cylinder (Fig. 14,1) of the push-button lock and turn a quarter turn.
  - Remove the key.
  - Press both push-button locks (Fig. 14,2) simultaneously with your thumb and open the external flap.
- Closing:*
- Close the external flap and press it shut.
  - Insert key into locking cylinder (Fig. 14,1) and turn a quarter turn.
  - Remove the key.

### 6.3 Ventilation



- ▶ The oxygen in the vehicle interior is used up by breathing and the use of gas operated appliances. That is why the used air must be replaced permanently. For this purpose, forced ventilation options (e.g. skylights with forced ventilation, mushroom-shaped vents or floor vents) are fitted to the vehicle. Never cover or block forced ventilations from the inside or outside with objects such as e.g. a winter mat. Keep forced ventilations clear of snow and leaves. There is a danger of suffocation due to increased CO<sub>2</sub> levels.



- ▷ Although sufficient ventilation is provided, in certain weather conditions, condensation can form on metal objects (e.g. screwed connections in the floor).
- ▷ Additional cold spots can occur at thermal "bridges" (e.g. mushroom-shaped vents, skylight edges, sockets, filler necks, flaps, etc.).



- ▷ If the vehicle is not to be used for a prolonged period:
  - Air the interior thoroughly every 3 weeks. The elevating roof must be open for this.
  - Remove the mattress from the vehicle and store in a dry place.
  - Set up de-humidifiers (granulate). Follow the manufacturer's instructions.
 If the humidity in the interior is higher for an extended period, mildew and mould can form.

#### Condensation

Ensure that there is a continuous exchange of air by providing frequent and efficient ventilation. This is the only method for ensuring that condensation and resulting mould is not formed during cool weather. During the colder season, a pleasant living climate is created if heating output, air distribution and ventilation are synchronised. To avoid draft close the air outlet nozzles on the dashboard and set the air distribution of the base vehicle to air circulation.

If the vehicle is laid up for a longer period, occasionally ventilate it well, especially in summer as heat accumulation can occur. Do not only air the interior, but also the storage spaces which are accessible from the outside. Air the parking place as well if the vehicle is parked in a closed space (e.g. garage). The occurrence of condensation could lead to the formation of mould.

### 6.4 Windows



- ▷ The windows are fitted with a blind or Roman shade and with an insect screen or folding insect screen. After the latch has been released, the blind and insect screen automatically spring back to the initial position by tensile force. In order not to damage the tension mechanics, hold onto the blind or insect screen and allow it to slowly return to the initial position. The Roman shade and folding insect screen are made of thin woven fabric. In order not to damage the Roman shade or the insect screen, grasp the respective handle and carefully return it to the initial position.
- ▷ Do not keep blinds closed over a longer period of time as that can cause increased material wear.
- ▷ If the blind or the Roman shade is completely closed, exposure to direct sunlight can cause heat to accumulate between the blind/the Roman shade and the glass window. The window could be damaged. For that reason, close the blind/Roman shade only 2/3 of the way in direct sunlight.





- ▷ Before commencing the journey, close the windows.
- ▷ Depending on the weather, close the windows far enough to prevent moisture from entering.



- ▷ When leaving the vehicle, always close the windows.
- ▷ In extreme weather conditions or if the temperature fluctuates strongly, a light condensation film can form on the double-glazed acrylic glass. The glass is designed in such a way that condensation can evaporate when the external temperature increases. There is no danger of the double-glazed acrylic glass being damaged by condensation.
- ▷ The upholstery will fade over time, if it is exposed to sunlight. If the temperature within the vehicle rises rapidly as well, the colour will change at an accelerated rate.  
Therefore, we recommend to close the shades on the windows when there is strong sunlight. Ensure that heat does not build up when you close the blind.

**6.4.1 Hinged window**



- ▷ If windows with automatic hinges are fitted, open the window fully in order to release the lock. If the locking device is not released and the window is closed nevertheless, there is the danger of the window breaking due to the massive counter-pressure.
- ▷ When opening the hinged windows, ensure that there are no torsional forces. Open and close the hinged windows evenly.
- ▷ Depending on the equipment, the vehicle will be equipped with a hinged window (Fig. 15,1) on the rear right side. Close the hinged window before opening the sliding door. Otherwise, the sliding door may hit the hinged window!
- ▷ Before opening or closing the sliding door, close and lock the hinged window (Fig. 15,2) in the sliding door. The window could otherwise get damaged due to the vibration.



Fig. 15 Hinged window (right side)

The hinged windows have to positions: "locked" and "continuous ventilation".



Fig. 16 Catch lever ("closed" position)



Fig. 17 Hinged window with automatic hinge

- Opening:**
- Turn the catch lever (Fig. 16,3) a quarter turn towards the centre of the window.
  - Open hinged window half up to the required position. Allow the hinged window to engage automatically with the automatic hinge (Fig. 17,1).

The hinged window remains locked in the required position.

- Closing:**
- Open the hinged window as wide as necessary until the latch releases.
  - Close the hinged window.
  - Turn the catch lever (Fig. 16,3) a quarter turn towards the window frame. The locking catch (Fig. 16,1) is located on the inside of the window catch (Fig. 16,2).

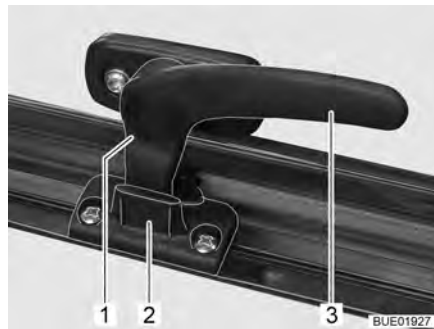

Fig. 18 Catch lever ("continuous ventilation" position)

### Continuous ventilation

With the catch lever, the hinged window can be placed in two positions:

- "Continuous ventilation" (Fig. 18)
- "Firmly closed" (Fig. 16).

To place the hinged window into the "continuous ventilation" position:

- Turn the catch lever (Fig. 18,3) a quarter turn towards the centre of the window.
- Slightly open the hinged window outwards.
- Turn the catch lever a quarter turn towards the window frame. The locking catch (Fig. 18,1) has to be moved into the recess of window catch (Fig. 18,2).

During the journey, the hinged window may not be in "continuous ventilation" position.

If it rains, the "continuous ventilation" hinged window position could lead to splashing water penetrating the living area. Therefore, close the hinged windows completely.

**6.4.2 Roman shade and insect screen**

The windows are fitted with a Roman shade and an insect screen. The Roman shade and insect screen can be adjusted separately or together. If adjusted together, the handles are held together magnetically.



Fig. 19 Roman shade and insect screen

*Opening/closing the Roman shade:*

- Hold the handle (Fig. 19,1) in the centre and pull it up/down carefully. The Roman shade will stay in any desired position.

*Opening/closing the insect screen:*

- Hold the handle (Fig. 19,2) in the centre and pull it up/down carefully. The insect screen will stay in any desired position.

**6.4.3 Roman shades for windscreen, driver's window and front passenger's window**

**Windscreen**

Various locking systems are built in depending on the model.



Fig. 20 Roman shade (windscreen, Fiat)



Fig. 21 Roman shade (windscreen, Mercedes-Benz)

*Closing:*

- Press the locking handles together (Fig. 20,1) and keep them in this position or slide the locking knobs (Fig. 21,1) up or down (red point = open).
- Use the handle (Fig. 20,2 or Fig. 21,2) to pull the Roman shade for the windscreen towards the centre of the window.
- Close the second Roman shade for the windscreen in the same way. A magnetic catch holds both parts of the Roman shade together in the centre.

- Opening:*
- Depending on the locking system, press and hold down the locking handle (Fig. 21,1).
  - Use the handle (Fig. 20,2 or Fig. 21,2) to pull the two halves of the Roman shade for the windscreen outwards as far as they will go.
  - Release the locking handles (Fig. 20,1) and allow them to engage or slide the locking knobs (Fig. 21,1) up or down (no red point = locked).

### Driver's/front passenger's windows

Various locking systems are built in depending on the model.

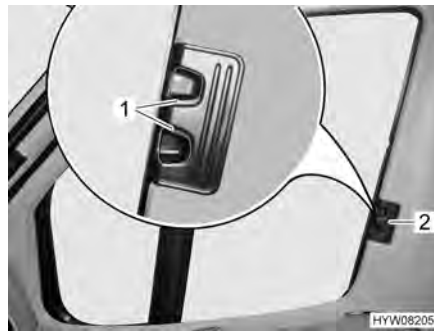

Fig. 22 Roman shade (driver's / front passenger's window, Fiat)

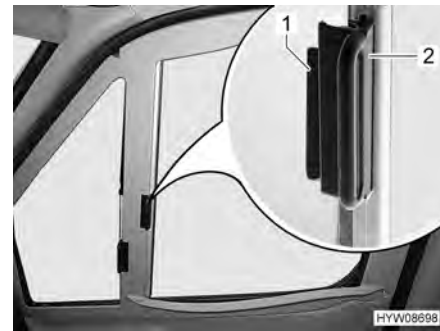

Fig. 23 Roman shade (driver's / front passenger's window, Mercedes-Benz)

- Closing:*
- Depending on the locking system, press and hold down the locking handle (Fig. 22,1).
  - Using the handle (Fig. 22,2 or Fig. 23,2), draw the Roman shades for the driver's and passenger's window to the other side of the window and secure them to the magnetic strips.
- Opening:*
- Depending on the locking system, press and hold down the locking handle (Fig. 22,1).
  - Use handle (Fig. 22,2 or Fig. 23,2) to push in the Roman shades for the driver's and passenger's window as far as possible.
  - Release the locking handle (Fig. 22,1) and let it click into place or push the handle (Fig. 23,2) onto the cap (Fig. 23,1).

## 6.5 Skylights



- ▶ The apertures for forced ventilation must always be kept open. Never cover or block forced ventilations with objects such as e.g. a winter mat. Keep forced ventilations clear of snow and leaves.



- ▷ The skylights are fitted with a blind or Roman shade and with an insect screen or folding insect screen. After the latch has been released, the blind and insect screen automatically spring back to the initial position by tensile force. In order not to damage the tension mechanics, hold onto the blind or insect screen and allow it to slowly return to the initial position. The Roman shade and folding insect screen are made of thin woven fabric. In order not to damage the Roman shade or the insect screen, grasp the respective handle and carefully return it to the initial position.
- ▷ Do not keep blinds closed over a longer period of time as that can cause increased material wear.



- ▷ If the blind or the Roman shade is completely closed, exposure to direct sunlight can cause heat to accumulate between the blind/the Roman shade and the skylight. The skylight could be damaged. For that reason, close the blind/Roman shade only 2/3 of the way in direct sunlight. Open the skylight slightly or move it to ventilation position.
- ▷ Depending on the weather, close the skylights far enough to prevent moisture from entering.
- ▷ Do not climb on the skylights.
- ▷ Before commencing the journey, close the skylights.
- ▷ Before commencing the journey, check that the skylights are closed and locked.
- ▷ Before commencing the journey, open the blinds or Roman shades.



- ▷ When leaving the vehicle, always close the skylights.
- ▷ The upholstery will fade over time, if it is exposed to sunlight. If the temperature within the vehicle rises rapidly as well, the colour will change at an accelerated rate.  
Therefore, we recommend closing the shades on the skylights of the parked vehicle by 2/3 when there is strong sunlight.

### 6.5.1 Skylight with snap latch



Fig. 24 Skylight with snap latch

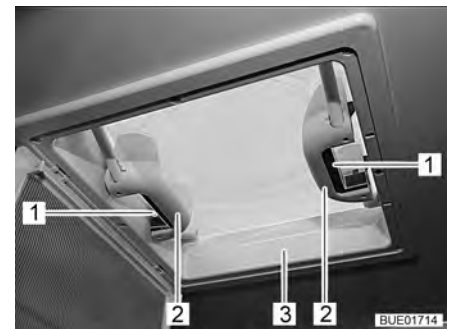

Fig. 25 Handles with snap latches

The skylight can be pushed upwards either from one side or from both sides.

*Opening:*

- Use handle (Fig. 24,1) to swing down the insect screen (Fig. 24,2).
- Push the snap latch (Fig. 25,1) towards the inside of the skylight (Fig. 25,3). At the same time use the handle (Fig. 25,2) to press the skylight upwards.
- Swing insect screen upwards until it latches in place.

*Closing:*

- Use handle (Fig. 24,1) to swing down the insect screen (Fig. 24,2).
- Using both handles (Fig. 25,2), pull down the skylight (Fig. 25,3) with force until the two snap latches (Fig. 25,1) lock into place.
- Swing insect screen upwards until it latches in place.

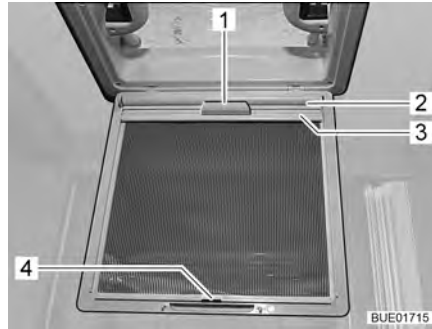

Fig. 26 Blind (skylight)

**Blind** Depending on the equipment, there will be a blind installed.

- Closing:**
- Use handle (Fig. 24,1) to swing down the insect screen (Fig. 24,2).
  - Using the handle (Fig. 26,1), pull out the blind (Fig. 26,2) and hook the retainer (Fig. 26,3) into the hook (Fig. 26,4) on the insect screen.
  - Swing insect screen upwards until it latches in place.
- Opening:**
- Use handle (Fig. 24,1) to swing down the insect screen (Fig. 24,2).
  - Release the retainer (Fig. 26,3) from the hook (Fig. 26,4) and, using the handle (Fig. 26,1), slowly return the blind (Fig. 26,2).
  - Swing insect screen upwards until it latches in place.

### 6.5.2 Hinged skylight



- ▷ If it rains and the hinged skylight is in ventilation position, that could lead to water penetrating the living area. Therefore close hinged skylight completely.

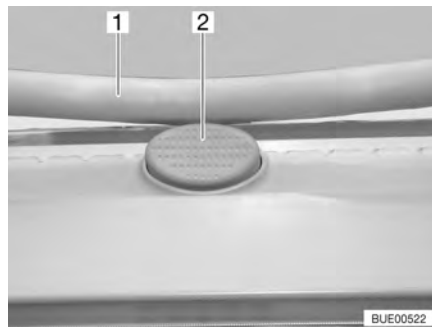

Fig. 27 Safety knob (hinged skylight)

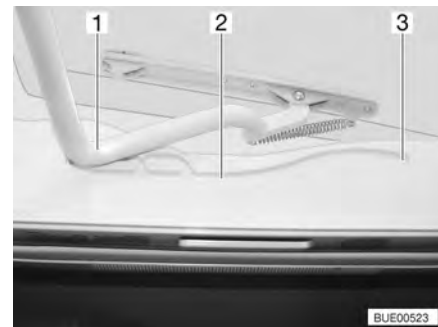

Fig. 28 Guide (hinged skylight)

The hinged skylight is opened on one side only.

- Opening:**
- Press the safety knob (Fig. 27,2) and pull the bar (Fig. 27,1) down with both hands.
  - Pull the bar (Fig. 28,1) in the guides (Fig. 28,2) to the rearmost position (Fig. 28,3).
- Closing:**
- Use both hands to push the bar (Fig. 28,1) slightly upwards.
  - Push the bar back in the guides.
  - Push the bar upwards with both hands until it is above the safety knob (Fig. 27,2).

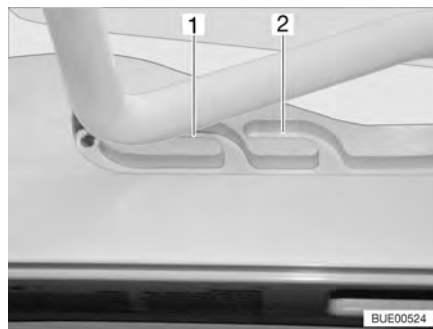

Fig. 29 Guide (ventilation position)

**Ventilation position**

The hinged skylight can be put in two ventilation positions: Bad weather position (Fig. 29,1) and central position (Fig. 29,2).

- Press the safety knob (Fig. 27,2) and pull the bar (Fig. 27,1) down with both hands.
- Pull the bar in the guides (Fig. 28,2) to the desired position.
- Push the bar slightly upwards and into the selected guide (Fig. 29,1 or 2).

**Roman shade**

To close and open the Roman shade:

*Closing:*

- Pull out Roman shade at the handle and release in the required position. The Roman shade will stay in that position.

*Opening:*

- Slowly push the Roman shade at the handle to its initial position.

**Insect screen**

To close and open the insect screen:

*Closing:*

- Pull the insect screen by the handle to the opposite handle of the Roman shade.

*Opening:*

- Press the rear part of the handle of the insect screen. The latch is released.
- Use handle to return the insect screen slowly to its initial position.

**6.6 Elevating roof**



- ▶ Risk of fatal injury from lightning!  
In the event of a storm, do not sit or stand beneath the elevating roof. A lightning strike could fatally injure someone standing or sitting under the elevating roof.
- ▶ Before commencing the journey, close and lock the elevating roof.
- ▶ Only close the elevating roof when the canvas is dry. What to do if the elevating roof must be closed when the canvas is wet: Open the elevating roof again as quickly as possible and allow the canvas to dry completely.



- ▷ Before every journey, make sure that the elevating roof is closed properly, that it cannot open by itself and that it is locked.  
If the elevating roof is elevated or not secured when the vehicle is in motion, the roof could catch against trees, signs, masts, car park entrances or other objects, ripping off and causing severe damage to the vehicle and third party property.
- ▷ Before closing the elevating roof, always close the zip fasteners and the Velcro straps on the ventilation openings.
- ▷ Open a window or the entrance door before closing the elevating roof. This prevents a build-up of trapped air from forming. If a build-up of trapped air forms, the mechanical components could damage the canvas.
- ▷ Ensure that the canvas is not trapped between the elevating roof and the vehicle roof.
- ▷ If the vehicle is not to be used for a prolonged period:
  - Air the interior thoroughly every 3 weeks. The elevating roof must be open for this.
  - Set up de-humidifiers (granulate). Follow the manufacturer's instructions. If the humidity in the interior is higher for an extended period, mildew and mould can form.



- ▷ The zip fasteners or Velcro straps of the ventilation openings in the canvas of the elevating roof can be opened for additional ventilation.

The elevating roof is lifted on one side.

### Passage to the elevating roof

When the elevating roof is not used, the passage to the elevating roof can be closed with a cover.

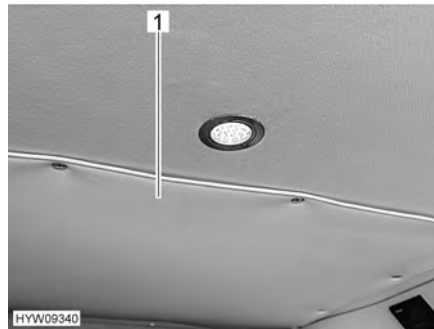

Fig. 30 Cover (closed)

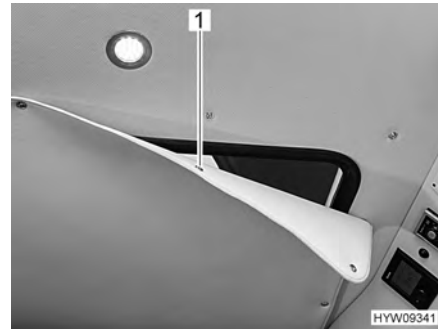

Fig. 31 Cover (partially open)

#### Opening the passage:

- Remove the cover (Fig. 30,1) in the roof lining of the living area. In order to do this, release the snap fasteners (Fig. 31,1).

#### Closing the passage:

- Fasten the cover with snap fasteners to the roof lining of the living area.

When the elevating roof is closed, it is secured by a quick-action turnbuckle with additional snap lock on the left and right side.



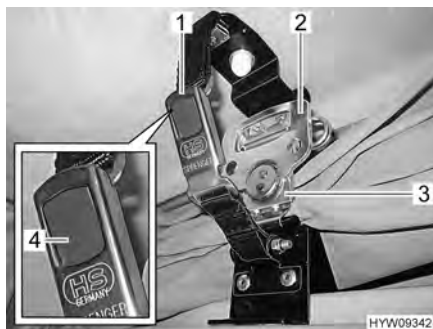

Fig. 32 Lock (elevating roof)

*Opening the elevating roof:*

- Open the snap lock (Fig. 32,1) on both sides. In order to do this, press the grey tongue (Fig. 32,4).
- On each side, fold out the handle (Fig. 32,2) of the quick-action turnbuckle (Fig. 32,3) and turn a quarter turn in an anticlockwise direction. Thus, the lock is released.
- Press slightly against the elevating roof. The elevating roof swivels upwards autonomously.

**Access ladder**

Always use the access ladder provided to climb up to the lying surface in the elevating roof. The access ladder is divided and must be plugged together and locked with the locks on the sides prior to use.

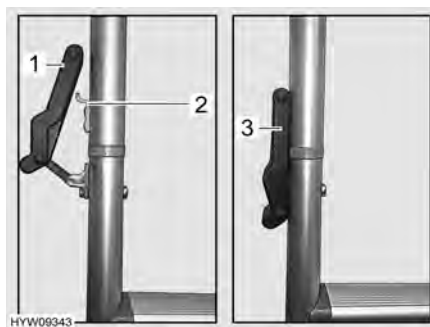

Fig. 33 Lock (access ladder)



Fig. 34 Access ladder (attached)

*Using the access ladder:*

- Plug both parts of the access ladder together.
- Hook the rubber fasteners (Fig. 33,1) into tongue (Fig. 33,2) and press downwards on both sides. Make sure that the rubber fasteners (Fig. 33,3) are in firm contact to the side rails.
- Hook the access ladder with the two brackets (Fig. 34,1) into the U-bolts (Fig. 34,2) on the frame of the elevating roof.

*Storing the access ladder:*

- Unhook the brackets of the access ladder from the tongues.
- Release the rubber fasteners (Fig. 33,3).
- Disassemble the access ladder.
- Store both parts of the access ladder securely.

**Ventilation** When the elevating roof is open, a fabric flap can be opened for ventilation.

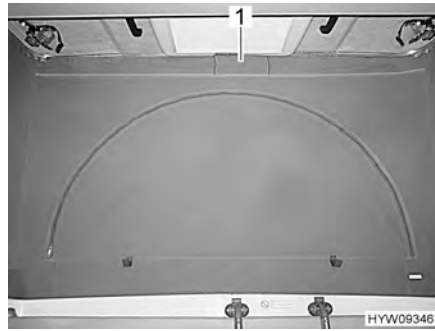

Fig. 35 Ventilation (closed)

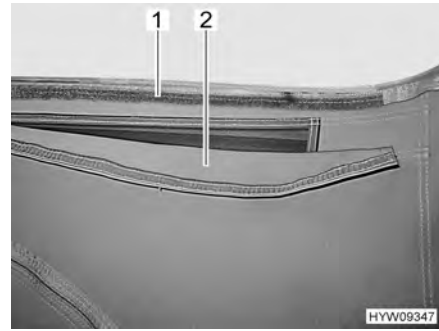

Fig. 36 Ventilation (open)

*Opening the ventilation:*

- Release the Velcro of the fabric flap (Fig. 35,1) underneath the elevating roof. A mesh is installed behind the fabric flap as protection from insects.

*Closing the ventilation:*

- Pull the fabric flap (Fig. 36,2) upwards and press down the Velcro strap (Fig. 36,1).



Fig. 37 Auxiliary strap (elevating roof)

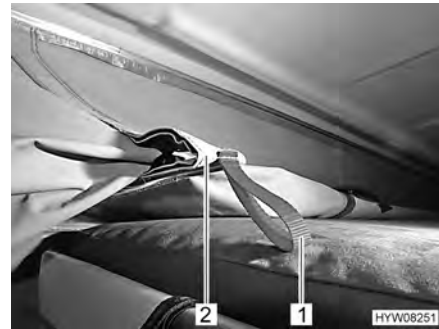

Fig. 38 Retraction device (elevating roof)

*Closing the elevating roof:*

- Slowly pull down the elevating roof by the auxiliary strap (Fig. 37,1) until the elevating roof remains in this position by itself. When doing this, make sure that the side retraction devices (Fig. 38,2) bend inwards.
- If the retraction devices are not bent inwards: Open the elevating roof again and close it more slowly.
- Pull in the canvas by the red tabs (Fig. 38,1) of the retraction devices (Fig. 38,2).

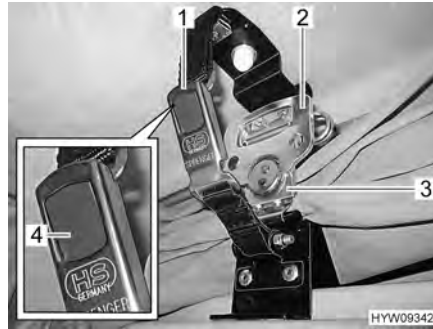

Fig. 39 Lock (elevating roof)

- On both sides, pull down the quick-action turnbuckle (Fig. 39,3) and hang it into the holding plate.
- On each side, fold out the handle (Fig. 39,2) of the quick-action turnbuckle and turn half a turn in a clockwise direction.
- Plug both parts of the snap lock (Fig. 39,1) together, respectively. The grey tongue (Fig. 39,4) engages.
- Close the passage to the elevating roof with the cover (Fig. 30,1).

## 6.7 Rotating seats



- ▶ Before commencing the journey, rotate all swivel seats in the direction of travel and lock in position. During the journey, the swivel seats must remain locked in place in the direction of travel.



- ▷ Mercedes-Benz base vehicle: For the change between driving position and living position, rotate the driver's and front passenger's seats only inwards (refer to Fig. 41). The map pocket on the inside of the doors could otherwise get damaged.

The lever for rotating the seat is located at the left or the right of the seat.



Fig. 40 Driver's seat and front passenger's seat

*Rotating:*

- Push both armrests at the driver's/front passenger's seat upward.
- Push the driver's seat/front passenger's seat backwards or into the central position.
- Actuate the lever (Fig. 40,1) to rotate the seat. The seat is released from the locking device.



Fig. 41 Observe the direction of rotation of driver's/front passenger's seat

- Rotate seat inwards in the direction of the vehicle interior until reaching the desired position.

## 6.8 Storage spaces



- ▶ Follow the safety instructions (sticker) that indicate when a space may not be used as a storage space (e.g. gas bottle compartment or spaces close to electrical wiring).
- ▶ Observe the permissible loads on front and rear axles, and the permissible total weight (see section 3.2.3).
- ▶ Do not transport fluids in the living area that emit gases hazardous to health.
- ▶ Close fluid containers tightly, secure them against sliding and against falling over.
- ▶ Always store heavy objects safely and slip-proof in the foot area. Lighter objects can be also stored safely in higher areas.



- ▷ Do not store wet clothes in cabinets or storage spaces.



- ▷ While storing the load, take into account how accessible the different objects should be, and how often they are used.

In the vehicle, there are the following possibilities for storage:

- Double floor area
- Wall-mounted cupboards

### 6.8.1 Storage compartment in double floor



- ▷ Depending on the equipment, a carpet segment will have to be put aside to gain access to the storage compartments.

The storage compartments are accessible through lids in the living area. The disposition of the storage compartments is dependent on the model.

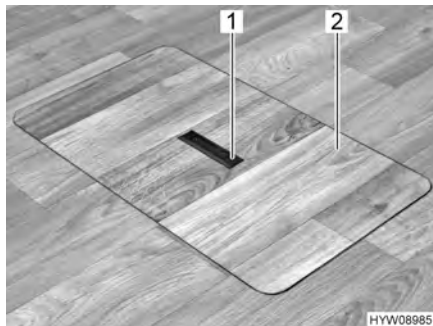

Fig. 42 Floor storage compartment cover (handle recessed)



Fig. 43 Floor storage compartment cover (handle swung out)

*Opening:*

- If necessary, lay carpet segment aside.
- Push one side of the grip plate (Fig. 42,1) downwards. The handle (Fig. 43,1) swivels upwards.
- Remove the cover (Fig. 43,2) upwards.



- ▶ Close the lid and recess the handle as soon as possible. Otherwise, there will be danger of tripping due to the open floor storage compartment or the protruding handle.
- ▶ Do not bend the carpet segments.
- ▶ Do not leave the carpet segments laying in the room. Danger of tripping!

*Closing:*

- Insert the cover (Fig. 43,2) in the frame on the floor.
- Swivel handle downwards.

## 6.9 Tables

### 6.9.1 Suspension table, folding

The vehicle is fitted with a suspension table with fold-out table top extension.



Fig. 44 Table

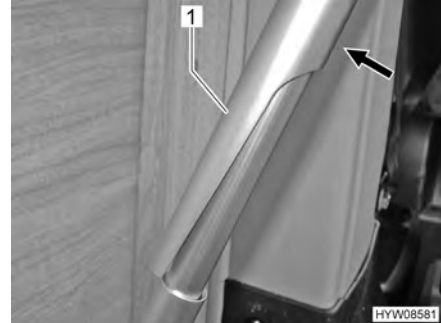

Fig. 45 Support leg (unlocked)

#### *Extending:*

- Pull out the two supports (Fig. 44,1).
- Pull out securing button (Fig. 44,3) and remove retaining belt from the table top extension (Fig. 44,2).
- Fold out the table top extension (Fig. 44,2).

#### *Reducing size:*

- Fold up the table top extension (Fig. 44,2).
- Press securing button (Fig. 44,3) of the retaining belt onto the holder on the table top extension.
- Push in the two supports (Fig. 44,1).

The suspension table can also be folded away.

#### *Folding the table top away:*

- Slightly raise the front of the table top (Fig. 44,4).
- Press the upper part of the table leg (Fig. 45,1) towards the exterior wall (Fig. 45).
- Keep pressing down on the upper part and let the table drop down.

## 6.9.2 Suspension table with separable support leg



- ▷ The maximum permissible load on the swung-out table top extension is 3 kg.



Fig. 46 Suspension table with separable support leg

The suspension table size can be enlarged by swinging out a table top extension.

- Extending:*
- Pull the knob (Fig. 46,2) of the lock down and swing out the table top extension (Fig. 46,1).

- Reducing size:*
- Swing the table top extension (Fig. 46,1) under the table top (Fig. 46,6) until the lock latches in place audibly.

The suspension table's separable support leg enables it to be used as a bed foundation.

- Conversion to bed foundation:*
- Lift the front of the table top (Fig. 46,6) by approx. 45°.
  - Pull out the lower part of the support leg (Fig. 46,4) down and lay aside.
  - Remove the table top from the upper retainer.
  - Hook the table top at a 45° angle to the supports into the lower retainer (Fig. 46,3) and place on the floor with the upper part of the support leg (Fig. 46,5).

### 6.9.3 Folding worktop



- ▷ The folding worktop is designed only for minimal loads (e.g. kitchen utensils). Do not use the folding worktop as a repository for heavy objects.

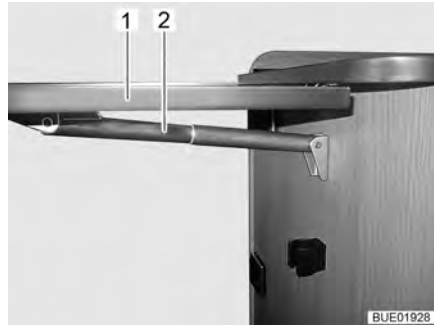

Fig. 47 Folding worktop

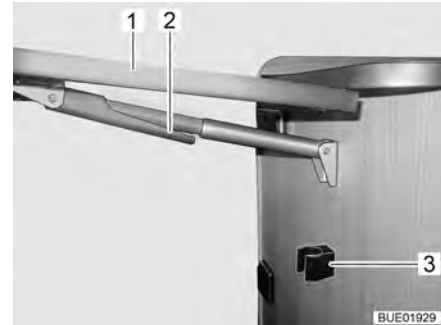

Fig. 48 Folding away the folding worktop

To increase the size of the kitchen work surface, a folding worktop can be folded out at the side of the kitchen counter.

*Bringing the folding worktop into the work position:*

- Hold the folding worktop (Fig. 47,1) from below and pull gently to release it from the lock position.
- Swing up the worktop until the fixture of the telescopic holder (Fig. 47,2) engages. Let go of the worktop.

*Bringing the folding worktop into the travel position:*

- Hold the folding worktop (Fig. 48,1) at the edges and lift gently. With your other hand, swing down the fixture (Fig. 48,2) on the telescopic holder.
- Fold down the worktop until the telescopic holder clicks into position in the holder (Fig. 48,3).



### 6.10 TV unit

An external satellite antenna may be connected to the vehicle's TV unit. The connection for the external satellite antenna is installed behind the driver's seat, in the B column.



- 1 SAT socket (input)
- 2 12 V socket

Fig. 49 Sockets (external satellite antenna)

*Connecting external satellite antenna:*

- Plug the external satellite antenna's connecting cable into the SAT socket (Fig. 49,1).

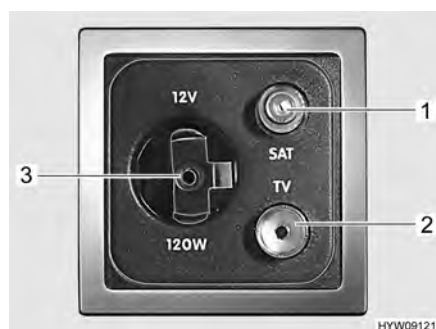

- 1 SAT socket (output)
- 2 DVB-T port (output)
- 3 12 V socket

Fig. 50 Sockets (TV unit)

*Receiving satellite channels:*

- Plug the suitable cable of the television into the SAT socket (Fig. 50,1).

*Receiving terrestrial channels:*

- Plug the suitable cable of the television into the DVB-T port (Fig. 50,2).

## 6.11 Smoke alarm

A smoke alarm is installed on the ceiling of the vehicle. The smoke alarm has its own battery and is not connected to the vehicle's power supply. This means that the smoke alarm still works even if the vehicle's power supply is switched off.

If smoke is produced in the vehicle, a loud alarm tone sounds to warn of a possible fire.



- ▷ The smoke alarm can neither prevent nor extinguish fires. However, the smoke alarm can help make sure that the vehicle is evacuated in a timely manner.

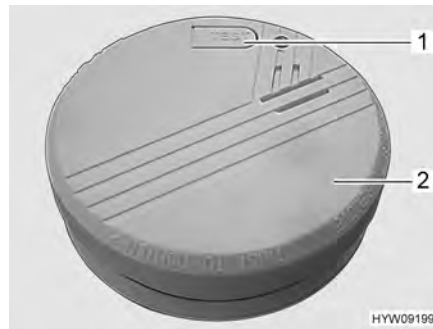

Fig. 51 Smoke alarm

*Activating the smoke alarm:*

- Remove the protective film from the battery and put in the battery (see section 12.5).

*Testing the smoke alarm:*

- Press the test button (Fig. 51,1) on the smoke alarm (Fig. 51,2) until the alarm tone sounds. The alarm tone falls silent after the test button is released.



- ▷ Test the smoke alarm once weekly, as well as after changing the battery and after cleaning.
- ▷ When the smoke alarm's battery is almost flat, a warning tone sounds with an interval of 30 to 40 seconds. Replace the battery as quickly as possible (see section 12.5).
- ▷ Further information can be obtained in the device manufacturer's instruction manual.

## 6.12 Beds

### 6.12.1 Rear bed



- ▶ Always secure loads onto the clamping eyelets. Always use tightening straps or lashing nets for securing the load, never rubber expanders.
- ▶ Do not let the bed fall down when closing it!

Depending on the model, the space under the bed can be used for storage. Fold up the bed to store items in or remove them from the storage space and when transporting larger objects (e.g. bicycles).

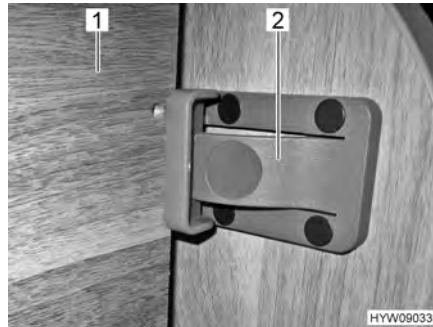

Fig. 52 Securing, front

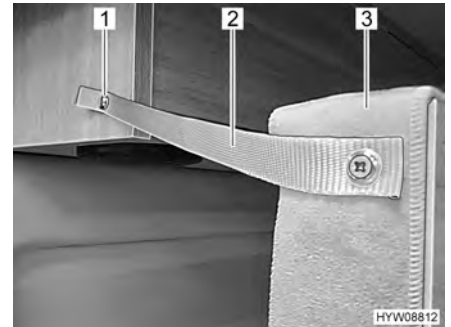

Fig. 53 Securing, back

#### Opening:

- Lift bed (Fig. 52,1).
- Secure the bed (Fig. 53,3) to the roof cabinet with the securing strap (Fig. 53,2) and snap fastener (Fig. 53,1).
- Use the latch (Fig. 52,2) to secure the bed on the furniture wall.

#### Closing:

- Press the latch (Fig. 52,2).
- Undo the snap fastener (Fig. 53,1) on the roof cabinet.
- Hold the bed and guide it all the way down.

### 6.12.2 Bed in the elevating roof



- ▶ Risk of fatal injury from lightning!  
In the event of a storm, do not sit or stand beneath the elevating roof. A lightning strike could fatally injure someone standing or sitting under the elevating roof.
- ▶ The maximum permitted load on the bed in the elevating roof is 200 kg.
- ▶ Before commencing the journey, secure the bed. To do this, fold in and lock the elevating roof.
- ▶ Only use the bed, if the safety net is set up.
- ▶ Never leave small children in the elevating roof bed without supervision.
- ▶ In particular with regard to small children under 6 years of age, users should ensure that they cannot fall out of the elevating roof bed.
- ▶ Use separate children's beds or travel cots suitable for children.



- ▷ Do not use the bed in the elevating roof for luggage storage. When the bed is not being used, only keep the bed linen required for 2 people and the access ladder in it.
- ▷ Never pull down the bed in the elevating roof together with the elevating roof.

Depending on the model, the vehicle is fitted with a elevating roof. The bed in the elevating roof can be used immediately without additional conversions after the elevating roof has been opened (see section 6.6).

**Safety net** Do not use the safety net until the persons are already in bed.

**Access ladder** Always use the access ladder provided to climb up to the bed in the elevating roof (see section 6.6).

**6.12.3 Additional bed (conversion of the seating group)**



- ▷ Depending on the equipment, the seating group can be converted into a further sleeping place.
- ▷ Before converting the table into the bed foundation: lift seat cushion or fold it upwards such that the table top does not collide with the seat cushions when moving.

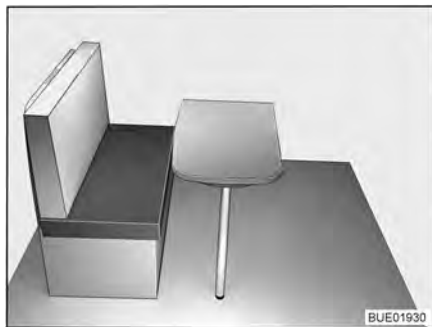

Fig. 54 Prior to conversion

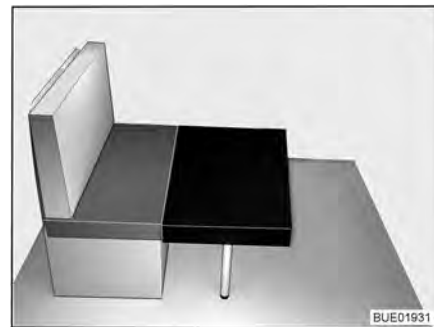

Fig. 55 Conversion (1)

- If present, fold down the folding worktop.
- Convert the suspension table into a bed foundation (see section 6.9.2).
- Place the small additional cushion onto the table in front of the seat cushion of the bench (refer to Fig. 55).



Fig. 56 Conversion (2)

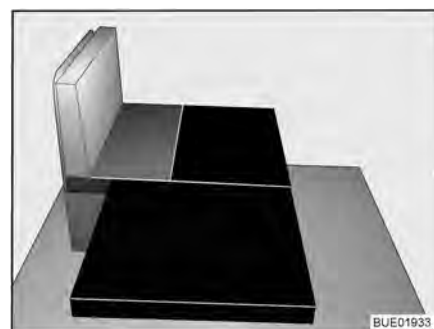

Fig. 57 After conversion

- Insert the journals on the bottom side of the cushion support into the recesses on the bench. In order to do this, lift the seat cushion slightly.
- Fold out the support legs of the cushion support. Put the cushion support down on the support legs.
- Place large additional cushion on the cushion support (refer to Fig. 57).



## Chapter overview

This chapter contains instructions regarding the gas system of the vehicle. The operation of the gas operation appliances of the vehicle is described in chapter 9.

### 7.1 General



- ▶ The operator of the gas system is responsible for the performance of recurring inspections and for complying with the maintenance intervals.
- ▶ Before commencing the journey, when leaving the vehicle or when gas equipment is not in use, close all gas isolator taps and the main isolator tap on the gas bottle.
- ▶ All gas-operated devices (heater, cooker, oven, grill, refrigerator - depending on the equipment) must be switched off for refuelling, on ferries or in the garage. Danger of explosion!
- ▶ Do not use gas-operated devices in closed spaces (e.g. garages). Danger of poisoning and suffocation!
- ▶ Only have the gas system maintained, repaired or altered by an authorised specialist workshop.
- ▶ Have the gas system checked by an authorised specialist workshop according to the national regulations before commissioning. This also applies for not registered vehicles. For modifications to the gas system have the gas system immediately checked by an authorised specialist workshop.
- ▶ The gas pressure regulator, the gas tubes, and the exhaust gas pipes must also be inspected. The gas pressure regulator and the gas tubes must be replaced observing the nationally defined deadlines (the latest after 10 years). The vehicle owner is responsible for seeing that this is carried out.
- ▶ In case of a defect of the gas system (gas odour, high gas consumption) there is danger of explosion! Close regulator tap on the gas bottle immediately. Open doors and windows and ventilate well.
- ▶ If the gas system is defective: Do not smoke; do not ignite any open flames, and do not operate electric switches (light switches etc.). Check the tightness of gas-conducting parts and lines with leakage search spray. Do not check with an open flame.
- ▶ Only the stipulated devices may be connected to internal connections. Do not operate any device outside the vehicle if it is connected to an internal connector.
- ▶ Before using the cooker make sure that there is sufficient ventilation. Open a window or the skylight.
- ▶ Do not use gas-operated cooking and baking facilities for heating purposes.
- ▶ If there are several gas devices, each gas device must have its own gas isolator tap. If individual gas devices are not in use, close the respective gas isolator tap.
- ▶ Ignition safety valves must close within 1 minute after the gas flame has extinguished. A clicking sound is audible. Check function from time to time.



- ▶ The built-in gas devices are exclusively meant for use with propane or butane gas or a mixture of both. The gas pressure regulator as well as all built-in gas devices are designed for a gas pressure of 30 mbar.
- ▶ Propane gas is capable of gasification up to -42 °C, whereas butane gas gasifies at 0 °C. Below these temperatures no gas pressure is available. Butane gas is unsuitable for use in winter.
- ▶ Due to its function and construction, the gas bottle compartment is a space which is open to the exterior. Never cover or block up the standard forced ventilations. Otherwise gas that is emitted can not be diverted to the outside.
- ▶ The gas bottle compartment must not be used as storage space.
- ▶ Secure the gas bottle compartment against unauthorised access. To do this, lock the compartment.
- ▶ The regulator tap on the gas bottle must be accessible.
- ▶ Only connect gas-operated devices (e.g. gas grill) which have been designed for a gas pressure of 30 mbar.
- ▶ The exhaust gas pipe must be fitted tightly to the heating system and to the vent and must be sealed. The exhaust gas pipe must not show any evidence of damage.
- ▶ Exhaust fumes must be able to escape into the atmosphere unhindered and fresh air must be able to enter unhindered. For this reason, keep the exhaust pipe and intake openings clean and unobstructed (e.g. free from snow and ice). For this reason, no snow walls or aprons may lie against the vehicle.

### 7.2 Gas bottles



- ▶ Handle full or emptied gas bottles outside the vehicle only with closed regulator tap and attached protective cap.
- ▶ Gas bottles are only to be transported within the designated gas bottle compartment.
- ▶ Place the gas bottles in vertical position in the gas bottle compartment.
- ▶ Fasten the gas bottles so that they are unable to turn or tilt.
- ▶ Connect the gas tube to the gas bottle without tension.
- ▶ If the gas bottles are not connected to the gas tube, always place the protective cap on top.
- ▶ Close the regulator tap on the gas bottle before the gas pressure regulator or gas tube are removed from the gas bottle.
- ▶ Depending on the connection, unscrew the gas tube from the gas bottle and screw it on the gas bottle again by hand or using a suitable special spanner. The screw connection on the gas bottle generally has a left-hand thread. **Do not** tighten too firmly.
- ▶ Only use special gas pressure regulators with a safety valve designed for vehicle use. Other gas pressure regulators are not permitted and cannot meet the demanding requirements.
- ▶ Use the gas pressure regulator defroster if the temperature falls below 5 °C.





- ▶ The designated gas bottle compartment will accommodate two gas bottles, i. e. Calor Gas Butane/Propane or Camping Gaz. All gas bottles **must** be fitted with the appropriate regulator.
- ▶ Use the shortest possible tube lengths (150 cm max.) for external gas bottles.
- ▶ Never block the floor ventilation openings below the gas bottles.



- ▷ For gas-operated units the gas pressure must be reduced to 30 mbar.
- ▷ Connect gas pressure regulator complete with safety valve directly to bottle valve.

The gas pressure regulator reduces the gas pressure in the gas bottle down to the operating pressure of the gas devices.

- ▷ For filling and connecting the gas bottles in Europe the accessories shops have corresponding Euro filling sets and Euro bottle sets.
- ▷ Information available at the dealers or service centre.

### 7.3 Gas isolator taps

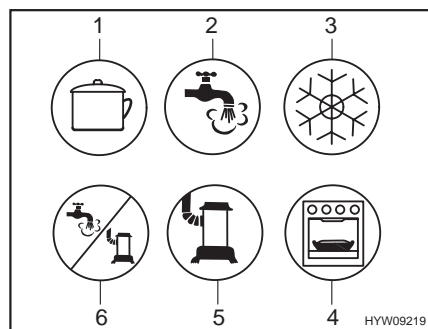

- 1 Cooker
- 2 Hot water
- 3 Refrigerator
- 4 Oven/grill
- 5 Heater
- 6 Hot water/heater

Fig. 58 Possible symbols for the gas isolator taps

A gas isolator tap (Fig. 58) for every gas device is built into the vehicle. The gas isolator taps can be found under the cooker.

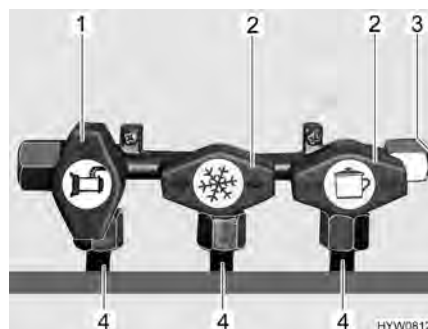

- 1 Gas isolator tap open
- 2 Gas isolator tap closed
- 3 Gas pipe
- 4 Pipe to the gas appliance

Fig. 59 Gas shut-off valves position (example)

- Opening:**
- Position the gas isolator tap of the corresponding appliance parallel (Fig. 59,1) to the pipe (Fig. 59,4) leading to the gas appliance.
- Closing:**
- Position the gas isolator tap of the corresponding appliance transverse (Fig. 59,2) to the pipe (Fig. 59,4) leading to the gas appliance.

## 7.4 Gas pressure regulating system DuoControl CS



- ▷ The regulating system and the hose lines shall be changed at the latest 10 years after manufacturing date. The operator is responsible for this.
- ▷ Also read the manufacturer's instruction manual.

DuoControl CS is a safety gas pressure regulating system with automatic switching for a two-bottle gas system and with crash sensor. The DuoControl regulating system automatically switches the gas supply from the primary bottle to the reserve bottle as soon as the primary bottle is either empty or no longer ready for operation. The gas appliances may still continue operation. The DuoControl regulating system is suitable for all commercial gas bottles with liquefied gas (propane/butane) and a pressure of 0.6 bar to 16 bar.

The DuoControl regulating system ensures a constant gas pressure for the gas-operated devices, no matter which gas bottle is supplying the gas.

In the event of an accident, the crash sensor in the DuoControl regulating system will interrupt the gas flow.

The gas bottles are connected via high pressure hoses. A hose break guard prevents gas leakage in the event of a damaged hose.

The operation of gas-operated devices during the journey is permitted in all of Europe if the vehicle is equipped with a gas pressure regulating system with crash sensor and high-pressure hoses with hose break guard.

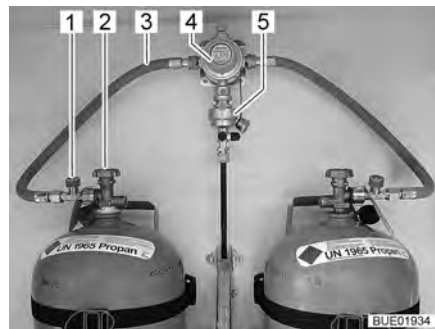

Fig. 60 Gas bottles with DuoControl

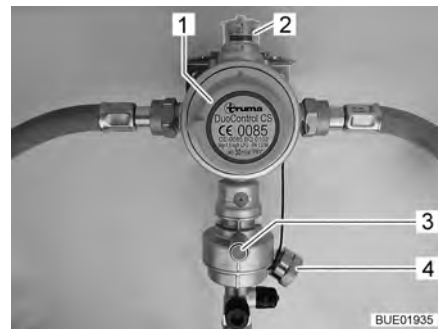

Fig. 61 DuoControl regulating system

### Construction of the unit

The DuoControl regulating system consists of a reversing valve (Fig. 60,4) and a crash sensor (Fig. 60,5). The DuoControl regulating system is installed between the gas tubes (Fig. 60,3) with hose break guard (Fig. 60,1). The knob (Fig. 61,1) on the reversing valve is used to select which of the gas bottles is to be used as primary bottle and which is to be used as reserve bottle.

The status of the gas supply is indicated in the inspection window (Fig. 61,2):

- Green: Gas is taken out of the primary bottle.
- Red: Gas is taken out of the reserve bottle.

The operation with only one gas bottle is allowed but in this case the open connection must be closed with a blind cover (Fig. 61,4).

### Crash sensor

The crash sensor blocks the gas supply in the event of a significant impact (e.g. accident). The crash sensor is put into operation with the green reset button (Fig. 61,3).

### Hose break guard

The hose break guard (Fig. 60,1) blocks the gas flow if the connected hose breaks. The hose break guard must be activated by pressing the green button.

**Defroster** The DuoControl regulating system can be heated (defroster). If winter operation is set at the operating unit, the DuoControl regulating system will be heated automatically. Thus, faults of the gas system due to frost in winter are prevented.



- 1 Yellow indicator lamp, defroster
- 2 Winter operation position
- 3 OFF position
- 4 Summer operation position
- 5 Red indicator lamp, primary bottle empty
- 6 Green indicator lamp, supply from primary bottle
- 7 Rocker switch

Fig. 62 Operating unit (DuoControl)

**Operating unit** At the operating unit (Fig. 62), the gas supply via the DuoControl regulating system is switched on and off. The regulator taps (Fig. 60,2) of the gas bottles and the gas isolator taps of the devices must be opened manually.

Summer and winter operation are switched with the rocker switch (Fig. 62,7) on the operating unit.

The two indicator lamps on the operating unit indicate the level of the primary bottle. When the green indicator lamp (Fig. 62,6) is lit, the primary bottle is sufficiently filled. When the red indicator lamp (Fig. 62,5) illuminates, the primary bottle is empty. In this case, the reserve bottle is used for the gas supply.

*Putting into operation:*

- Connect the gas bottles.
- Use the knob (Fig. 61,1) on the reversing valve to select the gas bottle which is to be the primary source of gas (primary bottle). Always turn the knob as far as it will go.
- Open regulator taps (Fig. 60,2) on the gas bottles.
- Press the green button of the hose break guard (Fig. 60,1). The green marking is shown in the inspection window (Fig. 61,2).

*Switching on summer/winter operation:*

- Switch on the DuoControl regulating system at the operating unit (Fig. 62). To do so, set the rocker switch (Fig. 62,7) to winter operation (Fig. 62,2) or to summer operation (Fig. 62,4). The yellow defroster indicator lamp (Fig. 62,1) is lit when winter operation is selected.

*Switching off:*

- Set the rocker switch (Fig. 62,7) to the OFF position (Fig. 62,3). The indicator lamps go out.
- Close regulator taps (Fig. 60,2) on the gas bottles.

### Changing gas bottles



- ▶ When changing gas bottles, do not smoke or create any open fire.
- ▶ When you have changed the gas bottle, check whether gas escapes at the connection points and unions. Use a leakage search spray to spray the relevant connection point or union. These agents are available at the accessories shop.

If the green indicator lamp (Fig. 62,6) goes out during operation and the red indicator lamp (Fig. 62,5) lights up, the primary bottle is empty and must be changed. The red marking is shown in the inspection window (Fig. 61,2). The reserve bottle continues supplying the gas appliances with gas.

You may also change an empty gas bottle while gas-operated devices are in operation.

#### *Changing the gas bottle:*

- Turn the knob (Fig. 61,1) a half turn in the direction of the currently used gas bottle. In this way, this gas bottle is the primary bottle now, and the empty gas bottle becomes the reserve bottle. The marking in the inspection window (Fig. 61,2) changes from red to green.
- Close regulator tap (Fig. 60,2) on the empty gas bottle. Pay attention to the direction of the arrow.
- Unscrew the gas tube from the empty gas bottle (normally a left-hand thread).
- Release the fixing belts and remove the empty gas bottle.
- Place a filled gas bottle in the gas bottle compartment and retain with the fixing belts.
- Connect gas tube to the filled gas bottle (normally a left-hand thread).
- Open the regulator tap on the gas bottle.
- Press the green button of the hose break guard (Fig. 60,1).

## Chapter overview

This chapter contains instructions regarding the electrical system of the vehicle.

The operation of the electrical appliances of the housing body is described in chapter 9.

### 8.1 General safety instructions



- ▶ Only allow qualified personnel to work on the electrical system.
- ▶ All electronic devices (e.g. mobile telephones, radios, televisions or DVD players) which have been retrofitted to the vehicle and are operated during the journey must have certain features: These are the CE certification, the EMC inspection (electromagnetic compatibility) and the "e"-inspection.

Only in this way can the functional reliability of the vehicle be ensured. Otherwise the airbag may be triggered or interference to the on-board electronics may result.



- ▷ After the vehicle is started, delays to the output or forwarding of electrical impulses are possible.

The control unit of the basic vehicle does not release the D+ signal until the engine has reached full performance. In the event of a cold start in winter, this can take up to 15 seconds.

For this reason, output of warning signals (such as "entrance step extended") may sometimes be delayed.

The automatic retraction of a SAT antenna can also be delayed.

- ▷ During a storm, to protect the electrical devices disconnect the 240 V connection and retract the antennae.

### 8.2 Terms

#### Off-load voltage

The off-load voltage is the voltage of the battery in idle condition, i.e. no current is consumed and the battery is not being charged.



- ▷ The battery must remain idle for a while before measuring. After charging the last time, or after the last current has been drained by appliances, wait approximately 2 hours before measuring the off-load voltage.

#### Closed circuit current

Some electrical appliances, such as the clock and the indicator lamps, require continuous electric current, for this reason they are referred to as inactive appliances. This closed circuit current flows even if the device has been switched off.

#### Total discharge

Total discharge of the battery is imminent, if a battery is completely discharged by an active appliance and by closed circuit current and the off-load voltage falls below 12 V.



- ▷ Total discharge damages the battery.

**Capacity** Capacity refers to the amount of electricity which can be stored in a battery. The capacity of a battery is given in ampere hours (Ah). The so-called K20 value is normally used.

The K20 value indicates how much current a battery is able to dispense over a time period of 20 hours without causing damage, or how much current is required to charge a flat battery within 20 hours.

For example, if a battery can dispense 4 amps for 20 hours, then it has a capacity of  $4 \text{ A} \times 20 \text{ h} = 80 \text{ Ah}$ .

If more current flows, the discharging time of the battery will decrease proportionately.

External influences, such as temperature and age may alter the storage capacity of the battery. Capacity details refer to new batteries operating at room temperature.



- ▷ Depending on battery technology, capacity details have a conversion factor of 1.3 to 1.7, which lowers the real capacity by this value.

## 8.3 12 V power supply

### 8.3.1 Starter battery

The starter battery serves for starting the engine and supplies the electrical appliances of the base vehicle as well as optional devices such as the radio, navigation system or central locking system with voltage.

**Position** See section 8.8.

**Discharging** This section contains information regarding the discharge of the starter battery.



- ▷ Total discharge damages the battery.
- ▷ Recharge battery in good time.

The starter battery will be totally discharged via a closed circuit current (inactive appliances). Inactive appliances are optional devices such as a radio, alarm system, navigation system or a central locking system. Inactive appliances discharge the starter battery when the vehicle engine is switched off.

Low temperatures outside reduce the capacity available.

**Charging** This section contains information regarding the charging of the starter battery.



- ▶ The acid in the battery is poisonous and corrosive. Any contact with the skin or the eyes is to be avoided. In the event of contact, rinse immediately with plenty of water (skin, eyes, clothes, objects) and seek medical attention if necessary.
- ▶ In the case of charging with an external charger there is danger of explosion. Sparks can be caused by attaching the battery terminals. Only charge the battery in a well ventilated area and away from naked flames or possible sources of sparks. Batteries can develop and release gases when they are charged.



- ▷ Never disconnect the battery while the engine is running.
- ▷ Before a temporary lay-up, charge the battery fully.
- ▷ Do not connect the battery cables to the wrong poles (red cable -> positive pole, black cable -> negative pole).
- ▷ If the starter battery or living area battery are disconnected, do not apply the ignition. There is a danger of short circuit from exposed cable ends.
- ▷ Before disconnecting or connecting the terminals of the battery, switch off the vehicle engine as well as the 240 V and 12 V power supplies and all appliances. Danger of short circuit!
- ▷ Observe the instruction manuals for the base vehicle and the charger.

The starter battery can only be fully charged with an external charger. When the vehicle is connected to the 240 V power supply, the transformer/rectifier charges the starter battery with a float charge only. Even in mobile operation, the vehicle engine alternator is not capable of completely charging the starter battery.

When charging the starter battery with an external charger, proceed as follows:

- Turn off the vehicle engine.
- Switch off the 12 V power supply on the panel. The indicator lamps or the displays on the panel go out.
- Switch off all gas appliances, all gas isolator taps and close the regulator tap on the gas bottle.
- Disconnect the starter battery from the vehicle (e.g. remove the battery terminals). There is a danger of short circuit when disconnecting the battery poles. For this reason, first disconnect the negative terminal on the starter battery and then the positive.
- Check that the external charger is turned off.
- Connect the external charger to the starter battery. Pay attention to the polarity: First connect the positive terminal "+" to the positive terminal of the starter battery, then connect the negative terminal "-" to the negative pole of the starter battery.
- Switch on the external charger.
- See the instructions for use of the connected charger for information concerning charge period required for the battery.
- See the specifications on the battery for information concerning its strength.
- Disconnect the charger in reverse order (the negative terminal first).
- Connect the battery terminals again (first the positive terminal).

### Storage

This section contains instructions on the storage of the starter battery.

- Store the disconnected battery in a cool and dry place.
- Connect the disconnected battery to a charger for 24 to 48 hours every 4 to 6 weeks.



- ▷ If the battery remains connected during a lay-up, it may become necessary to recharge already after 14 day or in even shorter intervals.
- ▷ If there is an "intelligent" charger with float charge functionality, have the charger connected to the battery and switched on over the entire lay-up time.

### 8.3.2 Living area battery



- ▷ The living area battery may not be opened.
- ▷ Use only the built-in transformer/rectifier to load the living area battery. In order to do this, connect the 240 V connection (CEE connector) of the vehicle to an external 240 V power supply.
- ▷ Prior to commencing a journey ensure the living area battery is fully charged. For this reason charge the living area battery for at least 20 hours before commencing the journey.
- ▷ During the trip, use every opportunity to charge the living area battery.
- ▷ After the trip, charge the living area battery fully.
- ▷ Before a temporary lay-up, charge the battery fully.
- ▷ When the living area battery is changed, only use batteries of the same type and the same capacity.
- ▷ When changing the battery, always disconnect the negative pole first and, then, the positive pole. When connecting, proceed in inverted order: connect the positive pole first and, then, the negative pole.
- ▷ When changing the living area battery, use only batteries for which there are charging characteristics available. After changing the battery the charging characteristics must be adjusted at the transformer/rectifier or at the auxiliary charging unit.
- ▷ If there are several living area batteries, always change all the batteries together. The batteries must **always** be the same age and have the same capacity.
- ▷ When changing the living area battery, use only batteries which meet the minimum capacity of the charger. Observe the separate instruction manual for the charger. Lower-capacity batteries will generate a great deal of heat when they are charged. Danger of explosion!
- ▷ If the living area battery is replaced and the charging unit does not provide at least 10 % of the rating of a new battery, install an auxiliary charging unit. Example: With a battery capacity of 80 Ah, the charging unit must supply at least 8 A charging current.
- ▷ Before disconnecting or connecting the terminals of the battery, switch off the vehicle engine as well as the 240 V and 12 V power supplies and all appliances. Danger of short circuit!
- ▷ If the starter battery or living area battery are disconnected, do not apply the ignition. There is a danger of short circuit from exposed cable ends.
- ▷ Only connect devices with a maximum of 10 A to the sockets of the 12 V power supply.
- ▷ If there are two living area batteries: When changing, ensure that the batteries are properly installed. Install the batteries so that the positive terminal on one battery is lying next to the negative terminal of the other battery.
- ▷ If there are two living area batteries: When changing, ensure that the batteries are properly connected.





- ▷ The battery is maintenance-free. Maintenance-free means:
  - It is not necessary to check the acid level.
  - It is not necessary to lubricate the battery poles.
  - It is not necessary to refill the distilled water.
  - Even a maintenance-free battery must be recharged.
  - Recommendation: perform a full charging cycle every 6 to 8 weeks.
  - Depending on the battery capacity and the charger, the charging cycle will last 24 to 48 hours.
- ▷ Depending on the model and equipment, an auxiliary battery is connected to the living area battery. Below the batteries are named as living area batteries, regardless of the number.

When the vehicle is not connected to the 240 V power supply or the 240 V power supply is switched off, the living area battery supplies the living area with 12 V DC. The living area battery has a limited power supply only. For this reason, electrical appliances such as the radio and the lights should not be operated for a long time without using the 240 V power supply.

**Position** See section 8.8.

**Discharging** The living area battery is discharged by the closed circuit current which some electrical appliances continuously require.



- ▷ Total discharge damages the battery.
- ▷ Recharge battery in good time.

Even a fully charged living area battery can, after an extended period, be fully discharged via a closed-circuit current (inactive appliances).

Low temperatures outside reduce the capacity available.

The self-discharge rate of the battery is also dependant on temperature. At 20 to 25 °C the self-discharge rate is approx. 3 % of the capacity per month. The self-discharge rate will increase with rising temperatures: At 35 °C the self-discharge rate is approx. 20 % of the capacity per month.

An older battery no longer has the complete capacity available.

The higher the number of active electrical appliances, the faster the energy of the living area battery is consumed.

**Charging** Only use the transformer/rectifier to charge the living area battery. Therefore, connect the vehicle to a 240 V power supply system as often as possible. As a principle, only use the 240 V connection on the vehicle (CEE socket outlet) for connecting.



- ▷ Charge the battery for at least 48 hours after a total discharge.
- ▷ At temperatures below 0 °C, a living area battery consumes less power. At approx. -15 °C, there will be no more power. The living area battery can no longer be charged.
- ▷ Always connect the load and charging lines cross-wise. This is necessary to ensure the batteries always have the same line resistance to one another. This allows the charging/discharging current to be distributed equally.

**Storage** This section contains instructions on the storage of the living area battery.

- Store the disconnected battery in a cool and dry place.
- In the case of a disconnected, fully charged gel battery it may suffice to recharge the battery after 6 months.  
Recommendation: also charge a gel battery for 24 to 48 hours every 4 to 6 weeks.



- ▷ If there is an "intelligent" charger with float charge functionality, have the charger connected to the battery and switched on over the entire lay-up time.

### 8.3.3 Energy balance of the living area battery

The living area battery has a limited power supply only. For this reason, the electrical appliances should not be operated without a 240 V power supply for a longer period of time.

### 8.3.4 Installation of converter



- ▷ Retrofitting of a converter can lead to damage to the electrical system. We will not be held liable for this damage.

The installation of a 240 V converter results in a very high current load. For example a converter with a power output of 800 W on the 12 V-side has a current consumption of up to 75 A.

This current is much too big for the outputs on the transformer (see section 8.7.1).

If the converter is connected directly to the battery, the current consumption of the converter will not be indicated by panel. Due to the high discharging current, the terminal voltage in the battery drops significantly. The measuring system installed then detects undervoltage and could switch off the 12 V power supply. In addition the living area battery will be drained very quickly if a converter is used. It is not possible to gain sufficient charge via the vehicle's alternator or the transformer.

## 8.4 Transformer/rectifier (EBL 30)



- ▷ Do not cover the ventilation slots. Danger of overheating!



- ▷ Depending on the model, not all slots for the fuses are occupied.
- ▷ Further information can be obtained in the manufacturer's instruction manual.

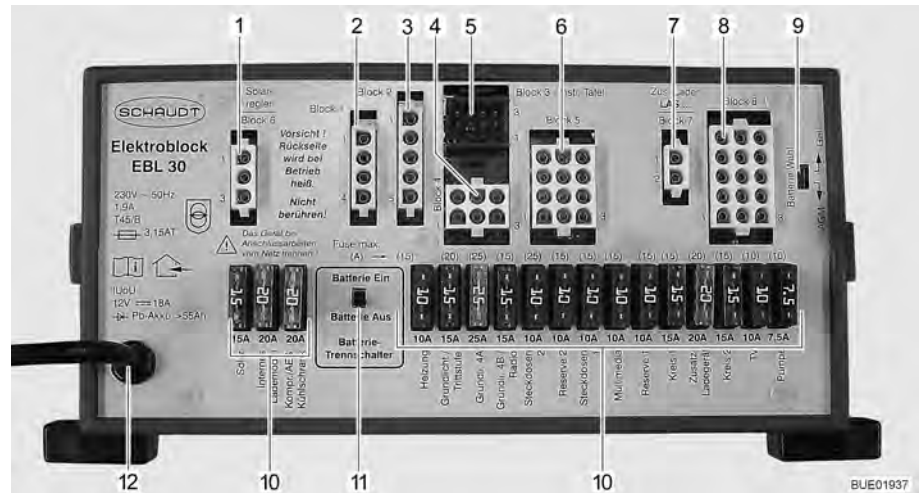

Fig. 63 Transformer/rectifier (EBL 30)

- 1 Block 6: Solar charge regulator (if fitted)
- 2 Block 1: Refrigerator
- 3 Block 2: Refrigerator power supply D+, battery sensor/control lines
- 4 Block 4: Heating, basic light (lighting in the entrance area), entrance step
- 5 Block 3: Panel
- 6 Block 5: Reserve 2, sockets, basic light
- 7 Block 7: Auxiliary charging unit
- 8 Block 8: Appliances, TV, water pump, reserve 1, multimedia, sockets
- 9 Battery selector switch (Gel/AGM)
- 10 Fuses
- 11 Battery cut-off switch ("Batterie Ein/Aus" (battery On/Off))
- 12 Mains connection 240 V~

**Functions** The transformer/rectifier has the following functions:

- The transformer/rectifier charges the living area battery. The transformer/rectifier charges the starter battery with a float charge only.
- The transformer/rectifier monitors the voltage in the living area battery.
- The transformer/rectifier distributes the current to the 12 V circuits and secures them. Devices with a maximum of 10 A can be connected to the sockets.
- The transformer/rectifier provides connections for a solar charge regulator, an auxiliary charging unit, as well as other control and monitoring functions.
- When the vehicle engine is turned off, the transformer/rectifier separates the starter battery electrically from the living area battery. This prevents the 12 V living area appliances from discharging the starter battery.
- The battery cut-off switch in the transformer/rectifier separates all the appliances from the living area battery.

The transformer/rectifier only works in conjunction with a panel.

The power in the transformer/rectifier (maximum 18 A) is divided into charging current and current to the appliances. The charging current is always just the portion that is not being used by any appliances. If the current to the appliances exceeds the current available, then the living area battery is discharged.

**Position** See section 8.8.

### 8.4.1 Battery cut-off switch

The battery cut-off switch switches off **all** the appliances in the living area, even inactive ones. Even appliances such as the entrance step, basic lighting or the refrigerator will stop working. This prevents the living area battery from slowly discharging if the vehicle is not used for a longer period of time (e.g. temporary lay-up).

If the vehicle is connected to the 240 V power supply via the CEE socket outlet, the batteries are charged, even if the battery cut-off switch is switched off.

### 8.4.2 Battery selector switch



- ▶ If the battery selector switch is set incorrectly, there is the danger of the formation of detonating (oxy-hydrogen gas). Danger of explosion!



- ▷ Incorrect setting of the battery selector switch damages the living area battery.
- ▷ The factory settings of the battery selector switch must not be changed.

### 8.4.3 Battery monitor



- ▷ You must fully recharge a discharged living area battery as soon as possible.

The battery monitor in the transformer/rectifier monitors the voltage in the living area battery.

If the battery voltage falls below 10.5 V, the battery monitor in the transformer/rectifier switches off all the 12 V appliances.

*Measures:*

- Switch off all electrical appliances that are not absolutely essential at the corresponding switch.
- If necessary, use the 12 V main switch to switch the 12 V power supply back on for a short while. This is only possible, however, when the battery voltage is above 11 V. If the voltage is below this level, the 12 V power supply cannot be switched on again until the living area battery has been recharged.

### 8.4.4 Charging the battery

When the vehicle engine is running, a relay in the transformer/rectifier alternator switches on the living area battery and the starter battery together and recharges them with the vehicle generator. When the vehicle engine is switched off, the batteries are automatically disconnected from one another again by the transformer/rectifier. This prevents the starter battery from being run down by electrical appliances in the living area. The starting capability of the vehicle is thus preserved. The terminal voltage of the living area battery or the starter battery can be read on the panel.

If the vehicle is connected to the 240 V power supply via the CEE socket outlet, the living area battery and the starter battery are charged by the charger module on the transformer/rectifier. The starter battery is only charged with a float charge. The charging current is adapted to suit the charging condition of the battery. This ensures that it is not possible to overload the battery.

To make use of the maximum output from the charger module on the transformer/rectifier, switch off all electrical appliances during charging.

**8.4.5 Retrofitting additional 12 V appliances**

The electrical system in the living area of the vehicle can have additional appliances added. The optional devices are to be connected to the reserve outputs on the transformer. The output of the optional devices may not exceed the rating of the fuse (e.g. 15 A). Do not use fuses on the transformer/rectifier that are higher than those stated on the transformer/rectifier.

**8.5 Panel (LT 453)**



Fig. 64 Panel (LT 453)

- 1 12 V main switch and green LED
- 2 Water pump switch and yellow LED
- 3 Mains connection symbol and yellow LED
- 4 Button to query the voltage of the living area battery
- 5 Button to query the fill level in the fresh water tank
- 6 Button to query the fill level in the waste water tank
- 7 Button to query the voltage of the starter battery
- 8 LED array to display the tank fill level
- 9 LED array to display the battery voltage

The switches and push buttons of the panel are sensor touchpads. The switching function is triggered by touching.

**Mains connection**

The yellow LED at the mains connection symbol  (Fig. 64,3) is lit when the vehicle is connected to an external mains supply. In this case, the LED will also be lit when the panel is switched off.

### 8.5.1 12 V main switch

The 12 V main switch (Fig. 64,1) switches the panel and the 12 V power supply of the living area on and off.

Exception: Depending on the model, refrigerator, heater, basic light (lighting in the entrance area), and entrance step remain ready to operate.

Switching on:

- Press switch "☺" (Fig. 64,1): The 12 V living area power supply is switched on. The LED lights up green.

Switching off:

- Press switch "☺" (Fig. 64,1) again: The 12 V living area power supply is switched off. The LED goes out.



- ▷ When leaving the vehicle, switch off the main 12 V power supply at the panel. This prevents any unnecessary discharge of the living area battery.
- ▷ Appliances, such as control units (e.g. solar charge regulator, defroster or panel) or fitted appliances (e.g. heating, refrigerator or step) continue to take power from the battery capacity, even if the 12 V power supply on the panel is switched off. Therefore disconnect the living area battery from the 12 V power supply via the switch on the transformer/rectifier if the vehicle will not be used for a long period of time.

### 8.5.2 Water pump switch

The water pump switch (Fig. 64,2) switches the power supply of the water pump on and off.

Switching on:

- Press the water pump switch "☹" (Fig. 64,2): The power supply of the water pump is switched on. The LED lights up yellow. The water pump is activated when opening a water tap.

Switching off:

- Press water pump switch "☹" (Fig. 64,2) again: The power supply of the water pump is switched off. The LED goes out.

### 8.5.3 LED array for battery voltage

The LED array (Fig. 64,9) displays the battery voltage of the starter battery or of the living area battery as follows:

- All LEDs light up: battery is sufficiently charged.
- Yellow and red LEDs are lit: battery is partly discharged (below 12.4 V).
- Only red LEDs are lit: battery is empty (below 11.5 V).

Displaying the battery voltage:

- Press "☺" button (Fig. 64,4): The battery voltage of the living area battery is displayed.
- Press "☹" button (Fig. 64,7): The battery voltage of the starter battery is displayed.

The following tables will help you correctly interpret the battery voltage of the living area battery displayed on the panel.

Battery voltage (values during operation)	Mobile operation (vehicle moving, no mains connection)	Battery operation (vehicle stationary, no mains connection)	Power operation (vehicle stationary, mains connection)
11.5 V or less Danger of total discharge (battery alarm)	12 V power supply overload	If appliances are switched off: Battery flat	12 V power supply overload
	The battery is not charged by the alternator	If appliances are switched on: Battery overload	The battery is not charged by the transformer/rectifier, the transformer/rectifier is defective
12.2 V up to 12.7 V	12 V power supply overload <sup>1)</sup>	Normal range	12 V power supply overload <sup>1)</sup>
	The battery is not charged by the alternator <sup>1)</sup>		The battery is not charged by the transformer/rectifier, the transformer/rectifier is defective <sup>1)</sup>
13.5 V	Battery being charged	Occurs only briefly after charging	Battery being charged

<sup>1)</sup> If the voltage does not exceed this range for several hours.

Values for off-load voltage	Charging condition of the battery <sup>1)</sup>
Less than 12 V	Discharge or totally discharge
12.2 V	25 %
12.7 V	50 %
More than 12.7 V	100 %

<sup>1)</sup> Guide values for dryfill battery.



▷ Total discharge causes irreparable damage to the battery.

*Measures:*

- When the battery alarm comes on, switch off the appliances and charge the living area battery, either by mobile operation or by connection to a 240 V power supply.

### 8.5.4 LED array for tank fill level

The LED array (Fig. 64,8) displays the fill level of the fresh water tank or of the waste water tank.

*Display fill level:*

- Press "☰" button (Fig. 64,5): The fill level of the fresh water tank is displayed by lit LEDs.
- Press "☷" button (Fig. 64,6): The fill level of the waste water tank is displayed by lit LEDs.

**Level indicator**

LED indicator	Tank fill level
All LEDs light up	Full tank
6 LEDs light up	Tank approx. 3/4 full
4 LEDs light up	Tank approx. 1/2 full
2 LEDs light up	Tank approx. 1/4 full
No LED lights up	Tank empty



▷ Further information can be obtained in the manufacturer's instruction manual.

### 8.6 240 V power supply



- ▶ Only allow qualified personnel to work on the electrical system.
- ▶ Have the vehicle's electrical system checked by a qualified electrician at least once every 3 years. If the vehicle is used frequently, an annual check is recommended.

The 240 V power supply provides electricity for:

- sockets with earth contact for appliances with maximum 16 A
- refrigerator
- transformer/rectifier

The electrical appliances connected to the 12 V power supply of the living area are supplied with voltage by the living area battery.

Connect the vehicle to an external 240 V power supply system as often as possible. The charger module in the transformer/rectifier automatically charges the living area battery. In addition to this, the starter battery is charged with a float charge of 2 A.



**8.6.1 240 V connection (CEE socket outlet)**



▷ Overvoltage can damage connected devices. Overvoltage can be caused by lightning, irregular voltage sources (e.g. petrol-operated generators) or power connections on ferries for example.

**Requirements concerning the 240 V connection**

- The connecting cable, the plug connectors at the point of supply and the plug connector to the vehicle must comply with IEC 60309. The standard designation for the plug connectors is "CEE blue".
- Use H07RN-F rubber sheathed cable with a minimum cable cross-section of 2.5 mm<sup>2</sup> and a maximum length of 25 m.
- Earth contact connectors (safety) are not permitted. The interconnection of CEE/safety adapters is also prohibited.

**8.6.2 Connecting the 240 V power supply**



- ▶ The external 240 V power supply must be protected by fuse with a fault current protection switch (FI-switch, 30 mA).
- ▶ To prevent overheating, the cable must be fully uncoiled from the cable reel.
- ▶ In case of doubt or if the 240 V supply is not available or is faulty, contact the operator of the power supply device.



- ▷ The 240 V connection in the vehicle is equipped with a fault current protection switch (FI-switch).
- ▷ For the connection points on camp sites (camping distributors) fault current protection switches (FI-switches, 30 mA) are obligatory.

The vehicle can be connected to an external 240 V power supply. As a principle, only use the 240 V connection on the vehicle (CEE socket outlet) for connecting.



Fig. 65 Safety cut-out and FI-switch (240 V fuse box)



Fig. 66 240 V connection on the vehicle (CEE socket outlet)



- ▷ The second safety cut-out (Fig. 65,2) is optional. Whether this safety cut-out is present or not depends on the equipment of the vehicle.

*Connecting the vehicle:*

- Check whether the power supply device is suitable regarding connection, voltage, frequency and current.
- Check whether the cables and connections are suitable.
- Check the plug connectors and cables for visible damage.

- Switch off both safety cut-outs (Fig. 65,1 and Fig. 65,2) in the fuse box (Fig. 65,3).
- Open the cover of the 240 V connection on the vehicle (Fig. 66) and insert the plug connector. Ensure that the detent of the spring-mounted pivoting cover is engaged in position.
- Plug the connector of the connecting cable into the socket of the camping distributor. Ensure that the detent of the spring-mounted flap is also engaged here.
- Switch on both safety cut-outs in the fuse box.

*Checking the fault current protection switch:*

- When the vehicle is connected to the 240 V supply, press the test button (Fig. 65,5) of the fault current protection switch (FI-switch) (Fig. 65,4) in the fuse box (Fig. 65,3). The fault current protection switch must trip.
- Switch the fault current protection switch (Fig. 65,4) back on again.

*Unplugging the connection:*

- Switch off both safety cut-outs (Fig. 65,1 and 2) in the fuse box (Fig. 65,3).
- Loosen the detent on the camping distributor and unplug the connecting cable from the socket.
- Loosen the detent on the vehicle, unplug the plug connector and close the cover of the 240 V connection.

### 8.7 Fuses



- ▶ Only replace defective fuses when the cause of the defect is known and has been remedied.
- ▶ Replace defective fuses only after the power supply has been turned off.
- ▶ Never bridge or repair fuses.
- ▶ Only replace faulty fuses with a new fuse with the same rating.

#### 8.7.1 12 V fuses

The appliances connected to the 12 V power supply in the living area are fused individually. The fuses are accessible at different positions in the vehicle.

Before changing fuses, take the function, value and colour of the relevant fuses from the following specifications. When changing fuses, only use flat fuses with the values shown below.

#### Fuses on the starter battery

The fuses are installed in the vicinity of the starter battery.

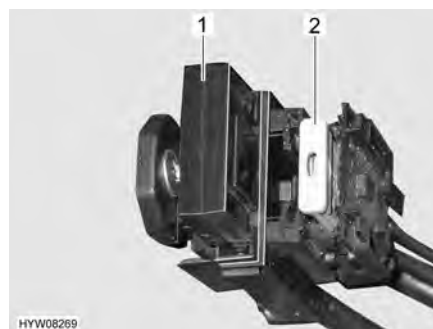

- 1 Jumbo flat fuse 40 A/orange (for the transformer/rectifier)
- 2 Flat fuse 15 A/blue (for refrigerator and charging line)

Fig. 67 Fuses (starter battery)

**Fuses on the living area battery**

The fuses are installed in the vicinity of the living area battery.



- 1 Jumbo flat fuse 40 A/orange (for the transformer/rectifier)
- 2 Flat fuse 2 A/grey (for battery sensor, living area battery)
- 3 Flat fuse 20 A/yellow (for special equipment: heating)
- 4 Flat fuse 15 A/blue (for special equipment: heating switch)

Fig. 68 Fuses (living area battery)

**Fuses on the relay box AD01**

For the position of the relay box AD01 see section 8.8.

FuNo	Function	Value/colour
B2	Cl. 15 (ignition on)	15 A blue
B3	Cl. 30 (constant positive)	15 A blue
B5	Signal D+	Internal Polyswitch (2 A)
B6	Spare (additional heater)	15 A blue
B7	Lamps	5 A light brown

**Fuse for the Thetford toilet (swivel toilet)**

The toilet has a maintenance-free fuse which resets automatically.

**Fuses on the transformer/rectifier EBL 30**

Function	Value/colour
Solar charger module	15 A blue
Internal charger module	20 A yellow
Refrigerator	20 A yellow
Heater	10 A red
Basic light/entrance step/awning light	15 A blue
Basic light	25 A white
Basic light/radio	15 A blue
12 V sockets, USB charging socket	10 A red
Spare 2, electric pull-down bed	10 A red
12 V sockets, USB charging socket	10 A red
Multimedia	10 A red
Spare 1	10 A red
Circuit 1 (light 1)	15 A blue
Auxiliary charging unit	20 A yellow
Circuit 2 (light 2, waste water tank drainage)	15 A blue
TV	10 A red
Water pump	7.5 A brown

**8.7.2 240 V fuse**



- ▷ Check the fault current protection switch for each connection to the 240 V power supply, at least once every 6 months.



Fig. 69 Safety cut-out and FI-switch (240 V fuse box)

A fault current protection switch (FI-switch) (Fig. 69,3) in the fuse box protects the complete vehicle from fault current (30 mA).

The downstream safety cut-out (10 A) (Fig. 69,1) secures the 240 V sockets, the transformer/rectifier, the auxiliary charging unit and the refrigerator.

For vehicles with special equipment, e.g. roof air conditioning unit, the device is protected by an additional safety cut-out (16 A) (Fig. 69,2).

**Position** See section 8.8.

*Checking the fault current protection switch:*

- When the vehicle is connected to the 240 V power supply, press the test button (Fig. 69,4). The fault current protection switch (FI-switch) must be activated.

**8.8 Position of the electric components**

	<b>Sacramento / Yosemite / Serengeti / Sierra Nevada / Grand Canyon / Yellowstone / Ayers Rock (Fiat base vehicle)</b>	<b>Grand Canyon S / Redwood S (Mercedes-Benz base vehicle)</b>
<b>Starter battery</b>	In the footwell of the driver's cabin underneath a floor plate	In the footwell of the driver's cabin underneath a floor plate
<b>Living area battery</b>	Underneath right-hand seat console	Underneath left-hand bedding box, behind a panel
<b>Transformer/rectifier</b>	Underneath left-hand seat console	Underneath left-hand bedding box, behind a panel
<b>Fuse box</b>	In bench, accessible through flap on the bench's side	Underneath left-hand bedding box, behind a panel
<b>Relay box AD01</b>	In bench, accessible through flap on the bench's side	-

**8.9 Circuit diagrams**

**8.9.1 Block diagram 240 V**

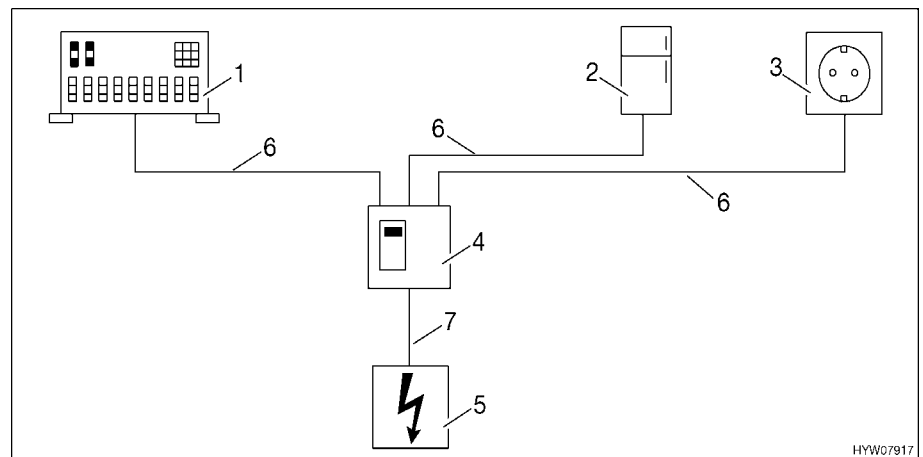

Fig. 70 240 V circuit diagram

- 1 Transformer/rectifier
- 2 Refrigerator
- 3 Sockets
- 4 Automatic circuit breaker
- 5 240 V connection
- 6 H05VV-F3G1,5<sup>2</sup>bu/bn/gnye
- 7 3G2,5<sup>2</sup>

Fig. 70 shows a schematic diagram of the 240 V network.

8.9.2 Block diagram 12 V

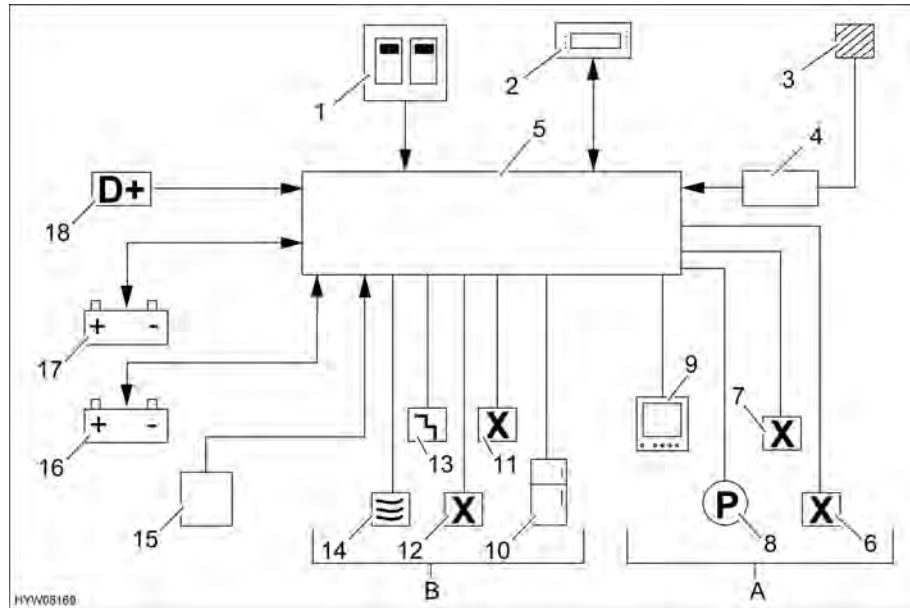

Fig. 71 12 V circuit diagram

1	240 V automatic circuit breaker
2	Panel with 12 V main switch
3	Solar
4	Solar regulator
5	Transformer/rectifier with battery cut off switch
<b>A</b>	<b>Light, consumer circuits can be switched on/off via 12 V main switch</b>
6	Sockets 1, sockets 2, spare 1, 2
7	Circuit 1, circuit 2
8	Pump (water pump)
9	Multimedia/TV
<b>B</b>	<b>Basic supply can be switched on/off via battery cut-off switch</b>
10	Refrigerator
11	Basic light 4A (special equipment, e.g. defroster)
12	Basic light 4B/radio
13	Basic light, step
14	Heater
15	Auxiliary charging unit
16	Living area battery
17	Starter battery
18	(D+)

Fig. 71 shows a schematic diagram of the 12 V network.

## Chapter overview

This chapter contains instructions regarding the appliances of the vehicle. The instructions refer exclusively to the operation of the appliances. Further information about the appliances can be found in the instruction manuals for the appliances, included separately with the vehicle.

### 9.1 General



- ▷ The heat exchanger of the Truma hot-air heater has to be replaced after 30 years. Only the manufacturer of the heater or an authorised specialist workshop is allowed to replace the heat exchanger. The operator of the heater must see to it that the parts are replaced.
- ▷ For safety reasons, spare parts for pieces of heating appliances must correspond with manufacturer's instructions and be permitted by the manufacturer as a spare part. These spare parts may only be fitted by the manufacturer or an authorised specialist workshop.



- ▷ Further information can be obtained in the instruction manual for the respective appliance.

The heater, boiler, cooker and refrigerator are fitted depending on the model of the vehicle.

In this instruction manual a description is given only for the operation of the appliances and their particular features.

To operate gas appliances, first open the regulator tap on the gas bottle and the gas isolator tap corresponding to the appliance.

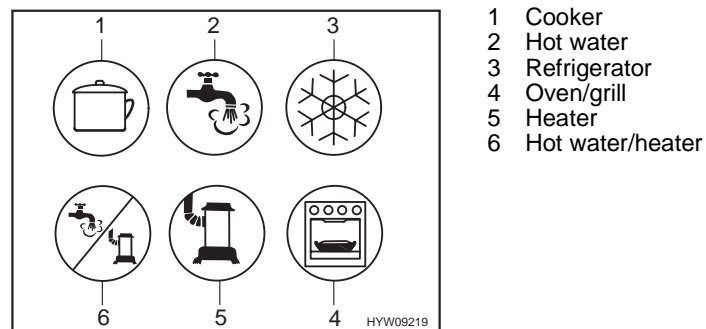

Fig. 72 Possible symbols for the gas isolator taps

### 9.2 Heater and boiler

The heater can both heat up the vehicle interior (heating the room air) and heat up the domestic water (boiler function). The following instructions are also valid if the heater is only used as boiler.



- ▶ Never let gas escape unburned due to danger of explosion.
- ▶ Never run the heater in gas operation when refuelling, on ferries or in the garage. Danger of explosion!
- ▶ Never operate the heater in gas operation in closed spaces (e.g. garages). Danger of poisoning and suffocation!
- ▶ The waste gas vent may neither be closed nor blocked.



- ▶ Do not use the space behind the heater as a storage compartment.
- ▶ The water in the boiler can be heated up to 65 °C. Risk of scalding!



- ▷ Never use boiler when empty.
- ▷ If the boiler is not being used, empty it if there is any risk of frost.
- ▷ Only operate the boiler with the maximum temperature setting if you require a large quantity of warm water. This protects the boiler against the build-up of limescale.



- ▷ Do not use the water from the boiler as drinking water.
- ▷ If the power supply to the heater was interrupted, the time must be reset.

**Initial start-up**

When lighting the heater for the first time a small amount of smoke and odour will occur. Immediately set the operating switch of the heater to its highest position. Open doors and windows and ventilate well. Smoke and odour will disappear by themselves after a while.

**9.2.1 To heat properly**



Fig. 73 Air outlet nozzle (hot-air heater)

**Hot air distribution**

Several air outlet nozzles (Fig. 73) are built into the vehicle. Pipes conduct the warm air to the air outlet nozzles. Turn the air outlet nozzles in a suitable position so the air can escape as required. To avoid draft close the air outlet nozzles on the dashboard and set the air distribution of the base vehicle to air circulation.

**Adjusting the air outlet nozzles**

- Fully open: Full hot air stream
- Half or partially open: Reduced hot air stream

When five air outlet nozzles are completely opened, less warm air escapes through each nozzle. However, if only three air outlet nozzles are opened, more warm air flows out of each nozzle.



**9.2.2 Hot-air heater and boiler with CP plus digital operating unit**



- ▷ If there is a risk of frost and the heater is not in operation, empty the boiler.
- ▷ The circulation fan is automatically switched on when the hot-air heater is activated, and it stays on. This puts an immense strain on the living area battery, if the vehicle is not connected to an external 240 V power supply. Take into consideration that the living area battery only has limited reserves of energy.



- ▷ The hot-air heater can even run on an empty boiler.
- ▷ If the power supply to the heater was interrupted, the time must be reset.

**Operating unit**

The operating unit is divided into two sections:

- Display
- Operating buttons



- 1 Display
- 2 Rotary push button
- 3 Back button

Fig. 74 Operating unit (hot-air heater and boiler)

After being switched on, the most recently set values/operating parameters are activated.

If no button is pressed, the operating unit switches to stand-by mode after a few minutes.

If the time is set, the display in stand-by mode alternates between the time and the room temperature set.

After being switched off, the display in the control unit may remain active for several minutes since the heater is still running.

**Operating buttons**

The operating buttons have the following functions:

Button	Button operation	Function
Rotary push button (Fig. 74,2)	Turn to the right	Menu is run through from left to right Values are increased
	Turn to the left	Menu is run through from right to left Values are decreased
	Press briefly	Selected value is saved Menu item is selected for changing values (selected menu item flashes)
	Press (3 seconds)	Switch on or switch off
Back button (Fig. 74,3)	Press	Return from a menu item without saving values

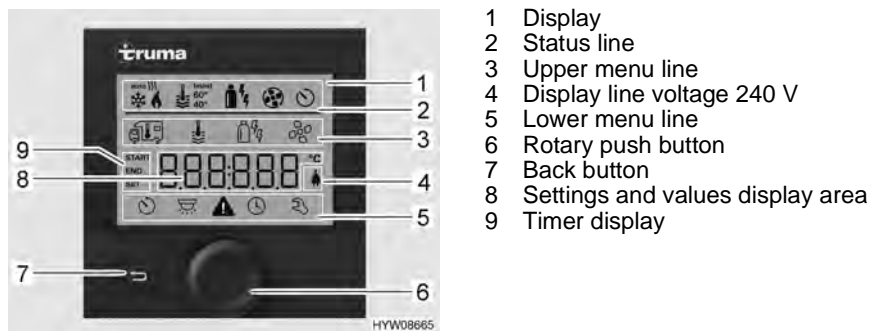

Fig. 75 Operating unit with displays

**Display** The display is divided into four sections:

- Status line (Fig. 75,2)
- Upper menu line (Fig. 75,3)
- Display area (Fig. 75,8)
- Lower menu line (Fig. 75,5)

*Switching operating unit on/off:*

- Press and hold the rotary push button (Fig. 75,6) for approx. 3 seconds. Both menu lines (Fig. 75,3 and Fig. 75,5) are displayed. The first symbol flashes.
- ▷ Switching the operating mode on/off means switching between stand-by and setting mode. In stand-by mode, the display alternates between the room temperature and the time that have been set.



*Carrying out settings:*

- Turn rotary push button (Fig. 75,6) until the required menu symbol flashes.
- Press rotary push button.
- Turn rotary push button until the required value is displayed.
- Press rotary push button to save the value set. If you do not wish to change the value originally set: Press back button (Fig. 75,7).

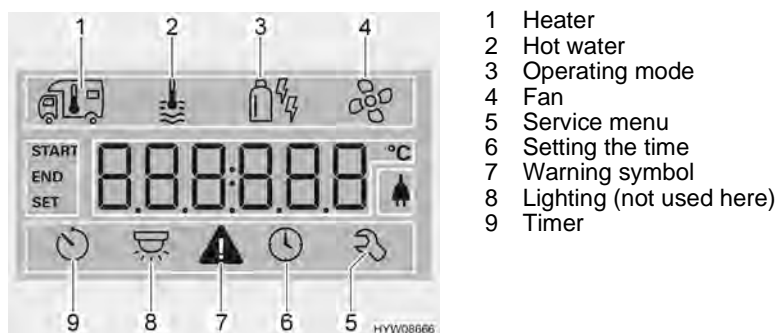

Fig. 76 Display (operating unit)

*Switching on the heater:*

- Open the regulator tap on the gas bottle and the gas isolator tap "Heater/boiler".
- Turn rotary push button (Fig. 75,6) until the heater menu symbol (Fig. 76,1) flashes.
- Press rotary push button.
- Turn rotary push button until required value is displayed.
- Press rotary push button to save the value set. The symbol in the status line (Fig. 75,2) flashes until the room temperature set is reached. If you do not wish to change the value originally set: Press back button (Fig. 75,7).

*Switching off the heater:*



- Turn temperature value back until OFF is displayed. Press rotary push button to save.
- ▷ The required room temperature can also be changed in stand-by mode by turning the rotary push button.

*Switching on hot water production:*

- Open the regulator tap on the gas bottle and the gas isolator tap "Heater/boiler".
- Turn rotary push button (Fig. 75,6) until the hot water menu symbol (Fig. 76,2) flashes.
- Press rotary push button.
- Turn rotary push button until the required value is displayed:
  - OFF: Hot water production is switched off.
  - 40°: Hot water is heated to 40 °C.
  - 60°: Hot water is heated to 60 °C.
  - BOOST: Fast heating of hot water (boiler priority) for max. 40 minutes. The water temperature is then held at a higher level for two reheating cycles (approximately 62 °C).
- Press rotary push button to save the value set. The symbol in the status line (Fig. 75,2) flashes until the hot water temperature set is reached. If you do not wish to change the value originally set: Press back button (Fig. 75,7).

*Switching off hot water production:*

- Turn rotary push button until OFF is displayed. Press rotary push button to save.

**Safety/drainage valve**

The boiler is equipped with a safety/drainage valve (Fig. 77). The safety/drainage valve prevents water in the boiler from freezing, when there is frost and the heater is not switched on.



- ▷ When the vehicle is not used for a long period of time, open the safety/drainage valve and empty the boiler.
- ▷ At temperatures below 2 °C the safety/drainage valve opens automatically. Only if the temperature of the safety/drainage valve lies above 6 °C can it be shut again.
- ▷ The water pump and the water fittings are not protected against freezing by the safety/drainage valve.



- ▷ The drainage neck of the safety/drainage valve has to be free of dirt (e.g. leaves, ice) at all times.

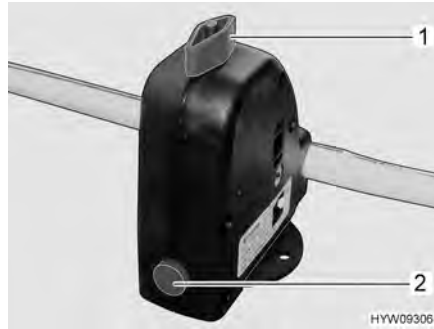

Fig. 77 Safety/drainage valve (boiler)

**Position** Position of the safety/drainage valve, see section 10.6.

**Filling/emptying the boiler** The boiler can be supplied with water from the water tank.

*Filling the boiler with water:*





- Switch on the 12 V power supply on the panel.
- Close the safety/drainage valve. Turn the knob (Fig. 77,1) perpendicular to the safety/drainage valve and push the push button (Fig. 77,2) in.
- Set all the water taps to "Hot" and open them. The water pump is turned on. The warm water pipes are filled with water.
- Keep the water taps open until the water flowing out of the water taps has no bubbles in it. This is the only way to ensure that the boiler is full of water.
- Close all water taps.

*Emptying the boiler:*

- Switch off hot water production.
- Open the safety/drainage valve. To do this turn the knob (Fig. 77,1) parallel to the safety/drainage valve. The push button (Fig. 77,2) jumps out. The boiler is drained to the outside by the safety/drainage valve.
- Check whether the water has been drained completely from the boiler (approx. 10 litres).

**Operating modes** The hot-water heater with the boiler can be operated with various energy sources.

*Selecting operating mode:*

- Turn rotary push button (Fig. 75,6) until the menu symbol operating mode (Fig. 76,3) flashes.
- Press rotary push button.
- Turn rotary push button until the desired operating mode is displayed:
  -  Gas operation
  -  Electrical operation (900 W)
  -  Electrical operation (1800 W)
  -  Gas and electrical operation (900 W)
  -  Gas and electrical operation (1800 W)
- Press the rotary push button to save the set operating mode. To revert to the original setting: Press back button (Fig. 75,7).



- ▷ 240 V electrical operation is only possible when the vehicle is connected to the 240 V power supply.
- ▷ Select the output level for 240 V electrical operation so that it corresponds to the fuse protection of the 240 V connection (900 W for 3.9 A fuse, 1800 W for 7.8 A fuse).

The combination of gas operation and 240 V electrical operation shortens the time required to heat up the vehicle.

#### Setting the fan:

- Turn rotary push button (Fig. 75,6) until the fan menu symbol (Fig. 76,4) flashes.
- Press rotary push button.
- Turn rotary push button until the required value is displayed:
  - OFF: Fan is switched off.
  - VENT: Air circulation
  - ECO: Low fan setting
  - HIGH: High fan setting
  - BOOST: Fast room heating. Boost is available if the current room temperature is at least 10 °C below the selected room temperature.
- Press rotary push button to save the value set. If you do not wish to change the value originally set: Press back button (Fig. 75,7).

#### Setting the timer:

- Turn rotary push button (Fig. 75,6) until the timer menu symbol (Fig. 76,9) flashes.
- Press rotary push button. The start time is displayed and the hour display flashes.
- Turn rotary push button until the hour of the selected start time is displayed.
- Press rotary push button. The minute display flashes.
- Turn rotary push button until the minute of the selected start time is displayed.
- Press rotary push button.
- Proceed in the same way to set the switch-off time, the required room temperature, the hot water setting and the fan setting.
- Press rotary push button. The timer is activated. The timer symbol (Fig. 76,9) flashes when the timer is programmed and active.



- ▷ The service menu contains items that generally only need to be set once (language, background brightness, calibration), as well as information for service centres (version numbers).

#### Fault display

The warning symbol (Fig. 76,7) flashes in the event of a warning. The heater continues to operate. In the event of only a temporary fault, the warning symbol goes out automatically.

In the event of a warning, the control unit displays the error code for the fault. The heater is switched off. Press rotary push button to restart the heater.



- ▷ Further information can be obtained in the manufacturer's instruction manual.

### 9.2.3 Wall flue

Fresh air and exhaust gases of the heater system are conducted in a two-chamber wall flue.



- ▷ Park the vehicle such that the wall flue gets enough fresh air.
- ▷ The wall flue must be free at all times. Do not cover the wall flue.
- ▷ When camping in winter, maintain wall flue free of snow and ice.
- ▷ Check the wall flue periodically depending on the weather (snow, leaf fall, dirt, etc.). If necessary, clean the wall flue.
- ▷ When washing the vehicle do not aim the water jet directly at the wall flue.
- ▷ When disregarding this, the flawless operation of the heater can not be guaranteed.



Fig. 78 Wall flue (hot-air heater)

The wall flue is mounted on the left side wall.

### 9.2.4 Eberspächer hot-air heater



- ▶ Take the device out of operation by removing the fuse and contact customer service if one of the following events occurs: Long-lasting, strong development of smoke; unusual combustion noises; smell of fuel; smell of overheated electrical components; continuous fault shut-down.
- ▶ Do not switch the appliance off and back on again more frequently than twice in quick succession. If the appliance is switched off and back on again frequently within a short time, too much fuel can accumulate and an explosion can occur.



- ▷ The heater is powered with diesel fuel from the fuel tank of the base vehicle. The heater is not approved for operation with fuels of Class L (heating oil).
- ▷ Operate the heater every 4 weeks for approx. 10 minutes in order to prevent a blockage of moving parts.



- ▷ Before spending a longer period (e.g. winter camping) at elevations above 1,500 m, a service centre must adapt the heater to the conditions prevalent at higher altitudes.
- ▷ The heater can also be operated in pure fan mode (without heating).



- 1 Operating unit
- 2 Status line
- 3 Control button, forwards
- 4 Confirm button
- 5 Cancel button
- 6 Display line
- 7 Control button, backwards

Fig. 79 Operating unit (hot-air heater)

**Operating unit**

The heater is controlled via the operating unit (Fig. 79,1) in side the vehicle. The operating unit is divided into two sections:

- Display
- Operating buttons

**Operating buttons**

The control buttons have the following function:

Pos. in Fig. 79	Button	Function
4		<ul style="list-style-type: none"> <li>● Switching on</li> <li>● Confirming a selected function</li> </ul>
5		<ul style="list-style-type: none"> <li>● Cancelling a setting</li> <li>● Ending a function</li> </ul>
3		<ul style="list-style-type: none"> <li>● Selecting a function in the menu line</li> <li>● Changing a value</li> </ul>
7		<ul style="list-style-type: none"> <li>● Selecting a function in the menu line</li> <li>● Changing a value</li> </ul>

**Menu line**

The following functions can be selected via the status line (Fig. 79,2):

Symbol	Signification
	Switching the heating on/off
	Switching the fan on/off
AD	Switching optional device on/off (depending on configuration)
P	Program/preselection
	Settings

**Display line**

The display line (Fig. 79,6) shows figures and texts. It is possible to choose between the following displays:

- Time
- Temperature
- Operating time

**Status line** The status line (Fig. 79,2) indicates which functions have been activated:

- Heating operation active
- Fan operation active
- Optional device active (depending on configuration)

*Switching on the heater:*

- Press the button (Fig. 79,4) on the operating unit (Fig. 79,1) until the heating mode symbol appears on the display.



- ▷ After switching on, "On" will appear for 2 seconds on the display. Then, the remaining operation time or "∞" will be displayed.

*Switching off the heater:*

- Press the button (Fig. 79,5) on the operating unit (Fig. 79,1) until the heating mode symbol goes out on the display.



- ▷ To cool the heater, the circulation fan continues to coast for approx. 4 minutes after the heater is switched off.
- ▷ Further information can be obtained in the manufacturer's instruction manual.

### 9.3 Dometic FreshLight air conditioning unit



- ▶ Do not operate the air conditioning unit near to flammable liquids or in closed rooms.
- ▶ Do not store or install flammable objects in the vicinity of the air outlet. The clearance must be at least 50 cm.
- ▶ Do not reach into the ventilation outlets.
- ▶ Use only fire extinguishers in the event of a fire. Do not use water to extinguish a fire!
- ▶ Only operate the air conditioning unit if the housing and the lines are undamaged.



- ▷ Do not clean vehicle in car wash.



- ▷ Also read the manufacturer's instruction manual.



**Remote control** The air conditioning unit can be switched on and off (from stand-by mode) with the remote control. The remote control can be used to control all functions apart from air distribution.

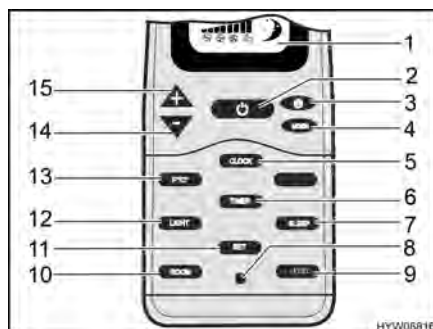

Fig. 80 Remote control (air conditioning unit)

- 1 Digital display
- 2 On/Off button
- 3 Fan stage button
- 4 "MODE" button
- 5 "CLOCK" button
- 6 "TIMER" button
- 7 "SLEEP" button
- 8 Reset button
- 9 I FEEL auxiliary function button
- 10 Interior temperature display button "ROOM"
- 11 "SET" button
- 12 "LIGHT" button
- 13 Temperature unit button (°F/°C)
- 14 Temperature decrease button (-)
- 15 Temperature increase button (+)

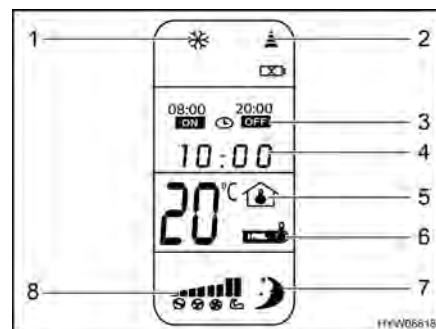

Fig. 81 Digital display (remote control)

- 1 Mode symbol
- 2 Send data symbol
- 3 Timer function display
- 4 Time display
- 5 Internal temperature display
- 6 "I FEEL" auxiliary function symbol
- 7 Sleep function symbol
- 8 Fan stage display

The air conditioning unit can be operated in the following modes:

Operating mode	Symbol	Function
Automatic		The air conditioning unit heats or cools until the set internal temperature is reached, and automatically selects the required fan stage
Cooling		The air conditioning unit cools with the set fan stage until the set internal temperature is reached
Heating		The air conditioning unit heats with the set fan stage until the set internal temperature is reached
Air circulation		The air conditioning unit blows air into the interior
Venting		The air conditioning unit blows used air out of the interior and to the outside
Dehumidification		The air conditioning unit heats or cools until the set internal temperature is reached, and automatically selects the required fan stage and circulation mode



- ▷ If the air conditioning unit is to be switched to "venting", both blinds on the sunroof must be opened fully.
- ▷ In "venting" mode, the fan does not start until the ventilation flap is open. This can take a few minutes.
- ▷ After "heating" mode is activated, the air conditioning unit does not start until after approx. 30 seconds.

**Ceiling unit**

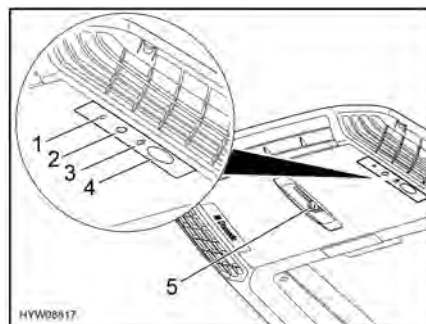

- 1 Operating status display
- 2 On/Off button
- 3 Lighting button
- 4 Infrared receiver
- 5 Sliding regulator for air flow

Fig. 82 Ceiling unit



- ▷ After switching on, the air conditioning unit starts with the settings that were set most recently.

*Switching on:*

- Press the On/Off button (Fig. 82,2) on the ceiling unit. Pressing briefly switches the unit to stand-by mode, pressing for longer switches the air conditioning unit on.
- When the air conditioning unit is in stand-by mode: Press the On/Off button (Fig. 80,2) on the remote control.

*Switching off:*

- Press the On/Off button (Fig. 80,2) on the remote control. Air conditioning unit changes to stand-by mode.
- Press the On/Off button (Fig. 82,2) on the ceiling unit. The air conditioning unit is switched off.

**LED**

The LED (Fig. 82,1) on the ceiling unit (Fig. 82) displays the operating status of the air conditioning unit:

Status LED	Signification
Off	Air conditioning unit off
Orange	Air conditioning unit ready for operation (stand-by mode)
Green	Air conditioning unit in operation
Green (flashing)	Air conditioning unit switches to "Heating" mode or is defrosted
Red	No 240 V power present
Red (flashing slowly)	Fault in the interior temperature gauge
Red (flashing quickly)	Fault in the exterior temperature gauge

**Lighting** The lights on the air conditioning unit are dimmable. When it is switched on, the lights are switched on at the last set brightness level.

*Switching the lights on/off:* ■ Briefly press the lighting button (Fig. 82,3).

*Dimming the lights:* ■ Press the lighting button until the lights have dimmed to the desired brightness.  
 ■ To increase the brightness of the lights again: Release the lighting button briefly then press it again.

**Air current** The air current can be directed in different directions. The distribution of the air current toward the front or back is continuously adjustable.

*Adjusting air current:* ■ Move the fins on the ceiling unit's front air outlet into the desired position.  
 ■ Rotate the knob (Fig. 82,5) on the sliding regulator anticlockwise. The sliding regulator for air distribution is released.  
 ■ Slide the sliding regulator forwards or backwards to the desired position. The side to which the sliding regulator is pushed is closed.  
 ■ Turn the knob tight in the clockwise direction.

**Blind** The amount of sunlight and light incidence can be adjusted with two blinds on the air conditioning unit sunroof.



▷ When the vehicle is standing in bright sunlight, the blind must not be completely closed. This can cause a heat build-up. To prevent material damage, the blind must remain at least one third open.

*Adjusting:* ■ Grip the blinds on the holding bar and push.

**Remote control** The air conditioning unit settings can be changed individually with the remote control. However, it is also possible to first enter different settings on the remote control and then send them collectively to the air conditioning unit.

*Sending a setting directly:* ■ Point the remote control's infrared transmitter at the infrared receiver (Fig. 82,4) on the ceiling unit.  
 ■ Press the desired button. The setting is applied directly and is confirmed with a signal tone.

*Sending settings combined:* ■ Point the remote control's infrared transmitter away from the ceiling unit.  
 ■ Enter the desired settings.  
 ■ Point the remote control's infrared transmitter at the infrared receiver (Fig. 82,4) on the ceiling unit.  
 ■ Press the send button (Fig. 80,11) on the remote control. The settings are sent collectively to the air conditioning unit and this is confirmed with a signal tone.

*Setting the time:* ■ Press the time button (Fig. 80,5) until the time display (Fig. 81,4) flashes.  
 ■ Use the "+" (Fig. 80,15) and "-" (Fig. 80,14) buttons to set the desired time.  
 ■ Press the send button. The time is saved.

- Timer** The timer function can be used to program a switch-on time, a switch-off time or both.
- Sleep function** If the sleep function is set, the selected temperature is automatically lowered after 1 hour and after 2 hours so as to ensure a pleasant sleeping temperature.
- I FEEL auxiliary function** If the "I FEEL" function is activated, the remote control measures the current temperature in its immediate proximity and sends this value to the air conditioning unit. The air conditioning unit delivers the set temperature at the remote control's location. The remote control must be pointed at the ceiling unit's infrared receiver.

### 9.4 Boiler



- ▶ Never let gas escape unburned due to danger of explosion.
- ▶ Never run the boiler in gas operation when refuelling, on ferries or in the garage. Danger of explosion!
- ▶ Never operate the boiler in gas operation in closed spaces (e.g. garages). Danger of poisoning and suffocation!
- ▶ The water in the boiler can be heated up to 65 °C or 70 °C. Risk of scalding!
- ▶ Remove cap from exterior chimney before using the boiler.



- ▷ Never use boiler when empty.
- ▷ If the boiler is not being used, empty it if there is any risk of frost.
- ▷ Only operate the boiler with the maximum temperature setting if you require a large quantity of warm water. This protects the boiler against the build-up of limescale.
- ▷ Switch on the boiler and empty it if the vehicle is not used.



- ▷ Do not use the water from the boiler as drinking water.

### 9.4.1 Truma boiler

**Operating modes**

Depending on the version, the boiler may be operated with gas and/or electrically.



Fig. 83 Control unit for gas operation (Truma boiler)

*Switching on gas operation:*

- Remove cap from waste gas vent.
- Open the regulator tap on the gas bottle.
- Open "Boiler" stop valve.
- Set the flip switch (Fig. 83,4) on "50 °C" (Fig. 83,1) or on "70 °C" (Fig. 83,3).

*Switching off gas operation:*

- Set the flip switch (Fig. 83,4) on "0" (Fig. 83,2).
- ▷ If there is a fault present, the indicator lamp (Fig. 83,5) will be lit red.



Fig. 84 Control unit for 240 V operation (Truma boiler)

*Switching the 240 V operation on:*

- Connect the vehicle to an external 240 V power supply.
- Switch on the 240 V automatic circuit breaker.
- Set the flip switch (Fig. 84,4) on low output (Fig. 84,1) or on high output (Fig. 84,3).

*Switching the 240 V operation off:*

- Set the flip switch (Fig. 84,4) on "0" (Fig. 84,2).
- ▷ If there is a fault present, the indicator lamp (Fig. 84,5) will be lit red.



*Switching combined operation on:*

- Set the flip switch (Fig. 83,4) on "50 °C" (Fig. 83,1) or on "70 °C" (Fig. 83,3).
- Set the flip switch (Fig. 84,4) on low output (Fig. 84,1) or on high output (Fig. 84,3).

*Switching combined operation off:*

- Set both flip switches (Fig. 83,4 and Fig. 84,4) on "0".



- ▷ If there is a fault present, the indicator lamps (Fig. 83,5 and Fig. 84,5) will be lit red.



Fig. 85 Drain cock (Truma boiler)

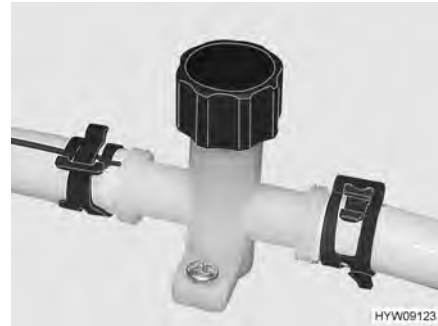

Fig. 86 Drain cock (water pipe)

### Position of drain cocks

The position of the drain cocks is specified in section 10.6.

### Filling/emptying the boiler

The boiler can be supplied with water from the water tank.

*Filling the boiler with water:*

- Close all drain cocks (Fig. 86 or Fig. 85).
- Set all the water taps to "Hot" and open them. The water pump is turned on. The warm water pipes are filled with water.
- Keep the water taps open until the water flowing out of the water taps has no bubbles in it. This is the only way to ensure that the boiler is full of water.
- Close all water taps.

*Emptying the boiler:*

- Set the flip switch for gas operation (Fig. 83,4) and/or the flip switch for 240 V operation (Fig. 84,4) to "0".
- Open all drain cocks (Fig. 85 or Fig. 86).
- Check whether the water has been drained completely from the boiler (approx. 10 litres).

## 9.5 Gas cooker



- ▶ During operation of the gas cooker, do not leave the gas cooker unattended. Even if the gas cooker cannot be overseen for only a short time (e.g. Visit to the toilet), switch the gas cooker off.
- ▶ Never let gas escape unburned due to danger of explosion.
- ▶ Before using the cooker make sure that there is sufficient ventilation. Open windows or the skylight.
- ▶ Do not use the gas cooker for heating purposes.
- ▶ Always protect your hands with cooking gloves or potholders when handling hot pots, pans and similar items. There is a risk of injury!



- ▶ During activation and operation of the gas cooker, no flammable objects or highly inflammable objects such as dishcloths, napkins etc. must be near the gas cooker. Fire hazard!
- ▶ The process of ignition must be visible from above and must not be covered by cooking pans placed on the cooker.
- ▶ The gas cooker lid is held closed by a spring. When closing there is danger of getting injured!



- ▷ Do not use the glass gas cooker cover as a hob.
- ▷ Do not close the gas cooker lid while the gas cooker is in operation.
- ▷ Do not apply pressure on the gas cooker lid when it is closed.
- ▷ Do not place hot cooking pans on the gas cooker lid.
- ▷ Keep the gas cooker lid open after cooking until the burners are cool. Otherwise the glass plate could shatter.



- ▷ Only use pots and pans whose diameter is appropriate for the gas cooker burners.
- ▷ When the flame goes out, the thermocouple automatically cuts the gas supply.
- ▷ Further information can be obtained from the separate instruction manual "Gas cooker".

The vehicle kitchen unit is fitted with a two-burner gas cooker (Fig. 87).



Fig. 87 Gas cooker

*Switching on:*

- Open the regulator tap on the gas bottle and the gas isolator tap "Cooker".
- Open the gas cooker lid.
- Turn the control knob (Fig. 87,1) on the burner you wish to use to the ignition position (large flame).
- Press the control knob down and hold it.
- Press the push button (Fig. 87,2). An ignition spark is created at the burner. If necessary, press the push button several times.
- Once the flame is burning, the control knob must be held down for 10 to 15 seconds, until the thermocouple automatically keeps the gas supply open.
- Release the control knob and turn to the desired setting.
- If ignition is unsuccessful, repeat the entire procedure.

*Switching off:*

- Turn the control knob to the 0-position. The flame fades.
- Close the gas isolator tap "Cooker" and the regulator tap on the gas bottle.

## 9.6 Gas oven (Dometic)



- ▶ Keep the ventilation openings on the gas oven open at all times.
- ▶ There must be no flammable or highly inflammable objects such as dishcloths, clothes, etc. near the gas oven when it is being lit or during operation. Fire hazard!
- ▶ If ignition has not taken place, repeat the entire procedure. If necessary, check if there is gas and/or current in the gas oven.
- ▶ If the gas oven still does not work, close the gas isolator tap and notify your service centre.
- ▶ If the burner flame is accidentally extinguished, turn the control knob to "O" and leave the burner off for at least 1 minute. Then ignite it again.
- ▶ Parts of the gas oven become very hot during operation. Never touch hot parts with bare hands.
- ▶ Place the meals, wire rack and drip pan into the gas oven so that they do not come into contact with the flame.
- ▶ Only ignite the oven and grill when the oven door is open.
- ▶ Always leave the oven door half open when grilling.



- ▷ Depending on the model the gas oven may come equipped with a grill.
- ▷ Before using the gas oven for the first time run it for 30 minutes at maximum temperature without any contents.
- ▷ When the flame goes out, the thermocouple automatically cuts the gas supply.
- ▷ If the ignition procedure fails repeatedly, turn the control knob to "O". Wait at least 1 minute and then ignite the gas oven manually. If necessary, check if there is gas and/or current in the gas oven. If the gas oven still does not work, close the gas isolator tap and notify your service centre.
- ▷ Further information can be obtained in the manufacturer's instruction manual.



Fig. 88 Gas oven

*Switching on the interior lighting:*

- Press the button for the interior lighting (Fig. 88,3). The interior lighting lights up for as long as the button is pressed.

*Switching on the oven:*

- Open the regulator tap on the gas bottle and the gas isolator tap "Oven".
- Fully open the oven door by the handle (Fig. 88,1).
- Press the control knob (Fig. 88,2), keep it pressed and turn it anticlockwise to the desired setting. Keep control knob (Fig. 88,2) pressed for a further 5-10 seconds. Ignition will take place automatically.



- Release control knob (Fig. 88,2).
  - Close oven door.
- Switching on the grill:*
- Open the regulator tap on the gas bottle and the gas isolator tap "Oven".
  - Fully open the oven door by the handle (Fig. 88,1).
  - Press and hold control knob (Fig. 88,2) and turn it in a clockwise direction. Keep control knob (Fig. 88,2) pressed for a further 5-10 seconds. Ignition will take place automatically.
  - Release control knob (Fig. 88,2).



- ▷ Do not close the oven door when grilling.

- Switching off:*
- Turn the control knob (Fig. 88,2) to "O". The flame fades.
  - Close the gas isolator tap "Oven" and the regulator tap on the gas bottle.

## **9.7 Refrigerator**

### **9.7.1 Operation (Thetford T1000)**



- ▶ Always keep the ventilation openings unobstructed.
- ▶ Due to technical reasons, the temperature in the refrigerator and in the freezer compartment cannot always be maintained at a constant level. Under adverse conditions, the food in the freezer compartment may thaw.



- ▷ Do not use any objects or hot air devices to accelerate defrosting.
- ▷ When the vehicle is exposed to intense sunlight: ventilate vehicle adequately.
- ▷ Before setting off, secure the products in the refrigerator against sliding.



- ▷ The refrigerator temperature depends on the ambient temperature (room temperature), the frequency the door is opened with, and the filling of the refrigerator. If required, readjust the cooling level.
- ▷ The living area battery has a limited power supply only. When the vehicle is stationary, do not use the refrigerator for long periods without it being connected to the 240 V connection.
- ▷ Check the collection tray for condensation before setting off and periodically during operation of the refrigerator.
- ▷ Further information can be obtained in the manufacturer's instruction manual.

**Operating modes**

The refrigerator is only operated with 12 V DC.

The 12 V power supply is always fed via the transformer/rectifier.

When the vehicle is in motion, the transformer/rectifier feeds the power from the vehicle generator to the refrigerator.

When the vehicle is stationary and **not** connected to the 240 V power supply, the transformer/rectifier supplies the refrigerator with power from the living area battery.

When the vehicle is stationary and connected to the 240 V power supply, the transformer/rectifier transforms the input voltage to 12 V and then supplies this current to the refrigerator.

Conversion between the individual supply types is automatic.

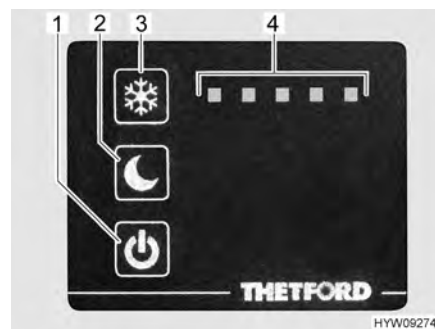

- 1 On/off button with blue indicator lamp
- 2 Night mode button
- 3 Temperature setting button
- 4 Display of the cooling level

Fig. 89 Operating controls (refrigerator)

**Switching on:** ■ Press on/off button (Fig. 89,1) and hold for approximately 2 seconds. The blue indicator lamp shows that the refrigerator is working. The display (Fig. 89,4) shows the set cooling level. This display is dimmed after approximately 10 seconds.

**Switching off:** ■ Press on/off button (Fig. 89,1) and hold for approximately 2 seconds. The blue indicator lamp will go out slowly.

The cooling levels, with which the refrigerator cools, must be selected depending on the room temperature. A high room temperature requires a higher cooling level. At a low room temperature, a lower cooling level would be enough.

**Setting the cooling level:** ■ Press the temperature setting button (Fig. 89,3) and hold for approximately 1 second. The currently set cooling level (Fig. 89,4) is displayed.  
 ■ Press the temperature setting button (Fig. 89,3) as often as necessary until the desired cooling level is reached.

The refrigerator has a night mode. When the night mode is switched on, the refrigerator works silently with low power.

**Switching on the night mode:** ■ Press the night mode button (Fig. 89,2). The blue indicator lamp shows that the night mode is active.

**Switching off the night mode:** ■ Press the night mode button (Fig. 89,2). The blue indicator lamp will go out. The refrigerator is working in normal mode again.

During operation, condensation may collect in the collection tray underneath the freezer compartment. The collection tray must be emptied periodically.

*Emptying the collection tray:*

- Push two pins (on the left-hand and the right-hand side of the collection tray) inwards.
- Pull collection tray out and empty it.

If an ice layer thicker than 3 mm has formed in several places of the freezer compartment, the refrigerator must be defrosted.

*Defrosting:*

- Switch off the refrigerator.
- Take all products out of the refrigerator.
- Leave the refrigerator door open.
- Place a suitable container underneath the drainage opening of the collection tray.
- Remove the stopper from the drainage opening.
- Wipe up the defrosting water with a sponge or cloth.
- When the refrigerator is defrosted: insert the stopper of the drainage opening again.
- Clean the refrigerator.

**9.7.2 Operation (Cruise 85)**



- ▷ The living area battery has a limited power supply only. When the vehicle is stationary, do not use the refrigerator for long periods without it being connected to the 240 V connection.

**Operating modes**

The refrigerator is only operated with 12 V DC.

The 12 V power supply is always fed via the transformer/rectifier.

When the vehicle is in motion, the transformer/rectifier feeds the power from the vehicle generator to the refrigerator.

When the vehicle is stationary and **not** connected to the 240 V power supply, the transformer/rectifier supplies the refrigerator with power from the living area battery.

When the vehicle is stationary and connected to the 240 V power supply, the transformer/rectifier transforms the input voltage to 12 V and then supplies this current to the refrigerator.

Conversion between the individual supply types is automatic.



Fig. 90 Operating control (refrigerator)

*Switching on:*

- Open the refrigerator door.
- Rotate the temperature controller (Fig. 89,1) clockwise from the "0" position to the "1" position. The device is switched on, the interior lighting (Fig. 89,2) is on.

*Switching off:* ■ Rotate the temperature controller (Fig. 89,1) anti-clockwise to the "0" position. A small amount of resistance will be felt.

*Adjusting the temperature:* ■ Set the temperature with the temperature controller (Fig. 89,1).

- Position "1" = lowest cooling power
- Position "7" = highest cooling power

*Defrosting:* ■ Switch off the refrigerator.

- Open the doors of the refrigerator and the freezer compartment and leave them open.
- Mop up the defrosting water with a sponge or cloth.
- Clean the device.

**Ventilation position** When the refrigerator is not in use, always leave the refrigerator door open. This prevents mould forming.



- ▷ When frozen food is kept in the freezer compartment, temperatures of -18 °C or lower are reached in the freezer compartment even when the temperature controller is set to a low setting.
- ▷ The refrigerator temperature depends on the ambient temperature (installation location), the frequency the door is opened with and the charging. If necessary, readjust the temperature controller.
- ▷ Further information can be obtained in the manufacturer's instruction manual.

### 9.7.3 Refrigerator door locking mechanism



- ▷ During the journey the refrigerator door must always be closed and locked in the closed position.



- ▷ Lock the refrigerator door in ventilation position when the refrigerator is switched off. This prevents mould forming.

There are two positions for locking the refrigerator door in place:

- Closed refrigerator door during travel and when the refrigerator is in operation
- Slightly opened refrigerator door as a ventilation position when the refrigerator is switched off

**T1000** The refrigerator is opened and closed with the handle on the door.  
The refrigerator door may be locked in ventilation position with a swivelling bracket.



Fig. 91 Locking device (normal position)



Fig. 92 Locking device (ventilation position)

*Locking in the ventilation position:*

- Open the refrigerator door.
- Swing the bracket (Fig. 91,1) to the front (Fig. 92).

If the refrigerator door is closed now, a gap will remain between the refrigerator door and the refrigerator.

**Cruise 85** The refrigerator is opened and closed with the handle on the door.

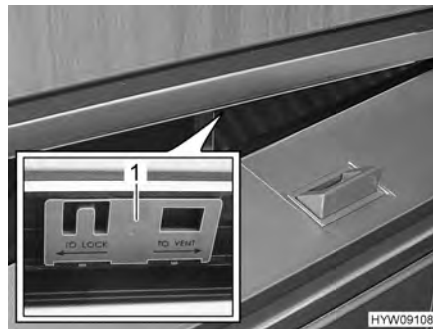

Fig. 93 Refrigerator door (ventilation position)

*Ventilation position:*

- Open the refrigerator door.
- Push slider (Fig. 93,1) towards the right.

If the refrigerator door is closed now, a gap will remain towards the refrigerator.



## Chapter overview

This chapter contains instructions regarding the sanitary fittings of the vehicle.

### 10.1 Water supply, general



- ▶ Fill water tank from supply systems that have been verified to provide drinking water quality.
- ▶ Only use such hoses or containers when filling that have been approved for use with drinking water.
- ▶ Thoroughly rinse filling hose or container with drinking water before use (2 to 3 times capacity).
- ▶ Empty filling hose or container completely after use and close openings of the filling hose or container.
- ▶ Water left standing in the water tank or in the water pipes becomes undrinkable after a short period. Therefore, before each use of the vehicle, thoroughly clean the water pipes and the water tank. After each use of the vehicle completely empty the water tank and the water pipes.
- ▶ In the case of lay-ups lasting more than a week disinfect the water system before using the vehicle (see chapter 11).



- ▷ If the vehicle is not used for several days or if it is not heated when there is a risk of frost, empty the entire water system. Make sure that the 12 V power supply on the panel is switched off. Otherwise, the water pump will overheat and may get damaged. Leave the water taps on in central position. Leave all drain cocks open. Frost damage to appliances, frost damage to the vehicle and deposits in water-carrying components can be avoided in this way.
- ▷ The water pump will overheat without water and can get damaged after one minute at the latest. Never operate water pump when the water tank is empty.

The vehicle is equipped with a fitted water tank. An electric water pump pumps the water to the individual water taps. Opening a water tap automatically switches on the water pump and pumps water to the tap.

The waste water tank collects the waste water. The water level in the water and waste water tanks can be checked on the panel.



- ▷ Before the water fittings can be used, the 12 V power supply on the panel must be switched on. Otherwise the water pump will not work.
- ▷ When the water tank is re-filled, an air bubble may form at the bottom of the pump. This air bubble will prevent water from being drawn in. Shake the water pump up and down energetically in the water.

## 10.2 Water system

### 10.2.1 Water tank

The water tank holds up to 100 l.



- ▷ For driving safety and for regulatory reasons, when the vehicle is in motion, the fill quantity must be reduced to approximately 20 litres. If the water is drained using the safety drainage handle (see section 10.2.5), a residual quantity of approximately 20 litres will remain in the water tank.

The water tank is installed in the right hand bed chest (Fig. 94,4) or in the right side cabinet.



Fig. 94 Water tank

*Access to the water tank:*

- Fold up the right bed base (in the direction of travel).

The water pump (Fig. 94,1), handle (Fig. 94,2) for draining off the water and the cleaning opening (Fig. 94,3) can be accessed through this service opening.

### 10.2.2 Filling the water system



- ▶ When filling the water tank, observe the maximum permissible gross weight of the vehicle. Luggage must be reduced accordingly when the water tank is full.



- ▷ The water pump will overheat without water and can get damaged after one minute at the latest. Never operate water pump when the water tank is empty.



- ▷ The water quantity can be monitored on the panel while the water tank is filled.

- Position the vehicle horizontally.
- Switch on the 12 V power supply on the panel.



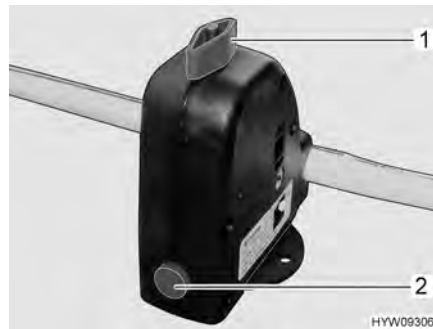

Fig. 95 Safety/drainage valve (Truma)

- Close the safety/drainage valve (Fig. 95). Turn the knob (Fig. 95,1) perpendicular to the safety/drainage valve and push the push button (Fig. 95,2) in. If the temperature is below 6 °C, the safety/drainage valve cannot be closed.



Fig. 96 Drain cock (Truma boiler)

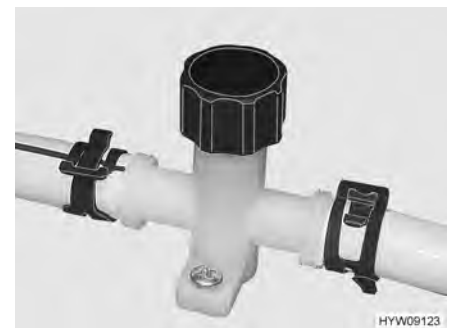

Fig. 97 Drain cock (water pipe)

- Close all drain cocks (Fig. 96 or Fig. 97). To do so, close the caps by turning them in a clockwise direction and set the rocking lever in a horizontal position. The position of the safety/drainage valve and the drain cocks is specified in the section 10.6 at the end of this chapter.
- Close all water taps.
- Close drainage opening on the water tank.
- Open the drinking water filler neck on the outside of the vehicle.
- Fill the water tank with drinking water. Use a water hose, a water canister with a funnel or similar for filling.
- Set all the water taps to "Hot" and open them. The water pump is turned on. The warm water pipes are filled with water.
- Keep the water taps open until the water flowing out of the water taps has no bubbles in it. This is the only way to ensure that the boiler is full of water.
- Set all water taps to "Cold" and leave them open. This will fill the cold water pipes with water.
- Keep the water taps open until the water flowing out of the water taps has no bubbles in it.
- Close all water taps.
- Close drinking water filler neck.
- Check that the cap on the water tank is not leaking.

## 10.2.3 Topping up the water



- ▶ When filling the water tank, observe the maximum permissible gross weight of the vehicle. Luggage must be reduced accordingly when the water tank is full.

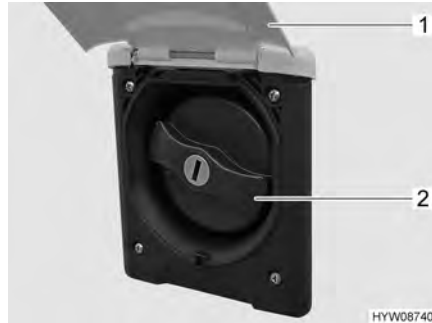

Fig. 98 Cap (drinking water filler neck)

The drinking water filler neck is on the right or left side of the vehicle, depending on the model.

The drinking water filler neck is marked by the symbol "🚰".

*Opening the drinking water filler neck:*

- Swivel the external flap (Fig. 98,1) upwards.
- Insert key into locking cylinder and turn a quarter turn. The cap is unlocked.
- Remove the key.
- Turn the blue cap (Fig. 98,2) one quarter turn.
- Remove the cap.

*Filling with water:*

- Fill the water tank with drinking water. Use a water hose, a water canister with a funnel or similar for filling.

*Closing the drinking water filler neck:*

- Place cap on the drinking water filler neck.
- Turn cap one quarter turn.
- Insert key into locking cylinder and turn a quarter turn. The cap is locked.
- Remove the key.
- Check that the cap sits firmly on the drinking water filler neck.
- Swivel external flap downwards and close it.

### 10.2.4 Draining water

**Handle** The handle for draining off the water is mounted on the water tank.



Fig. 99 Handle (water drain)

- Opening:*
- Turn the handle (Fig. 99,1) on the water anticlockwise as far as possible.
- Closing:*
- Turn the handle (Fig. 99,1) on the water tank clockwise as far as possible.

### 10.2.5 Reducing the water quantity for mobile operation



- ▶ When filling the water tank, observe the maximum permissible gross weight of the vehicle. Luggage must be reduced accordingly when the water tank is full.

**Handle** The handle is installed on the water tank.

- Closing:*
- Turn the handle (Fig. 99,1) on the water tank in a clockwise direction as far as it will go.
  - Fill the water tank with drinking water.
- Opening:*
- Turn the handle (Fig. 99,1) on the water tank in an anticlockwise direction as far as it will go. Excess water will drain away leaving approx. 20 litres in the tank.

**10.2.6 Emptying the water system**



- ▷ If the vehicle is not used for several days or if it is not heated when there is a risk of frost, empty the entire water system. Make sure that the 12 V power supply on the panel is switched off. Otherwise, the water pump will overheat and may get damaged. Leave the water taps on in central position. Leave the safety/drainage valve and all drain cocks open. Frost damage to appliances, frost damage to the vehicle and deposits in water-carrying components can be avoided in this way.



- ▷ Take note of the environmental tip in this chapter.

To empty and ventilate the water system, proceed as follows. This prevents frost damage and deposits:

- Position the vehicle horizontally.
- Switch off the 12 V power supply on the panel.
- Switch off the 240 V power supply on the 240 V fuse box.
- Switch off the boiler.



Fig. 100 Safety/drainage valve

- Open the safety/drainage valve (Fig. 100). To do this, turn the knob (Fig. 100) parallel to the safety/drainage valve.



Fig. 101 Drain cock (Truma boiler)

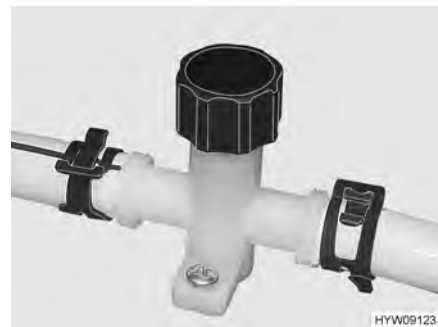

Fig. 102 Drain cock (water pipe)

- Open all drain cocks (Fig. 101 or Fig. 102).
- Unscrew the cap of the water tank.
- Remove water pump and water hose from the water tank.
- Open the water tank drain.
- Open all water taps and set to the central position.
- Hold the shower handset up.

- Unscrew the lock ring on the water tank.
- Take water pump (fitted to the cover) as far as the connecting lines allow.
- Hold the water pump up until the water pipes are completely empty.
- Check whether the water tank is completely empty.
- Set shower handset down in the shower tray.
- Blow out the remaining water in the water pipes (max. 0.5 bar). In order to do this, remove the water pipe from the water pump and blow into the water pipe in the direction of the appliances.
- Empty the waste water tank. Take note of the environmental tips in this chapter.
- Empty the sewage tank. Take note of the environmental tips in this chapter.
- Clean the water tank and then rinse it out thoroughly.
- Let the water system dry for as long as possible.
- After emptying, leave all water taps on in the central position.
- Leave all the drain cocks and safety/drainage valves open.

### 10.3 Waste water tank



- ▷ If there is a risk of frost, empty the waste water tank and leave the drain cock open.
- ▷ Never pour boiling water directly into the sink outlet. Boiling water could cause deformation and leaks in the waste water pipe system.



- ▷ Only empty the waste water tank at disposal stations, camping sites or caravan sites especially provided for this purpose.

Waste water from the kitchen and washing unit flows through plastic pipes into the waste water tank.

The waste water tank is located underneath the floor of the vehicle.

**Volume** The waste water tank holds 90 l.

**Cleaning** Clean the waste water tank several times a year (see chapter 11).

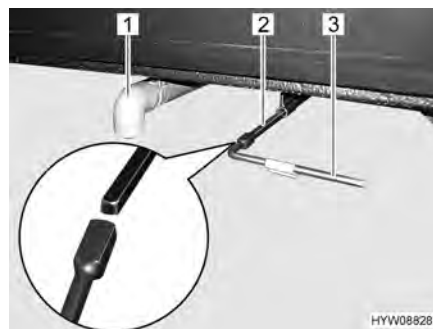

Fig. 103 Operating lever and drain pipe (waste water tank)

- Emptying:**
- Place the drain pipe (Fig. 103,1) directly above the disposal station or attach the waste water hose (special equipment) onto the drain pipe (Fig. 103,1).
  - Open the drain cock. To do this, attach the supplied square spanner (Fig. Fig. 103,3) onto the square of the drain cock (Fig. 103,2).

- To do this, turn the square spanner (Fig. 103,3) a quarter turn anticlockwise. The waste water is drained.
- After the waste water has drained off: Close the drain cock again. To do this, turn the square spanner (Fig. 103,3) a quarter turn clockwise.
- Remove the square spanner (Fig. 103,3) and store it.
- If present, remove and store the waste water hose.

### 10.4 Toilet compartment



- ▷ Do not transport any loads in the shower tray. The shower tray or other items of equipment in the toilet compartment can be damaged.



- ▷ For ventilation purposes during or after a shower, and for drying wet clothing, close the toilet compartment door and open the window or the toilet compartment skylight. This improves the air circulation.
- ▷ After taking a shower, rinse soap residue from the shower tray, otherwise cracks can appear in the shower tray over time.
- ▷ After using the shower, wipe it dry to prevent moisture from collecting.
- ▷ Pitch the vehicle so that it is as horizontal as possible. Otherwise, the water from the shower tray will not be able to drain properly.
- ▷ During the journey, close the louvre door (Fig. 104,1). An open louvre door could otherwise cause noises.
- ▷ Further information about cleaning the toilet compartment can be found in the section 11.2.

#### Shower grate insert

The shower grate insert is made of solid wood. The shower grate insert protects the shower tray and provides a dry floor, even after taking a shower.



Fig. 104 Shower grate insert

*Observe the following for a long service life:*

- Before taking a shower, take the shower grate insert (Fig. 104,2) out of the shower.
- After taking a shower, put the shower grate insert back into the shower tray.
- At least twice a year, apply a commercial solid wood oil to the shower grate insert using a lint-free cloth in fibre direction (observe the manufacturer's instructions).

### 10.4.1 Wash basin

The toilet compartment is fitted with a fold-up wash basin.



Fig. 105 Wash basin (folded upwards)

*Folding upwards:*

- Grip the wash basin (Fig. 105,1) on the front edge and swivel it upwards to the wall until it engages.

*Folding down:*

- Reach into the opening (Fig. 105,2) and press the latch towards the rear.
- Slowly swivel the wash basin downwards as far as it will go.

## 10.5 Toilet



- ▷ Do not load the toilet with more than a maximum of 120 kg.
- ▷ If there is any risk of frost and the vehicle is not heated, empty the sewage tank.
- ▷ Do not sit on the lid of the toilet. The lid is not designed to bear the weight of a person and could break.
- ▷ Use a suitable chemical for this toilet. The ventilation will merely remove the odour but not germs and gases. Germs and gases will have a detrimental effect on the sealing rubbers.



- ▷ Further information can be obtained in the manufacturer's instruction manual.



- ▷ Only empty the sewage tank at disposal stations, at camping sites or caravan sites, that are especially provided for this purpose.

**10.5.1 Swivel toilet**

The flushing of the Thetford toilet is fed directly from the water system of the vehicle. The toilet bowl can be moved into the optimal position.

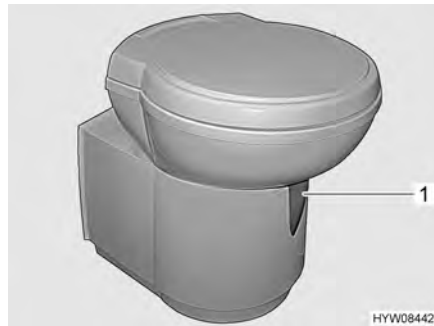

Fig. 106 Thetford toilet bowl (swivelling)



Fig. 107 Flush button/indicator lamp (Thetford toilet)

The operating unit is located close to the toilet bowl.

- Flushing:*
- Before flushing open the sliding trap of the Thetford toilet. To do this, push the slide lever (Fig. 106,1) in an anticlockwise direction.
  - For flushing, press the blue flush button (Fig. 107,1).
  - After flushing close the sliding trap. To do this, push the slide lever in a clockwise direction.

The indicator lamp (Fig. 107,2) lights up whenever the sewage tank has to be emptied.

**10.5.2 Toilet with fixed seat**

The toilet is flushed using a separate flush water tank in the toilet.

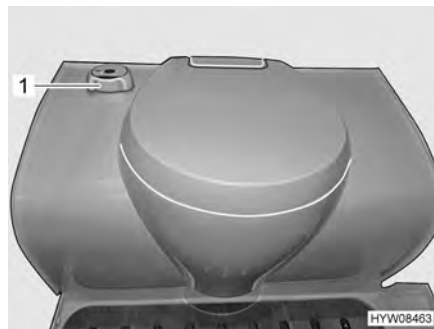

Fig. 108 Thetford toilet

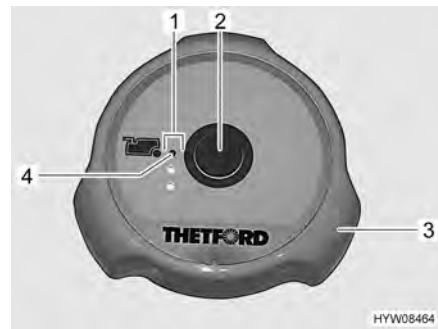

Fig. 109 Flush button/indicator lamps (Thetford toilet)

The toilet can be used with the sliding trap open or closed.

- Opening the sliding trap:*
- Turn the handle (Fig. 108,1) in an anticlockwise direction.
- Closing the sliding trap:*
- Turn the handle (Fig. 108,1) clockwise.



- Flushing:*
- Before flushing open the sliding trap of the Thetford toilet. To do this, turn the handle (Fig. 109,3) in an anticlockwise direction.
  - For flushing, press the blue flush button (Fig. 109,2).
  - After flushing close the sliding trap. To do this, turn the handle (Fig. 109,3) in a clockwise direction.

The indicator lamps (Fig. 109,1) show the filling level of the sewage tank. The red indicator lamp (Fig. 109,4) lights up whenever the sewage tank has to be emptied.

### 10.5.3 Emptying the sewage tank



- ▷ The sewage tank can only be taken out if the sliding trap is closed.



Fig. 110 Flap (sewage tank)

- Slide the slide lever on the toilet bowl in a clockwise direction. The sliding trap is closed.
- Open the flap for the sewage tank on the outside of the vehicle. Insert the key into the locking cylinder of the push-button lock (Fig. 110,1) and turn a quarter turn in a clockwise direction.
- Remove the key.
- Press both push-button locks (Fig. 110,2) simultaneously with your thumb and open the flap for the sewage tank.



Fig. 111 Sewage tank (in the vehicle)



Fig. 112 Sewage tank



Fig. 113 Sewage tank (in the vehicle) (alternative)



Fig. 114 Sewage tank (alternative)

- Pull the safety clamp (Fig. 111,3) upwards and use the handle (Fig. 111,2) to pull out the sewage tank (Fig. 111,1).
- Or:  
Pull the retaining clip (Fig. 113,1) upwards and pull out the sewage tank (Fig. 113,2).
- At a disposal station that is especially provided for this purpose, swivel the outlet pipe (Fig. 112,1 or Fig. 114,1) forwards and unscrew cover (Fig. 112,2 or Fig. 114,2).
- Press the coloured ventilation button (Fig. 112,3 or Fig. 114,3) and hold it there until the sewage tank is empty.
- Clean the sewage tank with fresh water.
- Close outlet pipe with cover and swivel it back.
- Push sewage tank into the disposal chute until it engages.
- Close flap for sewage tank.
- Fill in new sanitary liquid.

#### 10.5.4 Winter operation



- ▷ Do not use antifreeze. Antifreeze can damage the toilet.

When the vehicle is being heated, the toilet, the water tank and the sewage tank are in a frost-protected area. This means that the toilet can also be used in winter.

If the vehicle is not being heated and there is a risk of frost in the water tank, drain off the sewage tank and the water pipes. This prevents frost damage.

**10.5.5 Temporary lay-up**



- ▷ If the toilet is not to be used for an extended period, empty the water tank, the sewage tank and the water pipes.

*Laying up the toilet:*

- Empty the water tank.
- Flush the toilet until no more water runs into the toilet. Note that the pump can get damaged after one minute at the latest if it runs dry.
- Empty the sewage tank.
- Rinse the sewage tank thoroughly.
- Leave the drainage neck on the sewage tank open.
- Let the sewage tank dry for as long as possible.

**10.6 Installation positions**

Depending on the model, the components of the sanitary fittings are accessible at the following positions:

Model	Water drain valves	Safety/drainage valve	Fresh water tank
Yosemite	Under floor trap	In the seat box next to the boiler	Underneath right-hand bed chest cover
Serengeti	In the seat box, behind side flap, underneath floor trap	In the seat box, behind side flap, underneath floor trap	Bed chest underneath cover
Sierra Nevada	Under floor trap	In the seat box next to the boiler	Rear right-hand storage cupboard, underneath floor plate
Grand Canyon/ Grand Canyon Classic	Under floor trap	In the seat box next to the boiler	Underneath right-hand bed chest cover
Yellow-stone	Under floor trap	In the seat box next to the boiler	Underneath cover, on the right-hand side of the bed chest
Ayers Rock	In the seat box, behind side flap, underneath floor trap	In the seat box, behind side flap, underneath floor trap	Underneath right-hand bed chest cover
Grand Canyon S	Under floor trap	In the seat box next to the boiler	Underneath right-hand bed chest cover
Redwood S	Not known at the time of going to press	Not known at the time of going to press	Not known at the time of going to press



## Chapter overview

This chapter contains instructions regarding the care of the vehicle.

At the end of the chapter there is a checklist of measures you must carry out if you are not going to use the vehicle for an extended period of time.

The checklist address the following topics:

- temporary lay-up
- winter lay-up
- start-up after a lay-up

### 11.1 External care

#### 11.1.1 General

Standard external care consists of regular washing. The use and the environmental conditions will determine how often the vehicle needs to be washed. Wash the vehicle more frequently in areas which are exposed to heavy air pollution or heavy traffic or roads treated with de-icing salts. If the vehicle is exposed to salty and humid air (coastal areas, humid climates), wash the vehicle more frequently.

Do not park under trees if at all possible. The resin-like discharge which many trees secrete, give the paintwork a matt look and can promote the onset of corrosion.

Wash off bird droppings straight away and thoroughly, as the acid it contains is extremely corrosive.

#### 11.1.2 Washing with a high-pressure cleaner



- ▷ Do not clean the tyres with a high-pressure cleaner. The tyres might be damaged.
- ▷ Do not spray external applications (deco-films) directly with the high-pressure cleaner. The external applications could come off.

Before cleaning the vehicle with a high-pressure cleaner, observe the operating instructions of the high-pressure cleaner.

When cleaning with the nozzle for circular jet between the vehicle and the cleaning nozzle, maintain a minimum distance of approx. 700 mm.

Take into consideration that the jet of water comes out of the cleaning nozzle with pressure. The vehicle may be damaged by incorrect handling of the high-pressure cleaner. The temperature of the water should not be above 60 °C. Keep the jet of water in constant movement during the washing process. Do not direct the water jet at clearances, built-in electrical parts, plugs, seals, the ventilation grill or the skylights. The vehicle may be damaged or water may enter the interior.

### 11.1.3 Washing the vehicle



- ▷ Never clean the vehicle in the car wash. The brush rollers can damage the external applications. Water can enter the waste gas vents or the forced ventilations. The vehicle could be damaged.
- Wash the vehicle only on a washing site intended for this purpose. Avoid full sunshine. Observe environmental measures.
- When using a cleaning agent, observe the manufacturer's instructions for use. Cleaning agent must be pH-neutral.
- First, test the suitability of the cleaning agent on an inconspicuous spot.
- Only clean external applications and synthetic parts with plenty of warm water, dish washing liquid and soft cloth.
- Wash down the vehicle with plenty of water, a clean sponge or a soft brush. In the case of stubborn dirt add dish washing liquid to the water.
- Painted exterior walls may also be cleaned with a caravan cleaner.
- Treat rubber seals on doors with a conventional rubber care product.
- Treat locking cylinder on doors with graphite dust.

### 11.1.4 Windows of acrylic glass



Acrylic glass windows are delicate and require very careful handling.

- ▷ Never rub acrylic glass windows dry as dust particles might damage the surface!
- ▷ Only clean acrylic glass windows with plenty of warm water, some dish washing liquid and a soft cloth.
- ▷ Never use glass cleaning agents with chemical, abrasive or alcohol-containing additives. Premature brittleness of the panes and associated cracks may result from their use.
- ▷ Avoid contact of cleansing agents used for the body (e.g. tar- or silicone-removing agents) with acrylic glass.
- ▷ Do not clean vehicle in car wash.
- ▷ Do not attach stickers to the acrylic glass windows.
- ▷ Having cleaned the vehicle rinse acrylic glass with sufficient clear water.
- ▷ Treat rubber seals with a conventional rubber care product.



- ▷ An acrylic glass cleanser with antistatic effect is suitable for a follow-up treatment. Small scratches can be treated with an acrylic glass polish. These agents are available at the accessories shop.

### 11.1.5 Add-on parts made of glass-fibre reinforced plastic (GRP)



- ▷ Avoid contact between polish and window rubber and piping.
- ▷ The glass-fibre reinforced plastic (GRP) may not become too hot. Therefore when polishing with a polishing machine, keep the machine in constant motion.

GRP add-on parts can turn yellow or become weather-worn due to insufficient care for the vehicle or ageing of the material.

GRP add-on parts should therefore undergo regular follow-up treatment. This way, these parts will not turn yellow and the sealing of the surface remains intact.

*Follow-up treatment of GRP add-on parts:*

- Wash the vehicle and allow to dry as described above. Check if the GRP add-on parts are clean and dry.
- Apply the polisher with a soft cloth evenly on the surface of the GRP add-on part.
- Wait until a light grey film forms.
- Wipe the GRP add-on part with a dry, soft cloth. Move the cloth in circles over the surface of the GRP add-on part.

We recommend using a polishing machine for this work.



- ▷ Paint protection has to be used to preserve the polish. Please read the instructions of the paint protection for details on how to apply it.

### 11.1.6 Underbody

The underbody of the vehicle is partly coated with an age-resistant underbody protection. Should the underbody protection be damaged, repair immediately. Do not treat areas coated with underbody protection with spray oil.



- ▷ Only use products approved by the manufacturer. Our authorised dealers and service centres will be happy to advise you.

### 11.1.7 Engine compartment



- ▷ Cleaning and care of the engine compartment may only be carried out while the ignition is switched on.
- ▷ Let the engine cool down before carrying out any work in the engine compartment. There is a danger of burns when touching motor components that are still hot!
- ▷ Before carrying out any work in the engine compartment, read and observe the corresponding warning and handling instructions in the operating manual of the base vehicle manufacturer.
- ▷ Have an engine washing only carried out by an authorised specialist workshop.
- ▷ Do not aim the steam jet directly at the lamp housings, actuators or seals. This may prevent humidity in the headlights and the defects resulting therefrom.
- ▷ Do not aim the steam jet at the windscreen wiper motor and the wiper mechanics.
- ▷ Only apply protective engine lacquer when the components in the engine compartment have cooled down and are clean.
- ▷ Only use lubricants, greases and fluids authorised by the base vehicle manufacturer.

The body manufacturer excludes any guarantee for damages, leaks, or the failure or electrical components that appear after an engine washing.

### 11.1.8 Windscreen washer system and windscreen wipers



- ▷ Only fill the cleaning agents (with/without frost protection) into the washer fluid container which are listed in the operating manual of the base vehicle manufacturer and in the mixing ratio specified therein. Do not use any radiator frost protection or other products. These products affect the cleaning effect and attack the windscreen blades.
- ▷ Do not switch the windscreen washer system or the windscreen wipers on when the windscreen blades are frozen to the windscreen. Release the windscreen blades first using a defrosting product.
- ▷ Do not remove the snow accumulated on the windscreen with the windscreen wipers. Remove the snow from the windscreen with a brush first.
- ▷ Do not switch on the windscreen wipers on a dry windscreen.
- ▷ Do not clean the windscreen wiper mechanics and the windscreen wiper motor with a steam blaster.
- Check the correct functioning of windscreen washer system and windscreen wipers periodically.
- Check the filling level of the washer fluid container periodically. Only if sufficient cleaning fluid reaches the windscreen, the windscreen wipers will be able to clean it in a satisfactory way. A clear view contributes decisively to safe driving.
- Before the frost period starts, fill the washer fluid container with windscreen cleaning product containing sufficient frost protection.
- Refill windscreen washing fluid on time. Only use clean water to dilute the windscreen cleaning product.
- Remove insect residues from the windscreen blades as soon as possible.
- Clean the windscreen blades periodically with a windscreen cleaning product. To do this, move a sponge or a cloth along the rubber strip.
- Remove car wax residues after the vehicle washing using a wax dissolving windscreen cleaning product.
- Remove dirt accumulations on the nozzles of the windscreen washer system periodically.
- After journeys on heavily soiled roads, spray clear water on the wiper nozzles to prevent incrustations.
- Clean obstructed wiper nozzles with a fine needle.

### 11.1.9 Air conditioning unit



- ▷ Do not clean the air conditioning unit with a high-pressure cleaner. Water entering can damage the air conditioning unit.
- ▷ Do not clean vehicle in car wash.
- ▷ Do not use any sharp or hard objects when cleaning. Otherwise the air conditioning unit and sunroof can be damaged.



- ▷ Use only the cleaning agents recommended by the manufacturer to clean the sunroof. Our authorised dealers and service centres will be happy to advise you.



- Use only water and a gentle cleaning agent to clean the air conditioning unit.
- Wipe the air conditioning unit housing and the air outlet occasionally with a damp cloth.
- Clean the remote control occasionally with a slightly damp cloth. Clean the display with a spectacles cleaning cloth.
- If necessary, clean the blinds with a mild soap solution and plenty of water.
- Remove leaves and other dirt from the ventilation openings on the air conditioning unit regularly.
- Check the condensation drain holes regularly to ascertain whether the condensation can run off freely.
- Clean the filters on both sides of the air discharge unit regularly.
- Change the active carbon filters on both sides of the air discharge unit annually.
- Inspect the profile seal to the vehicle roof for damage annually.



- ▷ Further information can be obtained in the manufacturer's instruction manual.

### 11.1.10 Entrance step

If the entrance step is lubricated, coarse particles of dirt can settle on the lubricant during the journey and cause damage to the operating mechanism of the entrance step. Therefore, do not lubricate the moving parts of the entrance step.

## 11.2 Interior care



- ▷ If possible, treat stains immediately.
- ▷ Acrylic glass windows are delicate and require very careful handling (see section 11.1.4).
- ▷ Synthetic parts in the toilet and living area are very delicate and should be treated with care. Do not use solvents, alcohol-containing cleansers or scourers. This procedure will help you to avoid brittleness and formation of cracks.
- ▷ Hair colourants, nail varnish, cigarette ash and similar substances may cause permanent stains or discolouration. For this reason, you should prevent these substances from getting onto plastic parts. If they do get onto plastic parts, you should remove these substances immediately.
- ▷ Do not pour any corrosive agents into the drain holes. Never pour boiling water directly into the drain holes. Corrosive agents and boiling water cause damage to drainage pipes and siphon traps.
- ▷ Do not use vinegar based products to clean the toilet and water system, or for decalcification of the water system. Vinegar-based products may cause damage to seals or parts of the installation. Use standard decalcifying products for decalcification.
- ▷ Save water. Mop up all remaining water.



- ▷ For information about the use of maintenance products, our representatives and service centres will be glad to advise.

- Surface and knobs of furniture, lamps and synthetic parts in the toilet and living area should be cleaned with water and a wool cloth. A mild cleanser may be added to the water. If required, use furniture polish for the painted surfaces.
- Curtains and net curtains should be dry cleaned.
- Vacuum clean the carpet, if necessary clean with carpet shampoo.
- Clean PVC-floor covering with a mild, soapy cleanser for PVC floors. Do not place carpet on wet PVC-floor covering. The carpet and the PVC-floor covering may stick together.
- Brush insect screen with a soft brush or vacuum with the brush attachment of the vacuum cleaner.
- Brush blinds with a soft brush or vacuum with the brush attachment of the vacuum cleaner. Grease or stubborn dirt may be removed with a mild soap at 30 °C (curd soap).
- Brush Roman shades with a soft brush or vacuum with the brush attachment of the vacuum cleaner. Grease or stubborn dirt may be removed with a mild soap at 30 °C (curd soap).
- Unrolled seat belts can be cleaned with warm soapsuds. The seat belt must be completely dry before being rolled up.
- Wipe the canvas of the elevating roof only with a damp, soft cloth so as not to alter the impregnation.

### 11.3 Kitchen installation

#### 11.3.1 General notes on care

- Before the first use, heat up the empty oven and grill such that unpleasant odours from manufacturing may dissipate.
- Never clean the sink or the gas cooker with a scourer. Avoid anything which may cause scratching or grooves.
- The surface of the kitchen worktop is not scratch proof. When working with sharp objects, always use a pad. Only use soft cleaning agents for cleaning and care. Do not use any abrasive or scratching intensive treatment products nor scratching sponges.
- Clean the burners on the gas cooker using a damp cloth only. Prevent any water from penetrating the burner covers. Water may damage the burners on the gas cooker.
- Clean the surface of the cooker, and particularly the hob, with warm water and some washing-up liquid. Scouring agent or sharp objects damage the surface of the hob.  
The surface of the hob is easier to clean when it is still slightly warm. Before cleaning, ensure that the hob is only still warm to the touch (residual heat indicator has gone out).  
Always clean the hob before using it again.
- When cleaning the burner ring, ensure that the holes are not obstructed.
- The knobs can be pulled off for cleaning.
- Clean the external surfaces of the kitchen installation with a wet cloth without abrasive, corrosive or chloride containing cleaning agents. Do not use steel wool.

- Immediately remove acidic or alkaline substances (vinegar, salt, lemon juice, etc.).
- Let the oven and grill cool down before cleaning. Hot surfaces may be damaged due to cold water or a wet cloth. Clean enamelled surfaces only with soap water or washing-up liquid containing water.

### 11.3.2 Stainless steel surfaces



- ▷ Do not clean the stainless steel surfaces with bleaching agents, with products that contain chloride or hydrochloric acid, baking powder nor with silver polish.
- ▷ Do not use scouring agent nor coarse sponges.



- ▷ Prior to cleaning, test the suitability of the cleaning product for the surface on an unobtrusive spot.
- ▷ Dry the surfaces thoroughly after cleaning to prevent limescale.
- ▷ In the case of brushed stainless steel surfaces, wipe in a direction of the grinding.

*Removing scratches from the surface:*

- Treat the stainless steel surface with a soft cleaning cloth and with a special stainless steel cleaner.
- Rinse the stainless steel surface and dry it with household wipes.

*Removing stubborn dirt and burnt-in fat:*

- Clean the stainless steel surface with an ordinary household sponge and with cleanser.
- Rinse the stainless steel surface and dry it with household wipes.

*Removing fingerprints:*

- Clean the stainless steel surface with a soft cleaning cloth and soapy water or a glass cleaning agent.
- Rinse the stainless steel surface and dry it with household wipes.

*Removing coffee or tea stains:*

- Treat the stainless steel surface with a baking soda solution. Allow the baking soda solution to work in for 15 minutes.
- Rinse the stainless steel surface and dry it with household wipes.

*Removing rust stains:*

- Clean the stainless steel surface with an ordinary household sponge and with cleanser. If necessary, use a soft cleaning cloth and stainless steel cleaner.
- Rinse the stainless steel surface and dry it with household wipes.

### 11.3.3 Refrigerator

- Clean the exterior and interior of the refrigerator with a soft cloth and lukewarm water (containing a mild cleaning agent).
- Then, wash the refrigerator out with clear water and let it dry.
- Keep the defrosted water drain channel free of sediments.
- To prevent material changes, do not use any soap, nor any sharp, granular or soda containing cleaning agents.
- Keep oil and grease away from the door seal.

## 11.4 Cushions

The care and cleaning instructions below are for assistance only. They are not a guarantee of successful cleaning. These instructions cannot form the basis for any warranty claims.



- ▷ If possible, treat stains immediately.
- ▷ Never use household cleaners to remove marks (e.g. detergents).
- ▷ Before treating marks, test the cleaning on a hidden part of the upholstery covers. This will show you whether the cleaning will damage the materials or dyes.
- ▷ Always only dab moist or greasy marks, never rub them. It is most effective to gently press an absorbent cloth or a sponge onto the mark.
- ▷ Do not wash upholstery.
- ▷ When cleaning leather covers, make sure that the leather is not soaked through and that no water seeps through the seams of the leather covers.



- ▷ Treat the mark from the outside working inwards. This prevents the mark from spreading.
- ▷ In the case of both solid or softer contamination, first remove the coarse parts. Next, carefully scrape off the mark with a blunt knife or spatula.
- ▷ If the mark has already dried in, carefully brush off the coarse parts. Next, dab off the mark with a damp cloth or sponge.
- ▷ The upholstery will fade over time, if it is exposed to sunlight. If the temperature within the vehicle rises rapidly as well, the colour will change at an accelerated rate.  
Therefore, we recommend to close the shades on the windows when there is strong sunlight. Ensure that heat does not build up when you close the blind.

*Removing grease, oil, wine, milk, non-alcoholic beverages:*

- Moisten a cloth with commercial water-based cleaning agent. (Alternatively, mix 2 tablespoons of ammoniac with 1 litre of water.)
- Gently dab the stain with the cloth.
- Turn the cloth frequently so that the mark only comes into contact with a clean part of the cloth.

*Removing urine, sweat:*

- Moisten a cloth with commercial water-based cleaning agent. (Alternatively, mix 2 tablespoons of ammoniac with 1 litre of water.)
- Gently dab the stain with the cloth.
- Turn the cloth frequently so that the mark only comes into contact with a clean part of the cloth.

*Removing chocolate, coffee:*

- Moisten cloth with lukewarm water.
- Dab the stain with the cloth.

*Removing fruit residues:*

- Moisten cloth with cold water.
- Dab the stain with the cloth.

*Removing wax:*

- Carefully scrape off the wax with a blunt knife or spatula.
- Cover the mark with several layers of waterleaf paper and iron.

- Removing blood:*
- Mix 2 tablespoons of salt and 1 litre of water.
  - Moisten the stain and dab with a dry cloth.
  - Dab stubborn stains with ammonia solution.

- Removing (ball pen) ink:*
- Moisten cloth with benzine.
  - Gently dab the stain with the cloth.
  - Turn the cloth frequently so that the mark only comes into contact with a clean part of the cloth.

- Removing mud:*
- Carefully remove as much mud as possible with a blunt knife or a spatula.
  - Allow the mud to dry and then remove it with a vacuum cleaner.
  - For stubborn marks, moisten a cloth with commercial water-based cleaning agent. (Alternatively, mix 2 tablespoons of ammonia solution with 1 litre of water.)
  - Gently dab the stain with the cloth.
  - Turn the cloth frequently so that the mark only comes into contact with a clean part of the cloth.

- Removing pencil:*
- Moisten cloth with a mild, water-free and pure fabric cleaning agent.
  - Gently dab the stain with the cloth.
  - Turn the cloth frequently so that the mark only comes into contact with a clean part of the cloth.

- Removing vomit:*
- Carefully remove vomit.
  - Wash cushion with cold water.
  - Moisten a cloth with commercial water-based cleaning agent. (Alternatively, mix 2 tablespoons of ammoniac with 1 litre of water.)
  - Gently dab the stain with the cloth.
  - Turn the cloth frequently so that the mark only comes into contact with a clean part of the cloth.

## 11.5 Water system

### 11.5.1 Cleaning the water tank

- Empty the water tank and close the drainage opening.
- Remove the cap of the water tank.
- Fill water tank with water and some washing-up liquid (do not use any scourers).
- Using a trade standard brush for washing dishes, scrub the water tank until there is no longer any visible deposit.
- Scrub also the pump housing.
- If possible, clean fresh water sensors through the cleaning openings by hand.
- Rinse water tank with copious amounts of drinking water.



- ▷ If, due to the design of the water tank, it is not possible to clean the water tank mechanically: Use a suitable chemical cleaning agent.

The authorised dealers would be happy to assist you in choosing a suitable cleaning agent.

Follow the cleaning agent manufacturer's instructions.

### 11.5.2 Cleaning the water pipes



- ▷ Only use suitable cleaning agents as sold by the specialist trade.
- ▷ The cleaning agent must meet national regulations and be approved (if required).



- ▷ Collect any emerging mixture of water and cleaning agent for correct disposal.

- Empty the water system.
- Close all drainage openings and drain cocks.
- Fill mixture of water and cleaning agent into the water tank. Observe the manufacturer's instructions regarding the mixing ratio.
- Open the drain cocks one by one.
- Leave the drain cocks open until the mixture of water and cleaning agent has reached the respective drain.
- Close the drain cocks.
- Set all the water taps to "Hot" and open them.
- Leave the water taps open until the mixture of water and cleaning agent has reached the drain.
- Set all water taps to "Cold" and open them.
- Leave the water taps open until the mixture of water and cleaning agent has reached the drain.
- Close all water taps.
- Flush the toilet several times.
- Allow the cleaning agent to act in accordance with the manufacturer's instructions.
- Empty the water system. Collect the mixture of water and cleaning agent for correct disposal.
- For rinsing fill the entire water system with drinking water and empty again several times over.

### 11.5.3 Disinfecting the water system



- ▷ Only use suitable disinfectants as sold by the specialist trade.
- ▷ The disinfectant must meet national regulations and be approved (if required).



- ▷ Collect any emerging mixture of water and disinfectant for correct disposal.

When disinfecting the water system, proceed the same way as when cleaning the water pipes (see section 11.5.2). Simply use disinfectant instead of cleaning agent.

### 11.5.4 Cleaning the waste water tank

Clean the waste water tank after every use.

- Empty the waste water tank.
- Open the cleaning opening on the waste water tank and the drain cock.
- Thoroughly rinse out the waste water tank with fresh water.
- If possible, clean waste water sensors through the cleaning opening by hand.

## 11.6 Winter care

De-icing salt damages the underbody and the parts open to water spray. We recommend that you wash the vehicle more frequently during wintertime. Mechanical and surface treated parts and the underside are under particular strain, and should therefore be cleaned thoroughly.



- ▷ If there is any risk of frost, always run heater at a minimum of 15 °C. Switch the circulation fan to automatic. In the case of extreme external temperatures, the furniture flaps and doors should be left slightly open. The inflowing warm air can help prevent the freezing of water pipes, for example, and counteract the formation of condensation in the storage spaces.
- ▷ If there is any risk of frost, cover the outside surface of the windows with winter insulation mats.

## 11.7 Lay-up

### 11.7.1 Temporary lay-up





- ▶ If the vehicle has been stationary for a long period (approx. 10 months) have the braking and gas systems checked by an authorised specialist workshop.
- ▶ Take into consideration that water is undrinkable after only a short time.
- ▶ Animal damage to cables can lead to short circuits. Fire hazard!

Animals (especially mice) can cause great damage to the interior of the vehicle. This is especially true if the animal remains undisturbed in a parked vehicle.

To keep damages from animals to a minimum or to avoid them altogether, regularly check the vehicle for damage or animal traces.

If animal traces are found, contact the authorised dealer or service centre. If damage to cables has occurred, they can result in short circuits. The vehicle could catch fire.

Before laying up the vehicle, go through the following checklist:

	Activities	Done
<b>Base vehicle</b>	Completely fill fuel tank. This prevents corrosion damage within the fuel tank system	
	Jack up vehicle so that the wheels do not bear any load, or move vehicle every 4 weeks. This prevents any pressure points from occurring on tyres and wheel bearings	
	Protect the tyres from direct exposure to the sun. Danger of formation of cracks!	
	Inflate tyres up to the recommended maximum pressure	
	Always provide for sufficient ventilation in the underbody area	
	 ▷ Humidity or lack of oxygen e.g. by covering with plastic film may cause optical irregularities to the underbody.	
	In addition observe the notes in the operating manual of the base vehicle	
<b>Body</b>	All vents should be sealed with the appropriate caps and all other openings (apart from forced ventilations) should also be sealed. This prevents animals (e.g. mice) from gaining entry	
	Air the interior, all storage spaces accessible from the outside, and the parking space (e.g. garage) every 3 weeks in order to prevent the occurrence of condensation and resulting mould formation	
<b>Interior</b>	Place upholstery in an upright position for ventilation, and cover	
	Clean refrigerator	
	Allow refrigerator and freezer compartment doors to remain slightly open	
	Search for traces of animals that have gained entry	
	Disconnect the flat screen from the mains and, if necessary, remove it from the vehicle	
<b>Gas system</b>	Close regulator tap on the gas bottle	
	Close all gas isolator taps	
	Always remove gas bottles from the gas bottle compartment, even if they are empty	
<b>Electrical system</b>	Fully charge living area and starter battery	
	 ▷ Charge the battery for at least 20 hours before laying up.	
	Disconnect the living area battery from the 12 V power supply	
<b>Water system</b>	Empty the entire water system. Blow out the residual water from the water pipes (0.5 bar max.). Leave the water taps on in central position. Leave the safety/drainage valve and all drain cocks open. Observe notes in chapter 10	



**11.7.2 Winter lay-up**

Additional measures are required if laying up the vehicle over winter:

	<b>Activities</b>	<b>Done</b>
<b>Base vehicle</b>	Clean body and underbody thoroughly and spray with hot wax or protect with varnish	
	Fill fuel tank with winter diesel	
	Check antifreeze in the cooling water	
	Rectify damage to the paintwork	
	Fill in washer fluid with frost protection	
<b>Body</b>	Clean vehicle from outside thoroughly	
	Keep the forced ventilation open	
	Clean and grease all door and flap hinges	
	Brush oil or glycerine on all locking mechanisms	
	Treat all rubber seals with a conventional rubber care product	
	Use graphite dust to treat locking cylinders	
<b>Interior</b>	Set up the de-humidifier (granulate)	
	Remove cushions and mattresses from the vehicle and store them in a dry place	
	Air the interior every 3 weeks	
	Empty all cabinets and storage compartments, open flaps, doors and drawers	
	Thoroughly clean the interior	
	If there is a risk of frost, do not leave the flat screen in the vehicle	
<b>Electrical system</b>	Remove the starter battery and the living area battery and store them in a place protected from frost (see chapter 8) or connect the vehicle to a 240 V supply	
<b>Water system</b>	Clean the water system using a cleaning agent from a specialised store	
<b>Complete vehicle</b>	Arrange the tarpaulins in such a way that the ventilation openings are not covered, or use porous tarpaulins	

### 11.7.3 Starting up the vehicle after a temporary lay-up or after lay-up over winter

Go through the following checklist before start-up:

	Activities	Done
<b>Base vehicle</b>	Check the tyre pressure on all tyres	
	Check the tyre pressure of the spare wheel	
<b>Body</b>	Clean the pivot bearing of the entrance step	
	Check that the doors, windows and skylights are working properly	
	Check the function of the elevating roof	
	Check the function of all external locks	
	Remove the cover from the waste gas vent of the heater (if there is one)	
	Remove the winter cover from the refrigerator grills (if there is one)	
<b>Gas system</b>	Put the gas bottles in the gas bottle compartment, tie down and connect to the gas pressure regulator	
<b>Electrical system</b>	Connect to 240 V power supply using the external socket	
	Fully charge living area and starter battery	
	 ▷ Charge the battery for at least 20 hours after lay-up.	
	Connect the living area battery with the 12 V power supply (see chapter 8)	
	Check that the electrical system are working, e.g. interior light, socket and all installed electrical appliances	
<b>Water system</b>	Disinfect water pipes and water canister or water tank	
	Check the functionality of the operating lever for the waste water tank	
	Close safety/drainage valve, drain cocks and water taps	
	Check water system for leaks	
<b>Appliances</b>	Check the function of the refrigerator	
	Check the function of the heater/boiler	
	Check the function of the gas cooker	
	Check the function of the air conditioning unit	

## Chapter overview

This chapter contains instructions about inspection and maintenance work concerning the vehicle.

At the end of the chapter you will find important instructions on how to obtain spare parts and on our dealers and service centres.

### 12.1 Inspection work

Like any technical appliance, the vehicle must be inspected at regular intervals.

This inspection work must be carried out by qualified personnel.

Special technical knowledge, which cannot be taught within the framework of this instruction manual, is required for these tasks. Personnel possessing this technical knowledge are available for assistance at all service centres. Their experience and regular technical instruction by the factory as well as equipment and tools guarantee expert and up-to-date inspection of the vehicle.

The service centre in charge will confirm the work performed.

Have chassis inspections confirmed in the chassis manufacturer's customer service booklet.



- ▷ Observe the inspections indicated by the manufacturer and have them carried out at the specified intervals. The value of the vehicle is thus preserved.
- ▷ The confirmation of the inspection work carried out serves as valid proof in the event of damage and guarantee claims.

### 12.2 Maintenance work

As with every machine, this vehicle requires maintenance. The extent and frequency of the maintenance work required depend on conditions of operation and use. More difficult operating conditions make it necessary to service the vehicle more often.

Have the base vehicle and the appliances serviced at the intervals specified in the corresponding instruction manuals.

### 12.3 Replacing bulbs, external



- ▶ Bulbs and light fittings can be extremely hot. Therefore, allow lights to cool down before changing bulbs.
- ▶ Store bulbs in a safe place inaccessible to children.
- ▶ Do not use any bulb that has been dropped or which shows scratches in its glass. The bulb might burst.



- ▷ A new bulb should not be touched with the fingers. Use a cloth when installing the new bulb.
- ▷ Only use bulbs of the same type and with the correct wattage.
- ▷ If LEDs in lights are defect, contact an authorised dealer or service centre.

The exterior lighting is part of the base vehicle. Replacement of light bulbs is described in the instruction manual of the base vehicle.

The rear lights are not directly accessible. Fittings must be removed first so that the bulbs can be replaced.

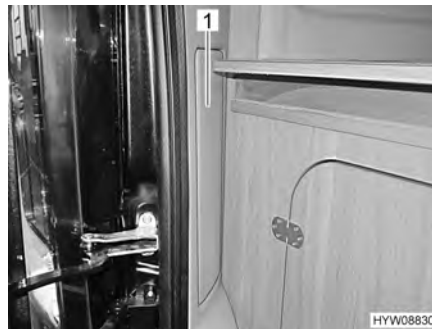

Fig. 115 Access to rear lights (Fiat)

*Right and left sides of the vehicle:*

- Remove the cover (Fig. 115,1). The cover is secured with Velcro.
- Change the bulb.

### 12.4 Lighting for living area

All of the lights in the living area are equipped with LED technology.

LED lights are economical, low-maintenance and have a very long life. It is not normally necessary to replace a light.



- ▷ If LEDs in lights are defect, contact an authorised dealer or service centre.

### 12.5 Changing the battery of the smoke alarm

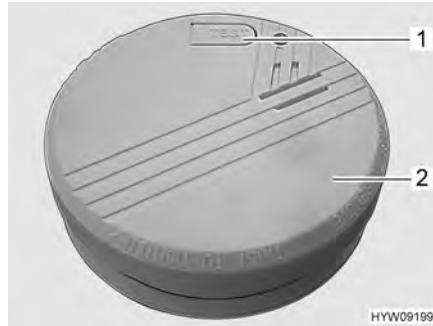

Fig. 116 Smoke alarm

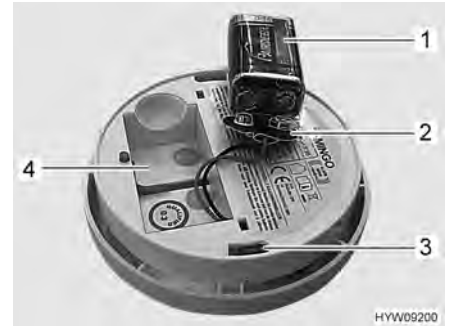

Fig. 117 Smoke alarm (rear side)

*Changing the batteries:*

- Turn the smoke alarm (Fig. 116,2) anticlockwise until it can be released from the holder.
- Remove the smoke alarm.
- Remove the battery and disconnect it from the battery clip (Fig. 117,2).
- If present: Remove the protective film from the new battery.
- Connect the new battery (Fig. 117,1) at the battery clip (Fig. 117,2). When doing so, make sure that the battery poles engage on the battery clip.
- Place the battery into the battery compartment (Fig. 117,4).



Fig. 118 Fit the smoke alarm

- Place the smoke alarm (Fig. 118,1) onto the holder (Fig. 118,3). The holding lugs (Fig. 118,2) must engage in the openings (Fig. 117,3) in the smoke alarm.
- Turn the smoke alarm clockwise until it engages.
- Test the smoke alarm. To do this, press the test button (Fig. 116,1). The alarm must sound.



- ▷ Replace the smoke alarm after 8 years.
- ▷ Change the smoke alarm battery regularly (no later than when the warning tone sounds to indicate that the battery is almost flat).
- ▷ Further information can be obtained in the device manufacturer's instruction manual.

## 12.6 Spare parts



- ▶ Every alteration of the original condition of the vehicle can alter road behaviour and jeopardize road safety.
- ▶ The special equipment and original spare parts recommended by us have been specially developed and supplied for your vehicle. These products are available at the authorised dealer or service centre. The authorised dealer or service centre is informed about admissible technical details and carries out the required work correctly.
- ▶ The use of accessories, parts and fittings not supplied by us may cause damage to the vehicle and jeopardize road safety. Even if an expert's report, a general type approval or a design certification exists, there is no guarantee for the proper quality of the product.
- ▶ No liability can be assumed for damage caused by products which have not been released by us. This also applies to impermissible alterations to the vehicle.

For safety reasons, spare parts for pieces of equipment must correspond with manufacturer's instructions and be permitted by the manufacturer as a spare part. These spare parts may only be fitted by the manufacturer or an authorised specialist workshop. The authorised dealers and service centres are available for any spare parts requirement.

Here are some suggestions of important spare parts:

- Fuses
- Bulbs
- Water pump (submerged pump)

When ordering spare parts, please indicate the serial number or the chassis number and the vehicle type to the dealer.

The vehicle described in this instruction manual is built and equipped to factory standards. Special equipment is offered depending on its purpose or use. When fitting special equipment check if such equipment has to be entered in the vehicle documents. Observe the max. permissible gross weight. The authorised dealer or service centre will be happy to advise you.

## 12.7 Vehicle identification plate

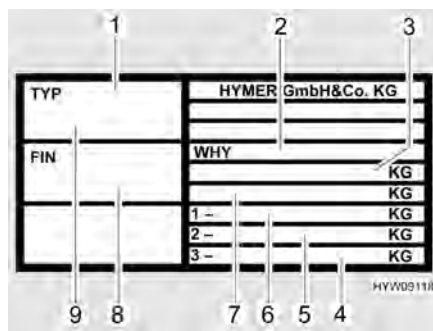

- 1 Type
- 2 Manufacturer's code and chassis number
- 3 Maximum permissible gross weight of the vehicle
- 4 Free
- 5 Permissible axle load rear
- 6 Permissible axle load front
- 7 Maximum permissible gross weight of the vehicle with trailer
- 8 Base vehicle chassis number
- 9 Serial number

Fig. 119 Vehicle identification plate

The vehicle identification plate (Fig. 119) with the serial number is attached on the right hand driver's cabin door.

Do not remove the vehicle identification plate. The vehicle identification plate:

- Identifies the vehicle
- Helps with the procurement of spare parts
- Together with the vehicle documents identifies the vehicle owner



- ▷ Always include the **serial number** with all inquiries for the customer service office.

## 12.8 Warning and information stickers

There are warning and information stickers on and inside the vehicle. Warning and information stickers are for the sake of safety and must not be removed.



- ▷ Replacement stickers can be obtained from an authorised dealer or a service centre.

## 12.9 Dealers

Contact your authorised dealer or service centre whenever spare parts are needed for the vehicle.

You can find the addresses and telephone numbers of the authorised dealers and service centres:

- In the brochure, which is included separately with the vehicle
- On the web at the homepage of the manufacturer

## 12.10 Replacement keys

To order replacement keys make a note of the following:

Locks for:	To order keys you need:	Obtainable at:	Telephone information:
Fiat base vehicle	Chassis number	Fiat authorised workshop	–
Mercedes-Benz base vehicle	Chassis number	Mercedes-Benz authorised workshop	–
Alarm system	Second key	Thitronik	+49 431 66668-0
Body	Serial number, chassis number, second key or key number	Dealers	–



## Chapter overview

This chapter contains instructions regarding the tyres of the vehicle.

At the end of the chapter there is a table you can use to find the correct tyre pressure for your vehicle.

### 13.1 General



- ▶ Check tyre pressure before a journey or every 2 weeks. Wrong tyre pressure causes excessive wear and can lead to damage or even to tyre burst. You can lose control of the vehicle (see section 13.6).



- ▷ Check the tyre pressure on cold tyres. Do not reduce the higher tyre pressure when the tyres are warm.
- ▷ Tubeless tyres have been installed on the vehicle. Never install tubes in these tyres.
- ▷ Read the instruction manual for the base vehicle.



- ▷ Depending on the model, the vehicle may only be equipped with a tyre repair kit as standard.
- ▷ In the case of a puncture, pull the vehicle over to the side of the road. Make vehicle safe with a hazard warning triangle. Switch on the warning lights.
- ▷ Tyres must not be older than 6 years as the material will become brittle over time. The four-digit DOT number (Fig. 120,1) on the tyre flank indicates the date of manufacture. The first two digits designate the week, the last two digits the year of manufacture.

Example: (3515) Week 35, year of manufacture 2015.



Fig. 120 DOT number

- Observe:**
- Check the tyres regularly (every 2 weeks) for equal tread wear, tread depth and external damage.
  - Replace tyres at the latest, when the minimum depth of tread stipulated by law is reached.
  - Always use tyres of the same model, same brand and same style (summer and winter tyres).
  - Only use tyres approved for the wheel rim type fitted. The permitted rim and tyre sizes are quoted in the vehicle documents and the authorised dealer or service centre will always be glad to give you advice.
  - Run-in new tyres for approx. 100 km (60 miles) at low speed since only then do they reach full strength.

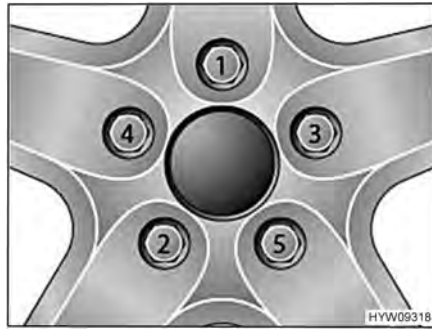

Fig. 121 Tightening the wheel nuts or wheel bolts cross-wise

- Tighten the wheel nuts or wheel bolts in the order shown in Fig. 121. In order to do this, use a torque wrench and comply with the specified tightening torque (see section 13.5.2).
- Check regularly that the wheel nuts or wheel bolts are firmly seated. Re-tighten the wheel nuts or wheel bolts of a changed wheel after 50 km. While doing so, proceed in the order shown in Fig. 121.
- When using new or newly painted rims, re-tighten the wheel nuts or wheel bolts once again after approx. 1,000 to 5,000 km (600 miles to 3,000 miles). While doing so, proceed in the order shown in Fig. 121.
- For lay-ups or long periods of inactivity, keep the tyres and tyre bearings free from pressure points:  
Jack up the vehicle so that the wheels do not bear any load, or move the vehicle every 4 weeks in such a way that the position of the wheels is changed.

## 13.2 Tyre selection



- ▶ A wrong tyre can damage the tyres during the journey and even cause it to burst.



- ▷ If tyres that are not approved for the vehicle are used, then the type approval for the vehicle and subsequently the insurance coverage can lapse. The authorised dealer or service centre will be happy to advise you.

The tyre sizes approved for the vehicle are given in the vehicle documents or can be obtained from the authorised dealers or service centres. Each tyre must fit the vehicle on which it will be driven. This applies to the external dimensions (diameter, width), which are indicated with the standardised size designations. In addition, the tyres must meet the requirements of the vehicle with regard to weight and speed.

Weight refers to the maximum permissible axle load which can be distributed on two tyres. The maximum load-carrying capacity of a tyre is indicated by its load index (= LI, load index code).

The axle geometry of a vehicle, such as wheel camber and track, is also important for tyre selection. The maximum permissible speed for a tyre (with full load-carrying capacity) is indicated by the speed index (= SI). Together, load index and speed index form the operating code of a tyre. This is an official component of the complete, standardised dimensions description which appears on every tyre. The information on the tyres must correspond to the specifications which appear in the vehicle papers.

### 13.3 Tyre specifications

**215/70 R 15C 109/107 Q  
(example)**

Description	Explanation
215	Tyre width in mm
70	Height-to-width proportion in percent
R	Tyre design (R = radial)
15	Rim diameter in inches
C	Commercial (transporter)
109	Load index code for single tyres
107	Load index code for twin tyres
Q	Speed index (Q = 160 km/h)

### 13.4 Handling of tyres

- Drive over kerbs at an obtuse angle. Otherwise the flanks of the tyres may get pinched. Driving over a kerb at a sharp angle can damage the tyre and result in it getting ruptured.
- Drive over high manhole covers at a slow speed. Otherwise the tyres may get pinched. Driving over a high manhole cover at high speed can damage the tyre and result in it getting ruptured.
- Check the shock absorbers regularly. Driving with poor shock absorbers significantly increases wear.
- If the tread wear is uneven, have the toe-in and the wheel camber checked. Driving with an incorrectly set toe-in or a one-sided wheel camber leads to a significant increase in wear.
- Do not clean the tyres with a high-pressure cleaner. The tyres can suffer serious damage within just a few seconds and rupture as a result.
- Drive in such a way as to protect your tyres. Avoid braking sharply, revving up too strongly and long journeys on poor roads.

## 13.5 Changing wheels

### 13.5.1 General instructions



- ▶ The vehicle must be on level, firm ground, secure from slipping.
- ▶ Go into first gear. In the case of automatic transmission, change gear to "P" position.
- ▶ Before jacking up the vehicle firmly apply the handbrake.
- ▶ Prevent the vehicle from rolling away by blocking the opposite wheel with the wheel chocks.
- ▶ Under no circumstances jack the vehicle with the fitted supports.
- ▶ If a trailer is connected: Detach the trailer before lifting the vehicle.
- ▶ Position the vehicle jack as specified for the basic vehicle or in line with the specifications of the frame manufacturer (AL-KO).
- ▶ Never overload the vehicle jack. The maximum permissible load is specified on the vehicle jack's identification plate.
- ▶ Use the vehicle jack only for lifting the vehicle briefly while changing the tyre.
- ▶ Do not start the motor while the vehicle is jacked up.
- ▶ Whilst the vehicle is in a jacked up position, persons must not lie down under it.



- ▷ Do not damage the thread of the thread bolt or wheel bolt when changing the wheel.
- ▷ Tighten the wheel nuts or wheel bolts cross-wise (Fig. 121).
- ▷ When changing wheels (e.g. alloy wheel rims or wheels with winter tyres), use the correct wheel bolts of the correct length and shape. Otherwise the wheels may not be securely fixed or the braking system may not work correctly.
- ▷ The use of wheel rims or tyres that are not approved for the vehicle can make it less than fully roadworthy; such wheel rims or tyres must be separately inspected and approved by an accredited test centre.
- ▷ Do not replace wheels cross-wise.



- ▷ Protect the vehicle according to the national regulations, e.g. with a hazard warning triangle.
- ▷ Before changing the wheel, check the wheel rim and tyre size, the max. tyre load and the speed index on the tyres. Only use the wheel rim and tyre sizes stated in the vehicle documents.
- ▷ The on-board tool set is adapted to the mounted wheel nuts or wheel bolts. When alloy wheel rims are mounted, carry an appropriate tool for the spare wheel (steel wheel rim) in the vehicle.
- ▷ Further information can be found in the instruction manual of the base vehicle.

**13.5.2 Tightening torque**

**Fiat base vehicle**

Wheel rim	Manufacturer	Tightening torque
Steel wheel rim	1)	1)
Alloy wheel rim 16" (chassis Light)	Borbet	140 Nm
Alloy wheel rim 17" (chassis Light)	Borbet	140 Nm
Alloy wheel rim 17" (chassis Maxi)	Borbet	140 Nm
Alloy wheel rim 18" (chassis Light)	Borbet	140 Nm
Alloy wheel rim 18" (chassis Maxi)	Borbet	160 Nm

**Mercedes-Benz base vehicle**

Steel wheel rim	1)	1)
Alloy wheel rim 16"	Mercedes-Benz	2)
Alloy wheel rim 17"	Mercedes-Benz	2)
Alloy wheel rim 18"	Borbet	180 Nm

- 1) Steel wheel rims are a component of the base vehicle. Please refer to the instruction manual of the base vehicle for information on the tightening torque of the steel wheel rims.
- 2) Alloy wheel rims are original Mercedes-Benz alloy wheels. Please refer to the instruction manual of the base vehicle for information on the tightening torque.

**13.5.3 Changing a wheel**



- ▶ The footplate of the vehicle jack must be levelly positioned on the ground.



- ▷ The wheel you have replaced should be repaired immediately.
  - ▷ Take note of the general instructions in this chapter.
- Park the vehicle on as even and stable a surface as possible.
  - Go into first gear. In the case of automatic transmission, change gear to "P" position.
  - Apply the handbrake.
  - Place chocks or other appropriate objects beneath the vehicle to secure it.
  - Remove the spare wheel from the spare wheel support.
  - If the ground is soft, place a stable support such as a wooden board beneath the vehicle jack.
  - Refer to the base vehicle's operating manual for the vehicle jack attachment point.
  - Using the wheel brace, turn the wheel bolts several times to loosen them, but do not remove them.
  - Lift the vehicle until the wheel has been lifted 2 to 3 cm above the ground.

- Remove the wheel bolts and take off the wheel.
- Place the spare wheel on the wheel hub and adjust.
- Screw in the wheel bolts and slightly tighten them cross-wise.
- Crank down the vehicle jack and remove it.
- Using the wheel brace, tighten the wheel bolts evenly (see section 13.5.2 for tightening torque).

#### 13.5.4 Changing a wheel with alloy wheel rims



- ▶ Alloy wheel rims and steel wheel rims require different wheel bolts. When alloy wheel rims are mounted, the spare wheel (steel wheel rim) is accompanied by suitable wheel bolts.

Wheels with alloy wheel rims are changed in the same way as wheels with steel rims (see section 13.5.3).

### 13.6 Tyre pressure



- ▶ Tyres overheat if the tyre pressure is too low. This can cause serious tyre damage.
- ▶ Check tyre pressure before a journey or every 2 weeks. Wrong tyre pressure causes excessive wear and can lead to damage or even to tyre burst. You can lose control of the vehicle.
- ▶ Use only valves that are approved for the specified tyre pressure.



- ▷ Check the tyre pressure on cold tyres. Do not reduce the higher tyre pressure when the tyres are warm.

The payload and the durability of tyres is directly dependent on the tyre pressure. Air is a volatile medium. It is unavoidable that it will escape from tyres. As a rule of thumb it can be assumed that a filled tyre loses pressure at a rate of 0.1 bar every two months. To prevent the tyres becoming damaged or burst, check the tyre pressure regularly.



- ▷ The information on pressure levels is valid for cold tyres and loaded vehicles.
- ▷ Pressure in hot tyres must be 0.3 bar higher than in cold tyres. Recheck the pressure when the tyres are cold.
- ▷ Tyre pressures in bar.
- ▷ Over 4.75 bar requires a metal valve.
- ▷ The tyre pressure tolerance is +/- 0.05 bar.
- ▷ For the maximum permissible axle loads for your vehicle please refer to specific documentation.
- ▷ Only the tyre inflation pressure values **in this instruction manual** apply even if the base vehicle manufacturer indicates other values.

The vehicles are constantly brought up to the newest technical standards. It is possible that new tyre sizes are not yet included in this table. If this is the case, any authorised dealer or service centre will be happy to provide the newest values.

**13.6.1 Tyre pressure**

**Fiat base vehicle**

Tyre size	Tyre manufacturer	Front air pressure (bar)	Rear air pressure (bar)
1)	-	-	-
225/75 R 16C 116/114 Q	All manufacturers	3.5	4
235/60 R 17C 117/115 R <sup>2)</sup>	All manufacturers	3.75	4.3
235/60 R 17C 117/115 R <sup>3)</sup>	All manufacturers	4.5	5.25
255/55 R 18C 116/114 T <sup>2)</sup>	All manufacturers	3.5	4
255/55 R 18C 116/114 T <sup>3)</sup>	All manufacturers	4.25	4.75

**Mercedes-Benz base vehicle**

4)	-	-	-
245/75 R 16LT 120 Q <sup>5)</sup>	All manufacturers	3.2	4.5
255/55 R 18C 116/114 T	All manufacturers	3.5	4.5

- 1) Please refer to the instruction manual of the base vehicle for information on the tyre pressure of the "Fiat tyres".
- 2) In the case of Chassis Light
- 3) In the case of Chassis Maxi
- 4) Please refer to the instruction manual of the base vehicle for information on the tyre pressure of the "Mercedes-Benz tyres".
- 5) Tyres on 16" steel wheel rim, only in the case of all-wheel drive

The tyre pressure data are applicable to the tyres offered as special equipment by **HYMER**.





## Chapter overview

This chapter contains instructions about possible faults in your vehicle. The faults are listed with their possible causes and corresponding remedies. The specified faults can be remedied with relative ease and without a great deal of specialised knowledge. In the event that the remedies detailed in this instruction manual should not be successful, an authorised specialist workshop must find and eliminate the cause of the fault.

### 14.1 Braking system



- ▶ Have defects on the braking system immediately remedied by an authorised specialist workshop.

### 14.2 Electrical system



- ▷ When the living area battery is changed, only use batteries of the same type and the same capacity.



- ▷ See chapter 8 for changing the fuses.

Fault	Cause	Remedy
Interior lighting does not work	LED lamp or cable defective	Contact customer service
	Fuse on the transformer/rectifier is defective	Replace fuse on the transformer/rectifier
The electrically operated entrance step cannot be moved in or out	Fuse on the transformer/rectifier is defective	Replace fuse on the transformer/rectifier
No 240 V power supply despite connection	240 V automatic circuit breaker has triggered	Switch on the 240 V automatic circuit breaker
Starter or living area battery is not charged when operated in 240 V mode	Jumbo flat fuse (40 A) on the starter or living area battery is defective	Replace jumbo flat fuse (40 A) on the starter or living area battery
	Charger module in the transformer/rectifier is defective	Contact customer service
Living area battery is not charged during vehicle operation	Fuse on terminal D+ of the alternator is defective	Replace fuse
	Disconnecter relay in the transformer/rectifier is defective	Contact customer service

Fault	Cause	Remedy
12 V indicator lamp does not light up	12 V power supply switched off	Switch 12 V power supply on
	Living area battery disconnected from the 12 V power supply	Connect the living area battery with the 12 V power supply
	Starter or living area battery is not charged	Charge the starter or living area battery
	Disconnecter relay in the transformer/rectifier is defective	Contact customer service
12 V power supply does not work	12 V power supply switched off	Switch 12 V power supply on
	Living area battery disconnected from the 12 V power supply	Connect the living area battery with the 12 V power supply
	Living area battery is discharged	Charge the living area battery
	Jumbo flat fuse (40 A) on the living area battery is defective	Replace jumbo flat fuse (40 A) on the living area battery
	Disconnecter relay in the transformer/rectifier is defective	Contact customer service
12 V power supply does not work in 240 V operation	12 V power supply switched off	Switch 12 V power supply on
	Living area battery disconnected from the 12 V power supply	Connect the living area battery with the 12 V power supply
	Charger module in the transformer/rectifier is defective	Contact customer service
	240 V automatic circuit breaker has triggered	Contact customer service
	Jumbo flat fuse (40 A) on the living area battery is defective	Replace jumbo flat fuse (40 A) on the living area battery
Starter battery is discharged in 12 V operation	Disconnecter relay in the transformer/rectifier is defective	Contact customer service
	Living area battery disconnected from the 12 V power supply	Connect the living area battery with the 12 V power supply

Fault	Cause	Remedy
No voltage is supplied by the living area battery	Living area battery is discharged	Charge living area battery immediately   ▷ Total discharge damages the battery.  If the vehicle is to be laid up for a long period, fully charge the living area battery beforehand
Living area battery overloaded ("hot")	Battery selection switch set wrongly	Move position of battery selection switch
	Defective load sensor or relay	Remove the jumbo flat fuse on the living area battery, then contact customer service

**14.3 Gas system**



- ▶ In case of a defect of the gas system (gas odour, high gas consumption) there is danger of explosion! Close regulator tap on the gas bottle immediately. Open doors and windows and ventilate well.
- ▶ If the gas system is defective: Do not smoke; do not ignite any open flames, and do not operate electric switches (light switches etc.). Check the tightness of gas-conducting parts and lines with leakage search spray. Do not check with an open flame.
- ▶ Have the defective gas system repaired by an authorised specialist workshop.

Fault	Cause	Remedy
No gas	Gas bottle is empty	Change gas bottle
	Gas isolator tap closed	Open the gas isolator tap
	Regulator tap on the gas bottle is closed	Open regulator tap on the gas bottle
	External temperature is too low (-42 °C for propane gas, 0 °C for butane gas)	Wait for higher external temperatures
	Built-in appliance is defective	Contact customer service

### 14.4 Gas cooker/gas oven

Fault	Cause	Remedy
Ignition fuse does not operate (flame does not burn after the control knobs are released)	Heat-up time is too short	Keep control knob pressed for approx. 15 to 20 seconds after ignition
	Ignition fuse is defective	Contact customer service
Flame extinguishes when being reduced to its minimum setting	Thermocouple sensor is incorrectly set	Correctly reset thermocouple sensor (do not bend). The sensor tip should protrude by 5 mm beyond the burner. The sensor neck should not be more than 3 mm away from the burner ring; if necessary, contact customer service

### 14.5 Heater/boiler

In the event of a defect contact the nearest customer service workshop of the relevant appliance manufacturer. The list of addresses is enclosed with the accompanying appliance documentation. Only authorised qualified personnel may repair the appliance.

#### 14.5.1 Truma heater/boiler with operating unit CP plus

Fault	Cause	Remedy
Heater does not ignite	Temperature sensor on operating unit or remote sensor defective	Pull out plug on operating unit. The heater then works without thermostat. Contact the customer service as soon as possible
No display on the operating unit	Fuse on the transformer/rectifier is defective	Replace fuse on the transformer/rectifier
	Fuse in the electronic control unit has been triggered	Contact customer service
	Living area battery defective	Charge or replace the living area battery (or have it charged or replaced)
Fault with error code is displayed	See table "Fault search instruction"	See table "Fault search instruction"
Boiler empties, safety/drainage valve has opened	Internal temperature below 8 °C	Heat inside
Safety/drainage valve cannot be closed	Temperature at safety/drainage valve below 8 °C	Heat inside
Fan wheel runs noisily or not steadily	Fan wheel is soiled	Contact Truma service department

**Fault search instruction**

<b>Error code</b>	<b>Cause</b>	<b>Rectification</b>
# 17	Summer operation with empty water container	Switch off the device and allow it to cool down. Fill the boiler with water
	Warm air louvres blocked	Check outlet openings
	Air circulation suction system blocked	Remove blocking of air circulation suction system
# 18	Gas pressure regulator iced up	Use regulator heater (defroster if available)
	Proportion of butane gas in gas bottle too high	Use propane gas (butane gas is unsuitable for heating especially for temperatures under 10 °C)
# 21	Room temperature sensor or cable defective	Contact customer service
# 24	Risk of undervoltage Battery voltage too low < 10.4 V	Charge the battery
# 29	Short circuit in heating element for frost control	Remove plug of heating element on electronic control unit. Replace heating element
# 41	Electronics blocked	Contact customer service
# 42	Safety switch has triggered	(Not used here)
# 43	Overvoltage > 16.4 V	Check battery voltage and voltage sources (e.g. charging unit)
# 44	Undervoltage Battery voltage too low < 10.0 V	Charge battery. Replace outdated battery if required
# 45	No 240 V power supply	Check external mains connection
	240 V automatic circuit breaker has triggered	Switch on the 240 V automatic circuit breaker
	Overheating protection has triggered	Reset overheating protection. Allow heater to cool, remove connection cover and press reset button
#112, #202, #121, #211	Lack of gas	Open regulator tap and gas isolator tap
		Connect a full gas bottle
#122, #212	Combustion air inlet or exhaust gas outlet closed	Check openings for dirt (slush, ice, leaves etc.) and clean if necessary
#255	No connection between heater and operating unit	Contact customer service
	Cable defective	Contact customer service

## 14.6 Truma boiler



- ▷ In the case of faults that are not mentioned herein, contact the customer service.

Fault	Cause	Remedy
Boiler is not working	No supply voltage	Check battery
		Check fuse
		Connect vehicle to external power supply
	Window open	Close window above the chimney
	Overheating protection active	Check if boiler is filled with water; refill water if necessary
Switch boiler off, wait 10 minutes; switch boiler on again		
Too slow heating in "low output" position	Contact customer service	
Boiler is not working, red LED lights up after approx. 30 seconds	Chimney cap put on	Remove chimney cap and/or check for dirt
	No gas supply	Check gas isolator tap and gas bottle
	Wrong gas pressure	Check gas isolator tap and gas bottle
	Air in the gas pipe	Switch boiler off, wait 5 minutes; switch boiler on again
Red LED is lit after long operation period	Overheating protection active	Check if boiler is filled with water; refill water if necessary
		Switch boiler off, wait 5 minutes; switch boiler on again
Water is dropping out of the drain cock	Water pressure too high	Check water pressure (max. 2.8 bar)
		If connected to an external water supply: connect a pressure reducer

**14.7 Air conditioning unit**



- ▷ Cooling with the air conditioning unit is possible at ambient temperatures of between 16 °C and 52 °C.
- ▷ Heating with the air conditioning unit is possible at ambient temperatures of between 2 °C and 30 °C.

<b>Fault</b>	<b>Cause</b>	<b>Remedy</b>
Air conditioning unit continually switches itself off	Icing sensor has triggered	Outside temperature too low or all air nozzles are closed
No cooling power	Air conditioning unit is not set to cooling	Set air conditioning unit to cooling
	Ambient temperature is above 52 °C	-
	Set temperature is higher than room temperature	Select a lower temperature
	Ambient temperature is below 16 °C	-
	One of the temperature sensors is faulty	Contact customer service
	Evaporator fan is defective	Contact customer service
	Condenser fan is defective	Contact customer service
No heating power	Ambient temperature is above 30 °C	-
	Ambient temperature is below 2 °C	-
	Set temperature is higher than 30 °C	Select a lower temperature
	Air conditioning unit is not set to heating	Set air conditioning unit to heating
	One of the temperature sensors is faulty	Contact customer service
Poor air performance	Air intake is blocked	Remove leaves and other dirt from the ventilation fins on the air conditioning unit regularly
	Fan is defective	Contact customer service
Water entering the vehicle	Drainage openings for condensation are blocked	Clean drainage openings for condensation
	Seals defective	Contact customer service

Fault	Cause	Remedy
Air conditioning unit does not cut in	No supply voltage (230 V) present	Check power supply
	Voltage is too low (less than 200 V), transformer is defective	Contact customer service
	One of the temperature sensors is faulty	Contact customer service
	Electrical protection for the power supply insufficient	Check the electrical protection for the power supply
Air conditioning unit does not switch off	One of the temperature sensors is faulty	Contact customer service
	Electrical protection for the power supply insufficient	Check the electrical protection for the power supply

## 14.8 Refrigerator

In the event of a defect contact the nearest customer service workshop of the relevant appliance manufacturer. The list of addresses is enclosed with the accompanying appliance documentation. Only authorised qualified personnel may repair the appliance.

### 14.8.1 Thetford T1000

Fault	Cause	Remedy
Refrigerator is not cooling, compressor is not running at all	Battery voltage too low	Charge the battery
	Start delay of 1 minute (not an error)	Wait 1 minute
	Ambient temperature is too high	Switch refrigerator off for 1 hour; ventilate the vehicle; switch off the night mode
	Fuse is defective	Replace fuse on the transformer/rectifier
Freezer compartment does not reach freezing temperature	Ambient temperature below 16 °C	Increase temperature in the living area and/or select higher cooling level
Refrigerator does not cool, compressor starts but switches off immediately	Ambient temperature is too high	Switch refrigerator off for 1 hour; ventilate the vehicle; switch off the night mode
Refrigerator is cooling too intensely	Set cooling level is too high	Set lower cooling level
Operating noises higher than in night mode	Refrigerator is working in normal mode	Change to night mode (only if temperature is below 30 °C)
Refrigerator is not cooling, compressor is running permanently	Fault in the refrigerator	Contact customer service



Fault	Cause	Remedy
Refrigerator does not refrigerate sufficiently	Ambient temperature is too high	Switch refrigerator off for 1 hour; ventilate the vehicle; switch off the night mode
	Ventilation opening entirely or partially obstructed	Remove obstruction
	Refrigerator door not closed correctly	Close refrigerator door, check gasket
	Vaporiser heavily iced-over (ice layer thicker than 3 mm)	Defrost vaporiser, check gasket

**14.8.2 Cruise 85**

Fault	Cause	Remedy
Refrigerator does not work	Refrigerator is turned off	Switch on refrigerator
	Electrical operating voltage too low or not present	Connecting the 240 V power supply
		Let the vehicle engine run
		Check fuse, replace if necessary
	Contact a specialist workshop	
	Thermostat defective	Contact customer service
Electronic control defective	Contact customer service	
Interior lighting does not work	Refrigerator is turned off	Switch on refrigerator
	Bulb is defective	Changing the bulb
Refrigerator does not cool properly although the compressor runs for a long time	Temperature controller set too low	Adjust the temperature controller
	Ambient temperature is too high	Improve ventilation
	Too much ice on the cooling fins	Defrost the refrigerator
	Fan is defective	Contact a specialist workshop
	Door does not close properly	Check door and seal; if necessary, contact customer service
Compressor is running continuously	Thermostat defective	Contact customer service
Operating noises too loud	Nearby furniture vibrates	Check the attachment or straighten the refrigerator
The fuse blows	Wrong fuse	Replace fuse
	Electronic control defective	Contact customer service

## 14.9 Water supply

Fault	Cause	Remedy
Leakage water inside the vehicle	A leak has occurred	Identify leak, re-connect water pipes
No water	Water tank is empty	Replenish drinking water
	Drain cock not closed	Close drain cock
	12 V power supply is switched off	Switch 12 V power supply on
	Fuse of the water pump is defective	Replace fuse on the transformer/rectifier
	Water pump defective	Exchange water pump (have it exchanged)
	Water pipe snapped off	Straighten water pipe or replace
	Transformer/rectifier defective	Contact customer service
Toilet has no flush water	Water tank is empty	Replenish drinking water
Display for water and waste water indicates a wrong value	Measuring probe in the waste water or water tank is soiled	Clean water/waste water tank
	Measuring probe is defective	Replace measuring probe
Waste water tank cannot be emptied	Drain cock is clogged	Blow out the waste water tank and drainage pipe. Rinse the waste water tank well
Drain on the single lever mixer tap is clogged	Perlator calcified	Unclip the perlator, de-calcify in vinegar water (only for products made from metal)
Water jets on the shower nozzle clogged	Water jets calcified	De-calcify shower nozzle in vinegar water (only for products made from metal) or rub off soft nozzle burling
Water drains from the shower tray slowly or does not drain at all	The vehicle is not in a horizontal position	Position the vehicle horizontally
Milkiness of the water	Tank filled with dirty water	Clean water tank mechanically and chemically; then disinfect and rinse copiously with drinking water
	Residues in the water tank or water system	Clean water system mechanically and chemically; then disinfect and rinse copiously with drinking water

Fault	Cause	Remedy
Any change in the taste or odour of the water	Tank filled with dirty water	Clean water system mechanically and chemically; then disinfect and rinse copiously with drinking water
	Fuel filled into the water tank by mistake	Clean water system mechanically and chemically; then disinfect and rinse copiously with drinking water. If not successful: Contact a specialist workshop
	Microbiological deposits in the water system	Clean water system mechanically and chemically; then disinfect and rinse copiously with drinking water
Deposits in the water tank and/or water-carrying components	Water excessively long in the water tank and in water-carrying components	Clean water system mechanically and chemically; then disinfect and rinse copiously with drinking water

**14.10 Body**

Fault	Cause	Remedy
Flap hinges/door hinges are difficult to operate	Flap/door hinges are not sufficiently lubricated	Lubricate flap hinges/door hinges with acid-free and resin-free grease
Hinges/joints in the bathroom unit/toilet compartment are difficult to operate/make a grating noise	Hinges/joints are not sufficiently lubricated	Lubricate hinges/joints with solvent-free and acid-free grease  ▷ Spray cans often contain solvents
Storage compartment hinges are difficult to operate/make a grating noise	Storage compartment hinges are not sufficiently lubricated	Lubricate storage compartment hinges with acid-free and resin-free grease
Elevating roof difficult to move	Gas-pressure spring or lifting scissors are defective	Contact customer service



▷ The authorised dealers and service centres are available for any spare parts requirement.



## 15.1 Weight details for special equipment



- ▶ The use of accessories, parts and fittings not supplied by us may cause damage to the vehicle and jeopardize road safety. Even if an expert's report, a general type approval or a design certification exists, there is no guarantee for the proper quality of the product.
- ▶ Every alteration of the original condition of the vehicle can alter road behaviour and jeopardize road safety.
- ▶ No liability can be assumed for damage caused by products which have not been released by us. This also applies to impermissible alterations to the vehicle.

Weight details for special equipment available from the manufacturer are listed in the table below. If these objects are either carried in or on the vehicle and are not part of the standard equipment, they must be taken into consideration when calculating the payload.

All weight details are approximate.

Observe the max. permissible gross weight.

The table shows an extract from the list of possible special equipment and the surplus weight in each case.

Item designation	Surplus weight (kg)
Alloy wheel rims 16"	-2
Alloy wheel rims 17"	10
Hitch	27
Elevating roof	100
Entrance step, electrical	8
Air conditioning unit	30
Awning	28-40
TV unit	9
Second living area battery	30



## 16.1 Technical data



- ▷ Only the details provided in the actual vehicle documentation shall be binding with regard to the technical data.
- ▷ The measurements as well as the net weight of the vehicle may change when mounting accessories or special equipment. Differences due to manufacturing tolerances (+/- 5 %) are possible and admissible.

Further information can be found in the manual of the base vehicle. The technical data are not a component of the instruction manual.

The technical data can be obtained from the manufacturer's documentation. Alternatively, the authorised dealer or service centre will also be happy to advise you.





12 V appliance, retrofitting . . . . . 85  
 12 V fuses . . . . . 90  
     For the Thetford toilet . . . . . 91  
     On the living area battery . . . . . 91  
     On the relay box AD01 . . . . . 91  
     On the starter battery . . . . . 90  
     On the transformer/rectifier (EBL 30) . . . . . 91  
 12 V main switch . . . . . 86  
 12 V power supply . . . . . 78  
     Switching on . . . . . 86  
     Troubleshooting . . . . . 162  
 240 V connection . . . . . 43, 89  
     Troubleshooting . . . . . 161  
 240 V fuse . . . . . 92  
 240 V fuse box . . . . . 92  
 240 V power supply . . . . . 88

**A**

AC converter . . . . . 82  
 Accessories, fitting . . . . . 16  
 Actual weight . . . . . 22  
 Additional equipment . . . . . 23  
 Add-on parts see special equipment . . . . . 16  
 Air conditioning unit . . . . . 104  
     Blind . . . . . 107  
     Ceiling unit . . . . . 106  
     Lighting . . . . . 107  
     Operating modes . . . . . 105  
     Remote control . . . . . 105, 107  
     Sleep function . . . . . 108  
     Switching off . . . . . 106  
     Switching on . . . . . 106  
     Timer . . . . . 108  
     Troubleshooting . . . . . 167  
 Air outlet nozzles, adjustment . . . . . 96  
 Alloy wheel rims . . . . . 158  
 Appliances . . . . . 95  
     Manuals . . . . . 16  
 Armrest, adjustment . . . . . 39  
 Awning . . . . . 43

**B**

Basic equipment . . . . . 22  
 Battery cut-off switch . . . . . 84  
 Battery monitor . . . . . 84  
 Battery see starter battery  
 or living area battery . . . . . 78, 80  
 Battery selector switch . . . . . 84

Battery, smoke alarm, changing . . . . . 149  
 Beds . . . . . 67  
 Before the journey . . . . . 21  
 Bike rack  
     Load . . . . . 27  
     Travelling with a loaded bike rack . . . . . 27  
 Blind, cleaning . . . . . 138  
 Blind, skylight with snap latch  
     Closing . . . . . 54  
     Opening . . . . . 54  
 Block diagram 240 V . . . . . 93  
 Boiler . . . . . 95, 97  
 Boiler (Truma)  
     Emptying . . . . . 100  
     Operating modes . . . . . 100  
     Safety/drainage valve . . . . . 99  
     Switching off hot water production . . . . . 99  
     Switching on hot water production . . . . . 99  
     Troubleshooting . . . . . 164  
     Water, filling with . . . . . 100  
 Boiler (Truma, separate) . . . . . 108, 109  
     Emptying . . . . . 110  
     Operating modes . . . . . 109  
     Troubleshooting . . . . . 166, 167  
     Water, filling with . . . . . 110  
 Brakes . . . . . 36  
     Check . . . . . 36, 161  
 Braking system, troubleshooting . . . . . 161  
 Bulbs, changing . . . . . 148  
 Bulbs, changing, exterior lighting . . . . . 148  
 Butane gas . . . . . 18, 72

**C**

Cable reel . . . . . 89  
 Camping gas bottles, use . . . . . 19, 73  
 Capacity of the battery . . . . . 78  
 Caravan coupling . . . . . 29  
     With detachable ball neck . . . . . 28  
 Caravan couplings . . . . . 28  
 Care . . . . . 133  
     Blind . . . . . 138  
     Carpet . . . . . 138  
     Curtains . . . . . 138  
     Engine compartment . . . . . 135  
     Entrance step . . . . . 137  
     External care . . . . . 133  
     Furniture surfaces . . . . . 138  
     GRP add-on parts . . . . . 134  
     High-pressure cleaner, washing with . . . . . 133

- In the winter ..... 143  
 Insect screen ..... 138  
 Interior care ..... 137  
 Kitchen installation ..... 138  
 Lamps ..... 138  
 Leather covers ..... 140  
 Net curtains ..... 138  
 PVC-floor covering ..... 138  
 Refrigerator ..... 139  
 Roman shade ..... 138  
 Seat belt ..... 138  
 Stainless steel surfaces ..... 139  
 Synthetic parts, interior ..... 138  
 Temporary lay-up ..... 143  
 Underbody ..... 135  
 Upholstery ..... 140  
 Washing ..... 134  
 Waste water tank ..... 143  
 Water pipes ..... 142  
 Water system ..... 141  
 Water tank ..... 141  
 Windows ..... 134  
 Windscreen washer system ..... 136  
 Windscreen wipers ..... 136  
 Winter lay-up ..... 145  
 Carpet, cleaning ..... 138  
 Checklist  
   Before the journey ..... 32  
   Initial start-up after temporary lay-up ..... 146  
   Road safety ..... 32  
   Start-up ..... 9  
   Temporary lay-up ..... 144  
   Winter lay-up ..... 145  
 Checks see checklist ..... 32, 144  
 Child restraint systems ..... 37  
 Circuit diagrams  
   12 V block diagram ..... 94  
   240 V block diagram ..... 93  
 Circulation fan ..... 97  
 Cleaning see care ..... 133  
 Cleaning, water tank ..... 141  
 Closed circuit current ..... 77  
 Condensation ..... 48, 49  
 Condensation on the  
   double acrylic glass pane ..... 49  
   Condensation on the  
   screwed connections in the floor ..... 48  
 Connecting cable see 240 V connection ..... 89  
 Conventional load ..... 23  
 Conversion door ..... 41, 47  
 Cruise 85, ventilation position ..... 117  
 Curtains, cleaning ..... 138  
 Customer service ..... 147
- ## D
- Danger of suffocation ..... 15, 48  
 Dealers ..... 152  
 Dimensions see technical data ..... 175  
 Disposal  
   Household waste ..... 12  
   Sewage ..... 12  
   Waste water ..... 12  
 Doors  
   Conversion door ..... 41, 47  
   Driver's door ..... 41, 47  
   Passenger's door ..... 41, 47  
   Troubleshooting ..... 171  
 Drain cocks, position ..... 131  
 Drinking water filler neck  
   Closing ..... 122  
   Opening ..... 122  
 Driver's door ..... 41, 47  
 Driver's seat ..... 38  
   Armrest, adjustment ..... 39  
   Backrest, adjustment ..... 39  
   Moving in lengthways direction ..... 39  
   Seat inclination, adjustment ..... 39  
   Turning it to driving position ..... 39  
 Driving speed ..... 35  
 Driving the motorhome ..... 35  
 During the journey ..... 35
- ## E
- Electrical system ..... 77  
   240 V connection, troubleshooting ..... 161  
   Entrance step, troubleshooting ..... 161  
   Explanation of terms ..... 77  
   Safety instructions ..... 20  
   Troubleshooting ..... 161  
 Elevating roof ..... 55  
   Troubleshooting ..... 171  
 Energy balance, living area battery ..... 82  
 Engine compartment, care ..... 135  
 Entrance step ..... 29, 43  
   Care ..... 137  
   Extending ..... 30  
   Retracting ..... 30



- Hinged window ..... 49  
 Closing ..... 50  
 Continuous ventilation ..... 50  
 Opening ..... 50  
 Hot air distribution ..... 96  
 Hot-air heater ..... 97  
 Circulation fan ..... 97  
 Operating modes ..... 100  
 Operating unit ..... 97, 103  
 Safety instructions ..... 102  
 Switching off ..... 104  
 Switching on ..... 104  
 Troubleshooting ..... 164
- I**
- Indicator lamp, toilet ..... 128  
 Information stickers ..... 151  
 Inner door, troubleshooting ..... 171  
 Insect screen, cleaning ..... 138  
 Insect screen, hinged skylight  
 Closing ..... 55  
 Opening ..... 55  
 Inspection work ..... 147  
 Inspections ..... 147  
 Interior care ..... 137  
 Interior lighting ..... 148  
 Troubleshooting ..... 161  
 Internet address ..... 1
- K**
- Kitchen area ..... 30
- L**
- Lamps ..... 148  
 Cleaning ..... 138  
 Lay-up  
 Temporary ..... 143  
 Temporary (toilet) ..... 131  
 Winter lay-up ..... 145  
 Leakage water inside the vehicle ..... 170  
 Leather covers, cleaning ..... 140  
 Light metal wheel rims  
 see alloy wheel rims ..... 158  
 Lighting  
 Bulbs, changing ..... 148  
 Lamps, cleaning ..... 138  
 Living area ..... 148
- Living area battery ..... 80  
 Charging ..... 81  
 Energy balance ..... 82  
 Fuses ..... 91  
 Instructions ..... 80  
 Troubleshooting ..... 161, 163  
 Load ..... 25  
 Bike rack ..... 27  
 Roof rack ..... 28  
 Load see also payload ..... 25  
 Lock, external flap ..... 47
- M**
- Maintenance ..... 147  
 Maintenance work ..... 147  
 Mass in ready-to-drive condition ..... 22, 24  
 Maximum permissible gross weight ..... 22, 24
- N**
- Net curtains, cleaning ..... 138  
 Nose weight ..... 28  
 Notification of delivery ..... 3
- O**
- Off-load voltage ..... 77  
 Operating modes, air conditioning unit ..... 105  
 Operating modes, boiler (Truma) ..... 100  
 Operating modes, boiler (Truma, separate) ..... 109  
 Operating modes, hot-air heater ..... 100  
 Operating modes, refrigerator ..... 113, 115  
 Operating unit, hot-air heater ..... 97  
 Oven see gas cooker or gas oven ..... 112  
 Overloading ..... 25
- P**
- Panel (LT 453) ..... 85  
 12 V main switch ..... 86  
 Panel see also displays ..... 85  
 Passenger's door ..... 41, 47  
 Payload ..... 21  
 Calculation ..... 24  
 Composition ..... 23  
 Example calculation ..... 22, 24  
 Payload see also load ..... 21  
 Permissible gross weight  
 see maximum permissible gross weight ..... 21

Personal equipment ..... 23  
 Propane gas ..... 18, 72  
 PVC-floor covering, cleaning ..... 138

**R**

Rear axle load ..... 28  
 Rear bed  
     Closing ..... 67  
     Opening ..... 67  
 Refrigerator ..... 43, 113, 115  
     Care ..... 139  
     Collection tray, emptying ..... 115  
     Defrosting ..... 115, 116  
     Door lock ..... 116  
     Night mode, switching off ..... 114  
     Night mode, switching on ..... 114  
     Operating modes ..... 113, 115  
     Switching off ..... 114, 116  
     Switching on ..... 114, 115  
     Temperature, adjusting ..... 114, 116  
     Troubleshooting ..... 168, 169  
 Refrigerator door  
     Closing ..... 117  
     Locking in the ventilation position ..... 117  
     Ventilation position ..... 117  
 Replacement keys ..... 152  
 Risk of frost damage ..... 20, 119, 124  
 Road safety ..... 32  
     Checklist ..... 32  
     Notes for ..... 16  
 Roman shade, cleaning ..... 138  
 Roman shade, driver's window ..... 40  
     Closing ..... 52  
     Opening ..... 52  
     Securing ..... 40  
 Roman shade, front passenger's window ..... 40  
     Closing ..... 52  
     Opening ..... 52  
     Securing ..... 40  
 Roman shade, hinged skylight  
     Closing ..... 55  
     Opening ..... 55  
 Roman shade, windscreen  
     Closing ..... 51  
     Opening ..... 52  
 Roof load ..... 28  
 Roof rack, load ..... 28

**S**

Safety instructions ..... 15  
     Electrical system ..... 20  
     Fire prevention ..... 15  
     Gas bottles ..... 72  
     Gas system ..... 18, 71  
     Heater ..... 102  
     Road safety ..... 16  
     Towing ..... 17  
     Water system ..... 20  
 Safety/drainage valve boiler ..... 99  
     Position ..... 100  
 Safety/drainage valve, position ..... 131  
 Sanitary fittings ..... 119  
 Satellite antenna, external ..... 65  
 Satellite unit, connecting ..... 65  
 Seat belts ..... 36  
     Cleaning ..... 138  
     Fastening correctly ..... 36  
 Seating arrangement ..... 40  
 Seats, rotating ..... 59  
 Serial number ..... 151  
 Service centres, directory ..... 1  
 Set of keys ..... 21  
 Sewage tank  
     Emptying ..... 129  
     Removing ..... 129  
 Shower ..... 126  
 Skylight with snap latch  
     Blind ..... 54  
     Closing ..... 53  
     Opening ..... 53  
 Skylights ..... 52  
 Smoke alarm ..... 66  
     Activating ..... 66  
     Battery, changing ..... 149  
     Testing ..... 66  
 Snow chains ..... 31  
 Spare parts ..... 150  
 Special equipment ..... 173  
     Description ..... 11  
     Marking ..... 11  
     Safety instructions ..... 16  
     Weight details ..... 173  
 Stainless steel surface, cleaning ..... 139



**W**

Warning stickers .....	151
Warning tone, entrance step .....	30
Warranty .....	3
Washing with a high-pressure cleaner .....	133
Waste water tank .....	125
Care .....	143
Emptying .....	125
Troubleshooting .....	170
Water pipes, cleaning .....	142
Water pump .....	119, 120
Water pump switch .....	86
Water supply	
General .....	119
Troubleshooting .....	170
Water system	
Care .....	141
Cleaning .....	141
Disinfecting .....	142
Emptying .....	124
Filling .....	120
Safety instructions .....	20
Water tank .....	120
Cleaning .....	141
Filling .....	122
Water quantity, reducing .....	123
Water, draining .....	123
Water, filling with .....	122
Weight details for special equipment .....	173
Wheel rim size .....	156
Wheel rim type .....	153
Wheels .....	153
Wheels, changing, with alloy wheel rims .....	158
Windows .....	48
Windows, cleaning .....	134
Windscreen washer system, care .....	136
Windscreen wipers, care .....	136
Winter care .....	143

