

Dear Customer,

We are pleased that you have chosen a motorhome from **HYMER** and would like to thank you for the trust you have shown in our company.

This instruction manual is intended to help you get to know and use your new motorhome. **It is essential that you read and comply with the safety instructions in chapter 2.**

Don't hesitate to contact our **HYMER** service centres if you have any questions. Their staffs are fully conversant with your vehicle and will be pleased to help in any way they can. Our list of **HYMER** service centres in Europe is updated regularly. You can obtain a copy of the latest edition from our customer service department or from your **HYMER** dealer.

In addition to this instruction manual, you are also receiving from us

- **the service folder containing all information about the inspection intervals and the water ingress tests,**
- **the separate instruction manuals for the base vehicle and the various appliances.**

We are sure that you will get a lot of enjoyment from your motorhome. Have a good trip!

You will also find **HYMER GmbH & Co. KG** on the Internet at: <http://www.hymer.com>

Yours, **HYMER GmbH & Co. KG**

Please also observe the chassis manufacturer's operating instructions at all times.

The terms used in these operating instructions with regard to weight specifications are explained again in detail at the end of the operating instructions (legal information on weight-related specifications). For further details on weight specifications, please also refer to the "Weight information" section of our homepage at www.hymer.com/de/en/weight-information.

Checklist before first journey of the vehicle.....	7	4.13	Ad-Blue®	43
		4.14	Towing	44
1 Introduction	9	5	Pitching the Motorcaravan	45
1.1 General	10	5.1	Entrance step	45
1.2 Environmental tips	10	5.2	Ramps	45
2 Safety	13	5.3	Wheel chock	45
2.1 Fire prevention	13	5.4	Supports	45
2.1.1 Avoidance of fire risks	13	5.4.1	General instructions	45
2.1.2 Fire-fighting	13	5.4.2	Mechanical steady legs	46
2.1.3 In case of fire	13	5.5	230 V connection	47
2.2 General	13	5.6	Refrigerator	47
2.3 Road safety	14	5.7	Awning, electrically operated (optional)	47
2.4 Towing	16	5.8	Rear wall	50
2.5 Gas system	16	5.8.1	Rear ladder	53
2.5.1 General instructions	16	5.8.2	Rear platform safety guard	54
2.5.2 Gas bottles	17	5.8.3	Camping chairs	56
2.6 Electrical system	18	5.8.4	Rear window	57
2.7 Water system	18	5.8.5	Insect screen / Darkening screen	58
3 Before the journey	19	5.9	Sleeping roof	59
3.1 Initial start-up	19	5.9.1	Shade	62
3.2 Vehicle load capacity	19	5.9.2	Temperature regulation in the sleeping roof	63
3.2.1 Terms	20	5.9.3	Shelf board	63
3.2.2 Calculating the vehicle load capacity	24	5.9.4	Safety guard protection	65
3.2.3 Load securing and load distribution	25	5.9.5	Sleeping roof air chamber repair	66
3.3 Towing	30	6	Living	67
3.4 Caravan coupling (optional)	30	6.1	Central locking system	67
3.5 Entrance step	31	6.2	Doors	67
3.6 Projector	31	6.2.1	Living area door, outside	68
3.7 Kitchen area	32	6.2.2	Electrical closing assist	68
3.8 Snow chains	32	6.2.3	RFID chip	69
3.9 Road safety	33	6.2.4	Living area door, inside	69
4 During the journey	35	6.2.5	Driver's door, outside	70
4.1 Driving	35	6.2.6	Insect screen on the living area door, extendable	70
4.2 Breakdown assistance in the event of vehicle-related technical problems	36	6.3	External flaps	71
4.3 Driving speed	37	6.3.1	Flap lock, rectangular	71
4.4 Brakes	37	6.4	Ventilation	72
4.5 Additional main beam	37	6.5	Windows	72
4.6 Seating arrangement	38	6.5.1	Hinged window with automatic hinges	73
4.7 Seat belts	39	6.5.2	Roman shade and insect screen	75
4.7.1 General	39	6.5.3	Roman shade for windscreen, driver's window and front passenger's window	76
4.7.2 Fastening the seat belts correctly	39	6.6	Skylights	76
4.8 Child restraint systems	40	6.6.1	Hinged skylight	77
4.9 Driver's seat and front passenger's seat	41	6.6.2	Skylight with fan (optional)	79
4.10 Reversing camera	42	6.7	Storage spaces	80
4.11 Roman shades for driver's window and front passenger's window	43	6.7.1	Furniture flaps with comfort push button	81
4.12 Refuelling	43	6.7.2	Service cover in the floor	81
		6.7.3	Multifunctional wall	82
		6.7.4	Underfloor installation compartment	82

6.8	Fixing rails on the roof (Airlines).....	83	9.3	Air conditioning unit Truma Saphir (optional).....	130
6.9	Tables.....	83	9.4	Hot air / cold air nozzles.....	133
6.9.1	Table in the living area.....	83	9.5	Cooker.....	134
6.9.2	Secretary, foldable.....	84	9.5.1	Gas cooker.....	134
6.9.3	Work top extension.....	87	9.6	Refrigerator.....	135
6.10	Lighting.....	89	9.6.1	Compressor refrigerator – General	135
6.10.1	Pendant light.....	90	9.6.2	Compressor refrigerator Vitrifrigo - Operation.....	136
6.10.2	Mobile reading lamp.....	91	9.6.3	Refrigerator door locking mechanism.....	136
6.10.3	Goose neck reading lamp on the secretary.....	91			
6.11	Conversion of seating group into additional bed.....	92			
7	Gas system.....	93	10	Sanitary fittings.....	137
7.1	General instructions.....	93	10.1	Water supply, general.....	137
7.2	Gas bottles.....	94	10.2	Water system.....	138
7.3	Gas isolator tap.....	95	10.2.1	Water tank.....	138
7.4	External gas connection (optional).....	96	10.2.2	Filling the water system.....	138
7.5	Changing gas bottles.....	97	10.2.3	Topping up the water.....	141
			10.2.4	Reducing the water quantity for mobile operation.....	141
8	Electrical system.....	99	10.2.5	Emptying the water system.....	141
8.1	General safety instructions.....	99	10.3	Water filter.....	142
8.2	Terms.....	99	10.4	Waste water tank.....	143
8.3	12 V power supply.....	100	10.5	External shower.....	145
8.3.1	Sockets.....	100	10.6	Bathroom.....	145
8.3.2	Starter battery.....	101	10.7	Toilet.....	148
8.3.3	Living area battery (HYMER Smart Battery System).....	101	10.7.1	Swivel toilet.....	149
8.3.4	Energy balance of the living area battery.....	105	10.7.2	Empty sewage container.....	150
8.4	Transformer/rectifier (EBL 402).....	107	10.7.3	Automatic SOG toilet ventilation (optional).....	151
8.5	7" panel.....	110	10.7.4	Winter operation.....	152
8.5.1	System Control Unit (SCU).....	111	10.7.5	Temporary lay-up.....	152
8.5.2	HYMER Connect App.....	112	11	Care.....	153
8.5.3	Bluetooth connection.....	113	11.1	General.....	153
8.6	AC converter (Victron) with integrated charger.....	113	11.2	External care.....	153
8.7	230 V power supply.....	115	11.2.1	Washing with a high-pressure cleaner.....	153
8.7.1	230 V connection (CEE socket outlet).....	115	11.2.2	Washing the vehicle.....	154
8.7.2	Connecting the 230 V power supply.....	116	11.2.3	Windows of acrylic glass.....	154
8.8	Solar installation.....	117	11.2.4	Add-on parts made of glass-fibre reinforced plastic (GRP).....	155
8.9	Fuses.....	118	11.2.5	Underbody.....	155
8.9.1	12 V fuses.....	118	11.2.6	Engine compartment.....	156
8.9.2	Values of the 12 V fuses.....	119	11.2.7	Windscreen washer system and windscreen wipers.....	156
8.9.3	230 V fuse.....	120	11.3	Air conditioning unit.....	157
9	Appliances.....	121	11.3.1	Entrance step.....	157
9.1	General.....	121	11.4	Interior care.....	158
9.2	Heater and boiler.....	121	11.5	Kitchen installation.....	159
9.2.1	Heating properly.....	122	11.5.1	General notes on care.....	159
9.2.2	Hot-air heater and boiler with digital CP plus control unit.....	123	11.5.2	Refrigerator.....	159
9.2.3	Wall flue.....	129	11.6	Stainless steel surfaces.....	160
9.2.4	Independent vehicle heater.....	130	11.7	Cushions.....	160
			11.8	Sleeping roof.....	162
			11.9	Bamboo solid wood panels.....	164

11.10	Water system.....	165	13.5	Handling of tyres	185
11.10.1	Cleaning the water tank.....	165	13.6	Repair kit	185
11.10.2	Cleaning the water pipes	166	13.7	Changing wheels	186
11.10.3	Disinfecting the water system.....	166	13.7.1	General instructions	186
11.10.4	Cleaning the waste water tank	167	13.8	Tyre pressure	187
11.10.5	Siphons.....	167			
11.11	Care for vehicle operation in winter	168	14	Troubleshooting.....	189
11.12	Lay-up.....	169	14.1	Braking system	189
11.12.1	Temporary lay-up	169	14.2	Electrical system	189
11.12.2	General/winter lay up.....	169	14.3	AC converter.....	191
11.12.3	Activating the vehicle's hibernation mode.....	172	14.4	Gas system.....	192
11.12.4	Starting up the vehicle after a temporary lay-up or after lay-up over winter	172	14.5	Cooker	192
			14.6	Heater/boiler	193
			14.6.1	Heater/boiler with CP plus digital control unit	193
12	Customer service and maintenance.....	175	14.7	Air conditioning unit	195
12.1	Service and sales partners	175	14.8	Refrigerator.....	196
12.2	Official inspections.....	175	14.8.1	General.....	196
12.3	Inspection work.....	176	14.9	Water supply.....	197
12.4	Maintenance work	176	14.10	Body	198
12.5	Air conditioning unit	177	15	Optional equipment	199
12.6	Independent vehicle heater	177	15.1	Weight details for optional equipment	199
12.7	Cooker/refrigerator	177	16	Technical data	201
12.8	Replacing bulbs, external	177	16.1	Technical data	201
12.8.1	Front lights	178	16.2	Dimensions and permissible number of persons	201
12.8.2	Rear lights	178	17	Legal notes on weight- related information	203
12.8.3	Side lights	179	Index	207	
12.9	Lighting for living area	179			
12.10	Spare parts	180			
12.11	Vehicle identification plate	181			
12.12	Warning and information stickers	181			
12.13	Dealers	182			
12.14	Replacement keys	182			
13	Wheels and tyres	183			
13.1	General	183			
13.2	Tyre selection	184			
13.3	Tyre specifications.....	184			
13.4	Deep tread tyres – LT 245/75 R16 120/116 S	185			

Observe the following instructions before first journey of the vehicle:



- ▶ Re-tighten the wheel nuts/wheel bolts after 50 km (30 miles).
- ▶ Read the instruction manual to avoid personal and material damage.

Observe the following instructions before each journey of the vehicle:



- ▶ **Check the tyre pressures.**
See Tyre pressure section.
- ▶ **Load the vehicle correctly. Observe the technically permissible maximum laden mass.**
See Payload section.
- ▶ **Fully charge batteries before each journey.**
See Starter battery and Living area battery sections.
- ▶ **In case of external temperatures below 0 °C first heat vehicle, then fill water system.**
See Water supply/Filling the water tank section.
- ▶ **Gas bottles are only to be transported within the designated gas bottle compartment.**
- ▶ **Keep forced ventilations clear.**
See Skylights and Ventilation sections.
- ▶ **Before filling the vehicle with fuel switch off the gas/diesel-operated appliances.**

If there is any risk of frost, observe the following instructions:



- ▶ **If there is any risk of frost, always heat the vehicle.**
See Heater section.
- ▶ **If the vehicle is not being used when there is risk of frost, empty the entire water system. Make sure that the 12 V power supply on the panel is switched off. Otherwise, the water pump will over-heat and may get damaged. Leave the water taps on in central position. Leave all drain cocks open. This will avoid frost damage to appliances and to the vehicle.**
See Emptying the water system section.

Please read this instruction manual completely before using the vehicle for the first time!

Always keep this instruction manual in the vehicle. Also inform all other users of the safety regulations.



▶ The non-observance of this symbol can lead to personal injury.



▷ The non-observance of this symbol can lead to damage being caused to, or inside the vehicle.



▷ This symbol indicates recommendations or special aspects.



▷ This symbol indicates actions which lead to environmental awareness.

This instruction manual contains sections which describe model-specific equipment or optional equipment. These sections are not specially marked. It may be that your vehicle has not been fitted with this optional equipment. In some cases, the actual equipment of your vehicle may therefore be different from that shown in some illustrations and descriptions.

However, your vehicle may be fitted with other optional equipment not described in this instruction manual.

Optional equipment is described when an explanation is required.

Adhere to the instruction manuals which are separately enclosed.



▷ The details "right", "left", "front" and "rear" always refer to the vehicle in direction of travel.

▷ All dimensions and weight details are "approximate".

Should the vehicle be subjected to damage due to a failure to follow the instructions in this instruction manual, then the warranty claim is deemed invalid.

Our vehicles are subjected to continuous development. Please understand that we reserve the right to alter the form, equipment and technology. Therefore, no claims can be made against the manufacturer as a result of the contents of this instruction manual. The equipment which was known and included at the time of going to press is described.

The reprinting, translation and copying, including extracts is not permitted without prior written authorisation from the manufacturer.

1.1 General

The vehicle is constructed in accordance with the latest technology and the recognised safety regulations. Nevertheless, personal injury may result and the vehicle may be damaged if the safety instructions in this instruction manual are not followed.

Before using the vehicle for the first time, equip it with the legally prescribed equipment (e.g. first aid kit, warning vest, hazard warning triangle etc.). Observe the relevant equipment regulations when travelling abroad.

Only use the vehicle in a technically impeccable condition. Follow the instructions in the instruction manual.

Malfunctions which impair the safety of persons or the vehicle should be immediately remedied by qualified personnel. To avoid further damages, observe the duty to avert, minimise or mitigate loss for the user during faults.

Have the vehicle's braking and gas systems inspected and repaired by an authorised specialist workshop only.

Alterations to the body are only to be carried out with the authorisation of the manufacturer.

The vehicle is designed for the exclusive transport of persons. Luggage and accessories may only be transported up to the maximum permissible gross weight.

Observe the test and inspection periods stipulated by the manufacturer.

1.2 Environmental tips



- ▷ Be considerate of the environment.
- ▷ Remember that: All kinds of waste water and household waste are not to be disposed of in drains or in the open countryside.
- ▷ On board, collect waste water only in the waste water tank or – if necessary – in other containers designed for that purpose.
- ▷ Only empty the waste water tank and sewage container at disposal stations, camping sites or caravan sites provided especially for this purpose. When stopping in towns and communities, observe the instructions at caravan sites or ask where there are disposal stations.
- ▷ Empty waste water tank as often as possible, even when it is not completely full (hygiene).
If possible, flush out waste water tank and, if necessary, drainage pipe with fresh water every time it is emptied.
- ▷ Never allow the sewage container to become too full. Empty the sewage container frequently, at the latest as soon as the filling level indicator lights up.
- ▷ Separate household waste according to glass, tin cans, plastic and wet waste also when on a journey. Enquire at the town or community authority about disposal points. Household waste is not to be disposed of in waste paper baskets which are situated at car parks.
- ▷ Empty waste bins as often as possible into the containers provided for this purpose. This helps to avoid unpleasant smells and an accumulation of rubbish on board.



- ▷ When parked, do not allow the engine to run more than necessary. When running idle, a cold engine releases more contaminants than usual. The running temperature of the engine is achieved more quickly whilst the vehicle is in motion.
- ▷ Use an environmentally-friendly WC chemical agent for the WC which can also be biologically degraded and only use small doses.
- ▷ When staying in towns and communities for long periods, search for parking areas which are specially reserved for motorhomes. Enquire at the town or community authority about parking spaces.
- ▷ Always leave the parking places in a clean condition.

Chapter overview

This chapter contains important safety instructions. The safety instructions are for the protection of persons and property.

2.1 Fire prevention

2.1.1 Avoidance of fire risks



- ▶ Never leave children in the vehicle unattended.
- ▶ Keep flammable materials clear of heating and cooking appliances.
- ▶ Never use portable heating or cooking appliances.
- ▶ Only authorised qualified personnel may make changes to the electrical system, gas system or appliances.

2.1.2 Fire-fighting



- ▶ Please inform yourself about the country- and location-specific requirements for firefighting in the place where you are staying and keep the required tools on hand.

2.1.3 In case of fire



- ▶ Evacuate all passengers.
- ▶ Cut off the electrical power supply and disconnect from the mains.
- ▶ Close the regulator tap on the gas bottle.
- ▶ Sound the alarm and call the fire brigade.
- ▶ Fight the fire if this is possible without risk.



- ▷ Acquaint yourself with the position and operation of the emergency exits.
- ▷ Keep escape routes clear.
- ▷ Observe the fire extinguisher instructions for use.

2.2 General



- ▶ The oxygen in the vehicle interior is used up by breathing and the use of gas operated appliances. Therefore, the used air must be replaced permanently. For this purpose, forced ventilation options (e.g. skylights with forced ventilation, mushroom-shaped vents or floor vents) are fitted to the vehicle. Never cover or block forced ventilations from the inside or outside with objects such as e.g. a winter mat. Keep forced ventilations clear of snow and leaves. There is a danger of suffocation due to increased CO₂ levels.
- ▶ Observe the headroom of the doors.



- ▷ As far as the fitted appliances (heater, cooker, refrigerator, etc.) and the base vehicle (engine, brakes, etc.) are concerned, the instruction manuals are authoritative. It is imperative that they be observed.
- ▷ Fitting accessories or optional equipment can alter the dimensions, weight and road behaviour of the vehicle. Some of the add-on parts must be entered in the vehicle documents.
- ▷ Only use wheel rims and tyres which are approved for the vehicle. Information concerning the size of the approved wheel rims and tyres is included in the vehicle documents or can be obtained from authorised dealers and service centres.
- ▷ Firmly apply the handbrake when parking the vehicle.
- ▷ If the technically permissible maximum laden mass of the vehicle exceeds 4 tonnes, a wheel chock must be used when parking on gradients. The wheel chock is provided as standard for vehicles with a technically permissible maximum mass exceeding 4 tonnes.



- ▷ When leaving the vehicle, it is imperative that all doors, external flaps and windows are closed.
- ▷ Always carry the legally prescribed equipment (e.g. first aid kit, warning vest, hazard warning triangle etc.) with you. The regulations of the host country apply when travelling abroad.
- ▷ The vehicle may only be driven by drivers who hold a driving licence which is valid for the respective vehicle class.
- ▷ When selling the vehicle, hand over all instruction manuals for the vehicle and the fitted appliances.

2.3 Road safety



- ▶ Before commencing the journey, carry out a functional check of indicating and lighting equipment, the steering and the brakes.
- ▶ If the vehicle has been stationary for a long period (approx. 10 months) have the braking and gas systems checked by an authorised specialist workshop.
- ▶ Before commencing the journey and after short interruptions of the journey, ensure that the entrance step is completely retracted.
- ▶ Before commencing the journey, open and secure the shades on the windscreen and on the driver's and front passenger's windows.
- ▶ Before commencing the journey, safely store all moving parts and all loose objects (e.g. sink cover, pendant lights, projector, screen).
- ▶ Before commencing the journey, put the table in parking position.
- ▶ Before commencing the journey, rotate all swivel seats in the direction of travel and lock in position. During the journey, the swivel seats must remain locked in place in the direction of travel.
- ▶ Before commencing the journey, close the sleeping roof.
- ▶ It is forbidden to stay in the sleeping roof during the journey.
- ▶ Before commencing the journey, push in the shower partition and close the bathroom door.
- ▶ Before commencing the journey, close the rear flap completely.



- ▶ During the journey, persons are only to sit on the permitted seats (see chapter 4). The authorised number of seats is stipulated in the vehicle documents.
- ▶ Seat belts must be worn by all passengers.
- ▶ When travelling, secure children under 13 years of age that are smaller than 150 cm, with a suitable and officially approved child restraint system.
- ▶ Only attach the child restraint system to seats that are specified for this purpose.
- ▶ **Never** use rearward-facing child restraints on a seat with **activated front airbag**. This may lead to **death** or to **serious injuries** in children.
- ▶ The base vehicle is a commercial vehicle (small truck). Adjust your driving technique accordingly.
- ▶ In the case of subways, tunnels or similar, observe the overall height of the vehicle (including roof loads).
- ▶ In winter, the roof must be free of snow and ice before commencing the journey.
- ▶ Check tyre pressure before a journey or every 2 weeks. Wrong tyre pressure causes excessive wear and can lead to damage or even to tyre burst. You can lose control of the vehicle (see section 13.8).
- ▶ Do not operate the heater at petrol stations. Danger of explosion!
- ▶ Do not operate the heater in closed spaces. Danger of suffocation!



- ▷ Before commencing the journey, distribute the payload evenly within the vehicle (see chapter 3).
- ▷ When loading the vehicle and during breaks in the journey, e.g. when re-loading luggage or food, observe the technically permissible maximum laden mass and the technically permissible maximum laden mass on the axle (see the vehicle documents).
- ▷ Before commencing the journey, close and, if necessary, secure all drawers and flaps. Engage the refrigerator door securing device.
- ▷ Before commencing the journey, close windows and skylights.
- ▷ Before commencing the journey, close all external flaps and lock them.
- ▷ Before commencing the journey, remove the external supports and retract the corner steadies or steady legs, which are fitted to the vehicle.
- ▷ During the initial journey and each time after changing a wheel, retighten the wheel bolts/wheel nuts after 50 km (30 miles). Subsequently inspect them at regular intervals in order to ensure that they are firmly seated.
- ▷ Tyres should not be older than 6 years as the material becomes brittle over time (see chapter 13).
- ▷ When using snow chains, the tyres, wheel suspension and steering are subjected to an additional load. When using snow chains, drive slowly (maximum speed 50 km/h) and only on streets which are completely covered with snow. Otherwise the vehicle could be damaged.

2.4 Towing



- ▶ Care is to be taken when connecting and detaching a trailer. Risk of accident and injury!
- ▶ No persons are to be between the motorhome and the trailer during positioning for connecting and detaching.

2.5 Gas system

2.5.1 General instructions



- ▶ The operator of the gas system is responsible for the performance of recurring inspections and for complying with the maintenance intervals.
- ▶ Before commencing the journey, when leaving the vehicle or when the gas devices are not in use, close all gas isolator taps and the main regulator tap on the gas bottle.
- ▶ When refuelling, on ferries or in the garage, all gas/diesel-operated devices must be switched off. Danger of explosion!
- ▶ Do not use gas-operated devices in closed spaces (e.g. garages). Danger of poisoning and suffocation!
- ▶ Only have the gas system maintained, repaired or altered by an authorised specialist workshop.
- ▶ Have the gas system checked by an authorised specialist workshop according to the national regulations before commissioning. This also applies for not registered vehicles. For modifications to the gas system have the gas system immediately checked by an authorised specialist workshop.
- ▶ The gas pressure regulator, the gas tubes, and the exhaust gas pipes must also be inspected. The gas pressure regulator and the gas tubes must be replaced observing the nationally defined deadlines (the latest after 10 years). The vehicle owner is responsible for seeing that this is carried out.
- ▶ In case of a defect of the gas system (gas odour, high gas consumption) there is danger of explosion! Close regulator tap on the gas bottle immediately. Open doors and windows and ventilate well.
- ▶ If the gas system is defective: Do not smoke; do not ignite any open flames, and do not operate electric switches (light switches etc.). Check the tightness of gas-conducting parts and lines with leakage search spray. Do not check with an open flame.
- ▶ Only the stipulated devices may be connected to internal connections. Do not operate any device outside the vehicle if it is connected to an internal connector.
- ▶ Before using the cooker make sure that there is sufficient ventilation. Open a window or the skylight.
- ▶ Cooking is prohibited during the journey.
- ▶ Do not use gas-operated cooking and baking equipment for heating purposes.
- ▶ When the cooker is not in use: close the gas isolator tap on the cooker and the regulator tap on the gas bottle and fit the protective cap.



- ▶ Ignition safety valves must close within 1 minute after the gas flame has extinguished. A clicking sound is audible. Check function from time to time.
- ▶ The built-in gas devices are exclusively meant for use with propane or butane gas or a mixture of both. The gas pressure regulator as well as all built-in gas devices are designed for a gas pressure of 30 mbar.
- ▶ Propane gas is capable of gasification up to -42 °C, whereas butane gas gasifies at 0 °C. Below these temperatures no gas pressure is available. Butane gas is unsuitable for use in winter.
- ▶ Due to its function and construction, the gas bottle compartment is a space which is open to the exterior. Never cover or block up the standard forced ventilations. Otherwise gas that is emitted can not be diverted to the outside.
- ▶ The gas bottle compartment must not be used as storage space.
- ▶ Secure the gas bottle compartment against unauthorised access. To do this, lock the compartment.
- ▶ The regulator tap on the gas bottle must be accessible.
- ▶ Only connect gas-operated devices which have been designed for a gas pressure of 30 mbar.
- ▶ The exhaust gas pipe must be fitted tightly to the heating system and to the vent and must be sealed. The exhaust gas pipe must not show any evidence of damage.
- ▶ Exhaust fumes must be able to escape into the atmosphere unhindered and fresh air must be able to enter unhindered. For this reason, keep the exhaust pipe and intake openings clean and unobstructed (e.g. free from snow and ice). For this reason, no snow walls or aprons may lie against the vehicle.

2.5.2 Gas bottles



- ▶ Handle full or emptied gas bottles outside the vehicle only with closed regulator tap and attached protective cap.
- ▶ Gas bottles are only to be transported within the designated gas bottle compartment.
- ▶ Place the gas bottles in vertical position in the gas bottle compartment.
- ▶ Fasten the gas bottles so that they are unable to turn or tilt.
- ▶ Connect the gas tube to the gas bottle without tension.
- ▶ If the gas bottles are not connected to the gas tube, always place the protective cap on top.
- ▶ Close the regulator tap on the gas bottle before the gas pressure regulator or gas tube are removed from the gas bottle.
- ▶ Depending on the connection, unscrew the gas tube from the gas bottle and screw it on the gas bottle again by hand or using a suitable special spanner. The screw connection on the gas bottle generally has a left-hand thread. First hand-tighten, then use the gas bottle spanner from the accessories shop.



- ▶ Only use special gas pressure regulators with a safety valve designed for vehicle use. Other gas pressure regulators are not permitted and cannot meet the demanding requirements.
- ▶ Use the gas pressure regulator defroster (EisEx) if the temperature falls below 5 °C.
- ▶ Use maximum 5 kg gas bottles. (The size of the gas bottles may vary depending on the country.)
- ▶ Never block the floor ventilation openings below the gas bottles.

2.6 Electrical system



- ▶ Only allow qualified personnel to work on the electrical system.
- ▶ Prior to carrying out work on the electrical system, switch off all devices and lights, disconnect the battery and disconnect the vehicle from the mains.
- ▶ Only use original fuses with the stipulated values.
- ▶ Only replace defective fuses when the cause of the defect is known and has been remedied.
- ▶ Never bridge or repair fuses.

2.7 Water system



- ▶ Water left standing in the water tank or in the water pipes becomes undrinkable after a short period. Therefore, before each use of the vehicle, thoroughly clean the water pipes and the water tank. After each use of the vehicle completely empty the water tank and the water pipes.
- ▶ In the case of lay-ups lasting more than a week, disinfect the water system before using the vehicle (see section 11.10.3).



- ▷ If the vehicle is not used for several days or if it is not heated when there is a risk of frost, empty the entire water system. Make sure that the 12 V power supply on the panel is switched off. Otherwise, the water pump will overheat and may get damaged. Leave the water taps on in central position. Leave all drain cocks open. Frost damage to appliances, frost damage to the vehicle and deposits in water-carrying components can be avoided in this way.

Chapter overview

This chapter contains important information which has to be noted before commencing your journey or carrying out any tasks before the journey.

At the end of the chapter there is a checklist which once again summarises the most important points.

3.1 Initial start-up



- ▷ During the initial journey and each time after changing a wheel, re-tighten the wheel bolts/wheel nuts after 50 km (30 miles). Subsequently inspect them at regular intervals in order to ensure that they are firmly seated.

The motorhome is supplied with a set of keys, consisting of keys for the base vehicle and keys for the body.

Always deposit a replacement key outside the vehicle. Make a note of the key number. Our authorised dealers and workshops can offer assistance in case of loss.

Further information in chapter 12.

When starting up for the first time or after a lay-up, the electrical system must be started up as follows:

- Switch on the fuses or (if the fuses have been pulled out) insert the fuses.
- Switch on the battery cut-off switch.
- Switch 12 V power supply on.



- ▷ The 12 V power supply must only be switched on in vehicles **without** SCU (System Control Unit). On vehicles **with** SCU, the 12 V power supply is activated automatically.
- ▷ The vehicle is not ready for operation until the above measures have been carried out.

3.2 Vehicle load capacity



- ▶ Overloading the vehicle and the axles may result, for example, in a diminished steering response (altered driving behavior), an overloading of the tires, and, as a result, an increased risk of tire blowouts or an extended braking distance. This may cause you to lose control of the vehicle, endangering yourself and other road users.
If you are not sure whether the loaded vehicle complies with the technically permissible maximum laden mass, you can weigh/check the vehicle on public scales or have it weighed by certain dealers.
- ▶ The vehicle documents state the technically permissible maximum laden mass or the mass including optional equipment ex works (actual vehicle mass), but not the weight of the laden vehicle (see section 3.2.1). For your own safety, we recommend that you have your loaded vehicle (with all passengers, luggage and personal objects) weighed on a public weighbridge before you set out on your journey.



- ▶ Uneven loading or overloading has a negative effect on driving behavior. A rear-heavy load in particular results in a reduction of the load on the front axle due to leverage effects and thus, for example, to a loss of traction, a diminished steering response (altered driving behavior), an overloading of the tires and, as a result, an increased risk of tire blowouts. This may cause you to lose control of the vehicle, endangering yourself and other road users. An evenly distributed load over the entire vehicle leads to optimum driving behavior during travel. If you are not sure whether the loaded vehicle complies with the technically permissible maximum laden mass and the technically permissible maximum laden mass on the axle, you can weigh/check the vehicle on public scales or have it weighed by certain dealers.
- ▶ Adapt the speed to the payload. The stopping distance is increased if the payload is high.



- ▷ Do not exceed the technically permissible maximum laden mass and the technically permissible maximum laden mass on the axle as stated in the vehicle documents by the payload.
- ▷ Built-in accessories and optional equipment reduce the vehicle load capacity.
- ▷ On loading, make sure that the payload's centre of gravity is as low as possible (directly above the floor of the vehicle). Otherwise this may affect the driving characteristics of the vehicle.



- ▷ If you drive the vehicle even though it exceeds the technically permissible maximum laden mass specified by the manufacturer, you may face legal consequences, such as a fine or loss of insurance.

3.2.1 Terms



- ▷ Technically speaking, the term "mass" has now replaced the term "weight". However, "weight" is still the term more frequent in common use. For better understanding, "mass" is therefore only used in the following sections for fixed formulations.

Technically permissible maximum laden mass

The technically permissible maximum laden mass is a value specified by the manufacturer that, for safety reasons, the vehicle must never exceed, even when loaded (e.g. 3500 kg). Information on the technically permissible maximum laden mass of the model you have chosen can be found in the registration papers and on the body manufacturer's nameplate in the vehicle.

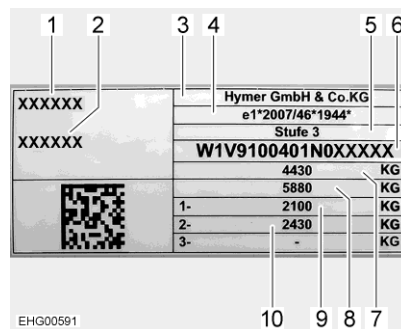

Fig. 1 Nameplate

- 1 Vehicletype
- 2 Consecutive serial number
- 3 Manufacturer
- 4 Vehicle type approval
- 5 Body stage
- 6 Chassis number
- 7 Technically permissible maximum laden mass
- 8 Permissible total towing mass (with caravan coupling option)
- 9 Technically permissible maximum laden mass on axle 1
- 10 Technically permissible maximum laden mass on axle 2

The technically permissible maximum laden mass consists of the **actual vehicle mass** and the **payload**.

In the vehicle documents, the manufacturer has specified the technically permissible maximum laden mass.

Actual vehicle mass

The actual vehicle mass consists of the mass in running order and the weight of the optional equipment fitted at the factory.

Mass in running order

The mass in running order is the weight of the ready-to-drive series vehicle (excluding optional equipment fitted at the factory).

The mass in running order is made up as follows:

- Unladen weight (mass of the empty vehicle) with factory-installed standard equipment (excluding optional equipment fitted at the factory)
- Driver's weight
- Basic equipment weight
- Greases, oils and cooling liquids filled in
- Fresh water tank filled up to 100 %
- Aluminium gas bottle filled up to 100 %
- Fuel tank filled to 90 %

75 kg are calculated for the weight of the driver, regardless of how much the driver really weighs.

Basic equipment includes all equipment and fluids required for safe and proper vehicle use. The weight of the basic equipment includes:

- A full fresh water system
- A full heating system
- The power cables for the 230 V power supply
- A full toilet flushing system
- The installation kit for an auxiliary battery if an auxiliary battery can be used

The waste water tank and the sewage container are empty.

Example for calculating the basic equipment

Water tank with 20 l (during the journey)	20 kg
Gas bottle (5 kg _{gas} + 6.6 kg _{bottle})	+ 11.6 kg
230 V power cable	+ 4 kg
Total	= 35.6 kg

The mass in running order and the actual vehicle mass are specified by the manufacturer in the vehicle documents.

Remaining load capacity

To determine the remaining load capacity, it is important that you know the actual weighed mass of your vehicle. Upon completion of your vehicle, therefore, we determine the actual weight of your vehicle for the first time by weighing it at the end of the line. This includes the mass in running order plus the weight of all ordered and factory-fitted optional equipment.

You can use this actual weighed mass to calculate the remaining load capacity for baggage or other accessories.

Example:

Technically permissible maximum laden mass	-	actual weighed mass	-	mass of the passengers	=	remaining load capacity
3500 kg	-	3000 kg	-	225 kg (3 x 75 kg)	=	275 kg



- ▷ Please note that the factory calculation of the remaining load capacity for the mass of the driver (included in the actual weighed mass) and the mass of the passengers is based on a generalized mass of 75 kg per seat. Due to deviating body weights, however, the actual remaining load capacity of your vehicle may vary.
- ▷ The actual factory-weighed mass of your vehicle may vary slightly afterwards due to weather conditions and, for example, the associated absorption or release of moisture. Any further subsequent modification of your vehicle, e.g. through the additional installation of accessories by the dealer or other attachments and/or conversions, will additionally influence the actual weighed mass of the vehicle communicated and consequently also the remaining load capacity. It is the responsibility of the dealer after picking up the vehicle at the factory until delivery, and subsequently your responsibility from the time of handover by the dealer, to ensure that the technically permissible maximum laden mass is not exceeded. If you are not sure whether the loaded vehicle complies with the technically permissible maximum laden mass, you can weigh/check the vehicle on public scales or have it weighed by certain dealers.
- ▷ We will inform your dealer of the actual weighed mass of your vehicle and the remaining load capacity when we issue the invoice. Your dealer is required to pass on the information to you. If you have not received this information, you can contact your dealer and request it. Our scales meet all legal and standard requirements and are regularly maintained, tested and, calibrated. Nevertheless, a slight tolerance is technically unavoidable. Moreover, the weight of the vehicle may vary slightly due to weather conditions and, for example, the associated absorption or release of moisture. The actual weight of the vehicle may therefore deviate from the actual weight communicated by a few kilograms.

The payload is made up as follows:

- Conventional load
- Additional equipment
- Personal equipment



- ▷ The vehicle load capacity can be increased by reducing the actual weight. To do this, it is allowed for example to empty the fluid containers or to remove the gas bottles.

You will find explanations on the individual components of the payload in the following text.

Conventional load The conventional load is the weight specified by the manufacturer for the passengers.
 Conventional load means: 75 kg are calculated for every seat specified by the manufacturer, regardless of how much the passengers actually weigh. The driver's seat is already included in the mass in running order and must **not** be counted.
 In the vehicle documents, the manufacturer specifies the number of seats.

Optional equipment Optional equipment includes all equipment not included in the standard equipment which is fitted to the vehicle under the responsibility of the manufacturer.

- Caravan coupling (optional)
- Bike or motorcycle rack (optional)
- Solar installation (optional)

Information about the weights of the various optional equipment devices can be obtained from the manufacturer.

Personal equipment Personal equipment includes all items carried in the vehicle that are not included in the conventional load and optional equipment. For example, personal equipment can include the following:

- Foodstuffs
- Crockery
- Small appliances
- Clothes
- Bedding
- Toys
- Books
- Toiletries

No matter where kept, personal equipment also includes:

- Animals
- Bikes
- Boats
- Surfboards
- Sports equipment

For the personal equipment, according to the applicable regulations, the manufacturer must use a minimum weight that is determined according to the following formula:

Formula Minimum weight M (kg) = 10 x N + 10 x L

Explanation N = maximum number of people including the driver, as stated by the manufacturer
 L = total length of the vehicle in metres

3.2.2 Calculating the vehicle load capacity



- ▶ Never exceed the technically permissible maximum laden mass!
- ▶ The technically permissible maximum laden mass and the weight including optional equipment fitted at the factory (actual mass) is shown in the vehicle documents, but not the weight of the laden vehicle (see section 3.2.1). For your own safety, we recommend that you have your loaded vehicle (with all passengers, luggage and personal objects) weighed on a public weighbridge before you set out on your journey.

The vehicle load capacity (see section 3.2.1) is the difference in weight between

- the technically permissible maximum laden mass in a laden condition and
- the actual vehicle mass.

Example for calculating the vehicle load capacity

	Mass in kg to be calculated	Calculation
Technically permissible maximum laden mass according to vehicle documents	3500	
Actual vehicle mass including standard equipment according to the vehicle documents	- 3070	
This results in a permissible load capacity of	430	
Flat-rate value of 10 kg per meter vehicle length (in the example: 7.00 m)	- 70	
Conventional load e.g.: 3 persons each weighing 75 kg	- 225	
Optional equipment and accessories	- 40	
For the personal pay-mass this results in	= 95	

The pay-mass is calculated based on the regulation (EC) no. 1230/2012.

The calculation of the vehicle load capacity from the difference between the technically permissible maximum laden mass and the actual vehicle mass specified by the manufacturer is however only a theoretical value.

Only if the vehicle is weighed on a public scale with filled tanks (fuel and water), filled gas bottles and complete optional equipment (and accessories) can the actual vehicle load capacity be determined.

To do this, proceed as follows:

- First only drive the vehicle on to the weighbridge with the front wheels and have it weighed.
- Then drive the vehicle on to the weighbridge with the back wheels and have it weighed.

The individual values give the current masses on the axles. These are important for the correct loading of the vehicle (see section 3.2.3). The sum of these values is the current weight of the vehicle.

The actual load capacity is the difference between the technically permissible maximum laden mass and the weighed vehicle weight.

This can be used to determine the weight that remains for the personal equipment:

- Determine the weight of the passengers and subtract it from the value for the actual vehicle load capacity.

The result is the weight that is permitted for the actual load of the personal equipment.

3.2.3 Load securing and load distribution



- ▶ For safety reasons, never exceed the technically permissible maximum laden mass.
- ▶ Distribute the load evenly on the left and right sides of the vehicle.
- ▶ Distribute the load evenly on both axles. Observe the technically permissible maximum laden mass on the axle specified in the vehicle documents. Observe the permissible load-carrying capacity of the tyres (see chapter 13).
- ▶ Heavy loads behind the rear axle can reduce the load on the front axle due to the leverage effect ($\frac{l_1}{l_2}$). This applies especially to long rear extensions, if a motorbike is transported on the rear carrier or if there is a heavy load in the rear storage space. The release of the front axle negatively affects the driving quality, especially for front-driven vehicles.
- ▶ Store all objects in such a way that they cannot slip.
- ▶ Store heavy objects (awning, tin cans, etc.) close to the axles. Low-lying storage spaces whose doors do not open in the direction of travel are particularly suited for storing heavy objects.
- ▶ Stack light objects (laundry) in the roof storage cabinet.
- ▶ Distribute items (loads) evenly in the compartments and cupboards.



- ▷ Only load the drawers with a maximum of 15 kg.
- ▷ The maximum permitted load for the roof storage cabinet above the kitchenette is 15 kg.



- ▷ Please observe the maximum permissible load of the rear garage or rear storage compartment at all times. The specified maximum permissible load of the rear garage or rear storage compartment may be influenced by the selection of further optional equipment, such as trailer couplings or frame extensions. However, the technically permissible maximum laden mass and the technically permissible maximum laden mass on the axle must not be exceeded under any circumstances. Especially when stowing or attaching heavy accessories or heavily laden accessories at the rear, the mass on the axle must be checked and complied with. For this reason, please note that the maximum load may not be fully utilized if this would result in the exceedance of the technically permissible maximum laden mass or technically permissible maximum laden mass on the axle.
- ▷ Further information on correct loading can be found in the sections "Technically permissible maximum laden mass" (page 20) and "Technically permissible maximum laden mass on the axle (mass on the axle)" (page 27).

Large storage compartments also offer room for heavy objects. The mass on the front or rear axle may be exceeded as a result.

However, the individual axles may not be overloaded under any circumstances. That is why it is important, at which distance to the axles the load is stored.

When loading the vehicle, please observe the following instructions to ensure safe driving:

- Baggage and other items carried in the vehicle must be evenly distributed between the left and right sides of the vehicle.
- Heavy or bulky items should be stowed as close to the ground as possible in stowage boxes provided for this purpose and near the axles, and they must be secured against slipping.
- Light and other items can be stowed in lockers and storage compartments.
- Always ensure that the doors and flaps on the cabinets and storage compartments are properly secured.
- Use only suitable clamping systems to secure items against slipping. Please recheck all tie-downs before commencing travel.



- ▶ Uneven loading has a negative effect on driving behavior. A rear-heavy load in particular results in a reduction of the load on the front axle due to leverage effects and thus, for example, to a loss of traction, a diminished steering response (altered driving behavior), an overloading of the tires and, as a result, an increased risk of tire blow-outs. This may cause you to lose control of the vehicle, endangering yourself and other road users. An evenly distributed load over the entire vehicle leads to optimum driving behavior during travel.



- ▷ The technically permissible maximum laden mass and the technically permissible maximum laden mass on the axle must not be exceeded. Especially when stowing or attaching heavy accessories or heavily laden accessories at the rear, the mass on the axle must be checked and complied with. If you are not sure whether the loaded vehicle complies with the technically permissible maximum laden mass and the technically permissible maximum laden mass on the axle, you can weigh/check the vehicle on public scales or have it weighed by certain dealers.
- ▷ For individual models, a maximum load is specified by the body manufacturer for cabinets, drawers, storage compartments, or other storage spaces. This maximum load can be seen on the stickers attached on site and must be observed at all times. However, the technically permissible maximum laden mass and the technically permissible maximum laden mass on the axle must not be exceeded under any circumstances. For this reason, please note that the stated maximum load may not be fully utilized if this would result in the exceedance of the technically permissible maximum laden mass or technically permissible maximum laden mass on the axle.
- ▷ Further information on correct loading can be found in the sections "Technically permissible maximum laden mass" (page 20) and "Technically permissible maximum laden mass on the axle (mass on the axle)" (page 27).

To distribute the load correctly, you will need a scale, a tape measure, a calculator and some time.

Two simple formulas are needed to calculate the effect of the weight of the load on the axles:

Formulas

$A \times G : R =$ weight on the rear axle

Weight on the rear axle – $G =$ weight on the front axle

Explanation

A = distance between storage space and front axle in cm

G = weight of the load in the storage space in kg

R = wheelbase of the vehicle (distance between axles) in cm



- ▷ Measure the external distances horizontally from the centre of the front wheel to the centre of the storage space or to the centre of the back wheel.

Technically permissible maximum laden mass on the axle (mass on the axle)

The technically permissible maximum laden mass on the axle or group of axles (hereafter referred to as mass on the axle) refers to the vehicle- and axle-specific load that may be transferred from the wheels of an axle or group of axles to the road surface. The mass on the axle is a value specified by the manufacturer that, for safety reasons, the vehicle must never exceed, even when loaded. You will find information on the mass on the axle of your vehicle in the registration papers and on the body manufacturer's nameplate in the vehicle.

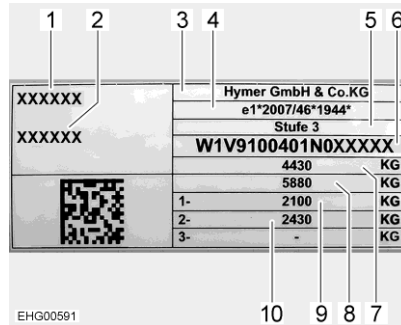

- 1 Vehicle type
- 2 Consecutive serial number
- 3 Manufacturer
- 4 Vehicle type approval
- 5 Body stage
- 6 Chassis number
- 7 Technically permissible maximum laden mass
- 8 Permissible total towing mass (with caravan coupling option)
- 9 Technically permissible maximum laden mass on axle 1
- 10 Technically permissible maximum laden mass on axle 2

Fig. 2 Nameplate



- ▶ If the technically permissible maximum laden mass on the axle is exceeded, the vehicle may be damaged (e.g. due to a broken axle or tire blowout) and driving performance may be considerably impaired. This may cause you to lose control of the vehicle, endangering yourself and other road users. We therefore recommend weighing the final loaded vehicle including all passengers, before commencing travel in order to ensure compliance with the mass on the axle and the technically permissible maximum laden mass at all times. For this purpose, you can weigh/check the vehicle on public scales or have it weighed by certain dealers.



- ▷ Please note that the mass on the respective axles or axle groups may differ. For this reason, please read the information provided in the registration papers carefully.
- ▷ If you drive the vehicle even though it exceeds the technically permissible maximum laden mass on the axle specified by the manufacturer, you may face legal consequences, such as a fine or loss of insurance.
- ▷ It is possible that the chassis manufacturer of your vehicle specifies a minimum load for the front axle in order to achieve optimum driving behavior. Therefore, please also always observe the information regarding this from the operating instructions of the chassis manufacturer.
- ▷ For further information on correct loading, please refer to section "Load securing and load distribution" (page 25).

Calculating masses on the axles:

- Multiply the distance between storage space and front axle (A) with the weight of the load in the storage space (G) and divide the result by the wheelbase (R). The result is the weight of the load in the storage space on the rear axle. Make a note of this weight and of the storage space.
- In a second step, subtract the weight in the storage space (G) from the weight calculated beforehand. If the result is a **positive** value (example 1), this means that the load on the front axle is **reduced** by this value. If the result is a **negative** value (example 2), this means that the load on the front axle is **increased**. Make a note of this value, too.
- Calculate all storage spaces of the vehicle in the same way.
- In a last step, add all weights calculated for the rear axle to the mass on the rear axle and add (or subtract) all weights calculated for the front axle to (or from) the mass on the front axle.
How to determine the mass on the rear axle and the mass on the front axle is described in section 3.2.2.

If the calculated value exceeds the permissible maximum laden mass on the axle, the load must be distributed in a different way.

If the load on the front axle is too low, the grip of the tyres on the road is reduced (traction). This applies in particular to vehicles with front-wheel drive. In this case, the load must be redistributed, too.

Example calculation

		Example 1	Example 2
Distance to the front axle	A	(A1) 450 (cm)	(A2) 250 (cm)
Weight in the storage space	G	x 100 (kg)	x 50 (kg)
Wheelbase of the vehicle	R	÷ 325 (cm)	÷ 325 (cm)
Load on the rear axle (add to the axle load)		138.5 (kg)	38.5 (kg)
Weight in the storage space		- 100 (kg)	- 50 (kg)
Load relief to the front axle (subtract from the axle load)		38.5 (kg)	
Load on the front axle (add to the axle load)			-11.5 (kg)

Increase and reduction of load capacity

In the case of an increase of load capacity, a change in the chassis usually increases the technically permissible maximum laden mass of the vehicle, the technically permissible maximum laden mass on the axle and, as a result, the remaining load capacity for luggage, camping equipment, etc.

In contrast to an increase of load capacity, a reduction of load capacity reduces the technically permissible maximum laden mass of the vehicle, the technically permissible maximum laden mass on the axle and, as a result, the remaining load capacity for luggage, camping equipment, etc. As a rule, a technical modification of the chassis is not performed.



- ▷ Due to the change in the technically permissible maximum laden mass, increases or reductions of load capacity may affect the permitted seats, the chassis, and the mass on the axle. If you have any questions, feel free to contact the responsible technical testing center for advice.
- ▷ A reduction or increase of load capacity may result in changes to the legal requirements resulting from the new technically permissible maximum laden mass of the vehicle. This applies in particular to the legal requirements from the German Road Traffic Act (StVO), the German Road Vehicle Registration Regulation (StVZO), and tax and insurance regulations. An increase of technically permissible maximum laden mass to over 3500 kg may, for example, affect the driving license class or result in different speed limits or prohibitions on passing and overtaking. Toll payment requirements may also change due to the new technically permissible maximum laden mass. Therefore, inform yourself about the current legal situation with regard to the new technically permissible maximum laden mass of the vehicle and seek advice on this from the appropriate bodies. Please note that national regulations in the country of your destination and countries visited in transit may differ from those in your home country.
- ▷ For more information on the actual weighed mass of your vehicle and the remaining load capacity, please refer to section "Remaining load capacity" (page 21).

3.3 Towing



- ▶ Care is to be taken when connecting and detaching a trailer. Risk of accident and injury!
- ▶ No persons are to be between the motorhome and the trailer during positioning for connecting and detaching.
- ▶ Observe the permissible nose weight and rear axle load of the motorhome. The nose weight and rear axle load must not be exceeded. The values of the nose weight and rear axle load are included in the documents of the vehicle and the caravan coupling.



- ▷ Trailer with an overrun brake: Do not connect or detach trailer with the overrun brake on.
- ▷ Caravan coupling with detachable ball neck: If the ball neck is mounted incorrectly, there is the danger of the trailer breaking away. Observe the operating manual for the caravan coupling.
- ▷ When opening the rear portal, ensure that you do not damage the rear portal.



- ▷ The maximum permissible nose weight of the vehicle is 80 kg.

3.4 Caravan coupling (optional)



- ▶ When attaching a caravan coupling, refer to the vehicle documents for the maximum nose weight and the technically permissible maximum towable mass.
- ▶ Retighten the caravan coupling fixing screws after 1000 operating hours.



- ▷ Have your authorised dealer or authorised service centre install the add-on parts. They will also take care of all the formalities for you.
- ▷ Observe the manufacturer's instruction manual.



Fig. 3 Caravan coupling (detachable)

3.5 Entrance step



- ▶ Before commencing the journey and after short interruptions of the journey, ensure that the entrance step is completely retracted.
- ▶ Do not stand in the direct range of the entrance step while it is being retracted or extended.
- ▶ Do not step on the entrance step until it has extended completely. There is a risk of injury!
- ▶ To prevent danger of slipping, clean the entrance step if necessary before entering (snow, ice, mud, etc.).
- ▶ Do not under any circumstances raise or lower persons or loads with the entrance step.
- ▶ Observe the maximum load for the entrance step according to the manufacturer's instruction manual.



- ▷ Do not grease or lubricate the pivot bearing and joints of the entrance step (see chapter 11).

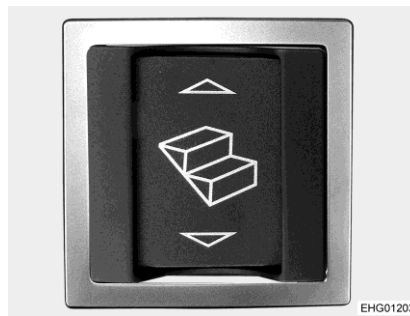

Fig. 4 Rocker button for entrance step (entrance area)



Fig. 5 Rocker button for entrance step (dashboard)



- ▷ The rocker button in the entrance area has a covering frame to protect it from being actuated unintentionally.

Retracting: ■ Press the rocker button (Fig. 4) in the entrance area or the rocker button (Fig. 5) on the dashboard in the driver's cabin.

Extending: ■ Press the rocker button (Fig. 4) situated in the entrance area.

When the engine is running and the entrance step is extended, a warning tone is heard. The warning tone stops as soon as the entrance step is retracted.

3.6 Projector



- ▶ Before commencing the journey, store the projector and screen in a safe place.

3.7 Kitchen area



▶ In the event of an accident or heavy braking, flying objects could injure the occupants of the vehicle. Before moving off, secure all moveable objects and remove all loose objects and store them securely.

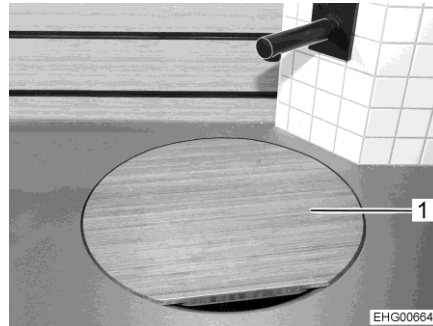

1 Sink cover

Fig. 6 Sink cover

- Remove the sink cover (Fig. 6,1) and store it securely in the cabinet.

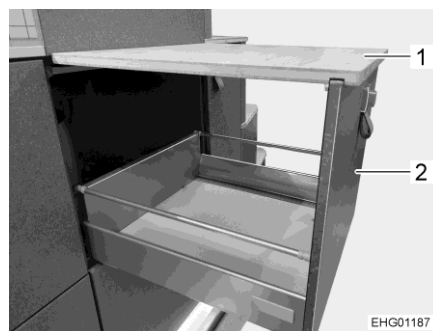

1 Work top expansion
2 Drawer

Fig. 7 Work top expansion

- Remove the work top expansion (Fig. 7,1) from the drawer (Fig. 7,2) and store it safely.

3.8 Snow chains



▶ If the vehicle is equipped with 18" tyres, do not use snow chains



- ▷ Only mount snow chains if there is a clearance of at least 50 mm between the tyres and the vehicle body.
- ▷ When using snow chains, the tyres, wheel suspension and steering are subjected to an additional load. When using snow chains, drive slowly (maximum speed 50 km/h) and only on streets which are completely covered with snow. Otherwise the vehicle could be damaged.
- ▷ Observe the fitting instructions issued by the manufacturer of the snow chains.

The use of snow chains is subject to the legal regulations of the individual countries.

- Always mount snow chains to the rear wheels.
- After a few metres, check the tension of the snow chains.

3.9 Road safety



- ▶ Check tyre pressure before a journey or every 2 weeks. Wrong tyre pressure causes excessive wear and can lead to damage or even to tyre burst. You can lose control of the vehicle (see section 13.8).
- ▶ Add-on parts can be exposed to adverse conditions (storms, ice, vibrations, etc.) and require close monitoring despite careful design and manufacturing. Therefore, check the tight fit of the add-on parts at certain intervals and before long journeys.

Work through the checklist before and when commencing the journey:

Service partners

No.	Checks	Checked
1	Service and sales partners noted (see section 12.1)	

Base vehicle

2	All vehicle documents are on board	
3	Tyres in proper condition and tyre pressure correct	
4	Vehicle lighting, brake lights and reversing lights function	
5	Oil levels for engine, gearbox and power steering controlled	
6	Coolant and fluid for windscreen washers filled up	
7	Brakes function	
8	Brakes react evenly	
9	When braking, the vehicle remains in the lane	

Housing body, outside

10	Awning fully retracted	
11	Roof free of snow and ice (in winter)	
12	Sleeping roof closed	
13	Rear flap closed	
14	External connections and lines disconnected and stored away	
15	External supports removed	
16	Fitted steady legs retracted and fixed in place	
17	Wheel chocks removed and stored away	
18	Entrance step retracted (observe warning tone)	
19	External flaps closed and locked	
20	Living area door locked	
21	Overall height of the vehicle including roof rack when loaded measured and noted. Keep the height information close at hand in the driver's cabin	

	No.	Checks	Checked
Housing body, inside	22	Windows and skylights closed and locked	
	23	Projector and screen safely stowed away	
	24	Shower partition pushed in and bathroom door closed	
	25	Loose parts such as pendant lights stored or fixed	
	26	Open storage spaces empty	
	27	Loose sink cover (if present) stored securely	
	28	Work top expansion securely stored	
	29	Optional additional make-up mirror removed and securely stored	
	30	Refrigerator door secured	
	31	Loose objects and suspension elements of the multifunctional wall removed and safely stored	
	32	All drawers and flaps closed	
	33	Living area doors and sliding doors secured	
	34	Children's seats only mounted on the seats approved for this purpose	
	35	Swivel seat locking device for driver's seat and front passenger's seat locked	
	36	Shades in the driver's cabin opened and secured	
	37	Secretary closed	

Gas system	38	Gas bottle firmly fixed in the gas bottle compartment so that it is unable to turn	
	39	If the gas bottle is not connected to the gas tube, always fit the protective cap	
	40	Regulator tap on the gas bottle and gas isolator taps are closed	

Electrical system	41	Check the battery voltage / battery capacity (in %) of the starter and living area battery (see chapter 8). If the panel indicates that the battery voltage / battery capacity is too low, the respective battery will need to be recharged. Observe the notes and instructions in chapter 8	
--------------------------	----	--	--

Chapter overview

This chapter contains instructions on how to drive the motorhome.

4.1 Driving



- ▶ The base vehicle is a commercial vehicle (small truck). Adjust your driving technique accordingly.
- ▶ When you start the engine, warning signals such as "entrance step extended" can sound. Under certain conditions (a cold start in winter) after the engine is started it can take up to 15 seconds for these warning signals to sound.
- ▶ A seat belt is fitted for each seat which is permitted for travel. Please keep your seat belt fastened during the journey.
- ▶ Never open your seat belts when travelling.
- ▶ Passengers must remain in the seats provided.
- ▶ The doors must remain locked.
- ▶ Avoid braking with a jerk.
- ▶ If a navigation system is used, only change the destination when the vehicle is stationary. Drive to a car park or stop in a safe area when changing the destination.



- ▷ Drive slowly on poor roads.
- ▷ Take extreme care when driving onto ferries, crossing uneven roads and driving in reverse. Because of the relatively large overhang, larger vehicles might swing out and "touch ground" in unfavourable conditions. This can cause damage to the underbody or to parts fitted there, e.g. a motorcycle rack.



- ▷ If an accident occurs as a result of these instructions not being observed, the manufacturer will not be responsible for damages caused.
- ▷ The safety measures stipulated in chapter 2 have to be observed.

4.2 Breakdown assistance in the event of vehicle-related technical problems



- ▶ In case of emergency call the national emergency number or use the Mercedes-Benz emergency call system (SOS button, refer to base vehicle instruction manual).

For breakdown assistance and any questions on the base vehicle, the Mercedes-Benz customer centre is at your disposal. The call to the Mercedes-Benz customer centre is set up via the "me connect" communication module in the vehicle.

Position The button for the call for breakdown assistance is installed in the roof operating unit.



- ▷ Only use the button for the call for breakdown assistance in the event of technical problems with the base vehicle. Any questions on the superstructure of the vehicle cannot be answered.

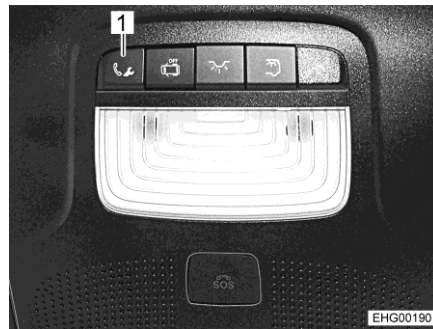

Fig. 8 Button for the call for breakdown assistance

- Calling:**
- Press the button (Fig. 8,1) for the call for breakdown assistance. A call to the Mercedes-Benz customer centre is initiated.

On the multifunction display appears a message indicating that the call is being initiated. The audio output is muted. The vehicle data are transmitted; this might take a few seconds. After that, a staff member of the Mercedes-Benz customer centre will contact you.



- ▷ In some countries, a voice message prompts you to confirm the transmission of the vehicle data. After confirming, the vehicle data are transmitted.

- Disconnecting the call:**
- Press phone button on the multifunction steering wheel.

4.3 Driving speed



- ▶ The vehicle provides a large contact surface for wind. A sudden cross-wind can be especially dangerous.
- ▶ Uneven or one-sided loading affects road performance.
- ▶ Driving on unknown streets, you may encounter hazardous road conditions and unexpected driving situations. Therefore, in the interest of safety, make sure your driving speed is appropriate to any given driving situation and environment.

4.4 Brakes



- ▶ Have defects on the braking system immediately remedied by an authorised specialist workshop.

Before each journey

Before each journey, check by means of a braking test:

- Do the brakes function?
- Do the brakes react evenly?
- Does the vehicle remain in the lane when braking?

4.5 Additional main beam

An additional pair of headlights or an additional headlight bar for an additional LED main beam will have been installed on the driver's cabin roof.



- ▶ The additional LED main beam strongly dazzles oncoming traffic. Dip the headlights in case of oncoming traffic. Take into account that the additional main beam has a longer range than the principal main beam.
- ▶ Do not use the Mercedes light assistant to dip the lights. Even when the function "AUTO" has been set, dip the lights manually (switch off the principal main beam and the additional LED main beam on the steering column lever).



- ▷ The engine must be running to be able to activate the additional LED main beam.
- ▷ The function "Headlight flashing" is not supported by the additional LED main beam.

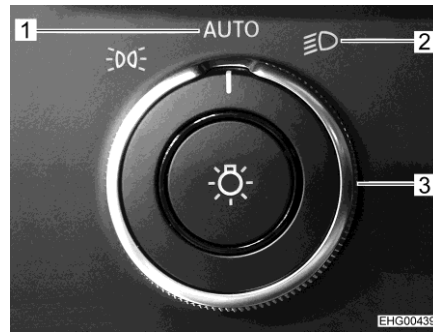

- 1 AUTO position
- 2 Driving light position
- 3 Rotary light switch Mercedes

Fig. 9 Rotary light switch

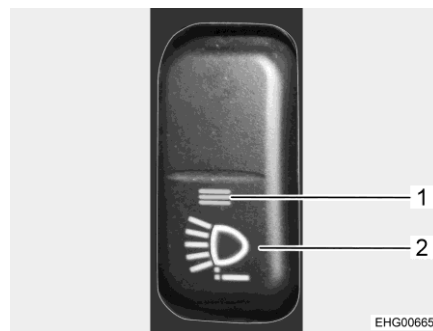

- 1 Function indicator
- 2 Rocker button

Fig. 10 Rocker button

Using the additional LED main beam:

- Turn the Mercedes rotary light switch (Fig. 9,3) to the position "AUTO" (Fig. 9,1) or to the position Driving light (Fig. 9,2).
- Press the rocker button (Fig. 10,2). The function indicator (Fig. 10,1) is lit red. The text message "Additional lighting active" appears briefly in the display of the combined instrument.
- Switch the principal main beam on or off at the steering column lever of the vehicle (see instruction manual of the vehicle).

To deactivate the additional LED main beam, either switch off the engine or press the rocker button (Fig. 10,2) again. The red function indicator (Fig. 10,1) goes out.

4.6 Seating arrangement



- ▶ During the journey, persons are only to sit on the permitted seats. The authorised number of seats is stipulated in the vehicle documents.
- ▶ During the journey sitting on the divans is not permitted.
- ▶ Seat belts must be worn by all passengers.

Seats which may be used during travel are equipped with a seat belt.

4.7 Seat belts

4.7.1 General

The vehicle is equipped with seat belts in the living area on the seats for which seat belts are compulsory by law. National regulations apply to fastening of seat belts.



- ▶ Fasten your seat belts before the beginning of the journey and keep them fastened during the journey.
- ▶ Do not damage or trap belts. Have damaged seat belts changed by an authorised specialist workshop.
- ▶ Do not alter the belt fixing devices, automatic seat belt winders and the seatbelt locks.
- ▶ Only use one seat belt for **one** adult person.
- ▶ Do not belt in objects together with persons.
- ▶ Seat belts are not sufficient for persons who are less than 150 cm tall. In these cases use additional restraining devices. Observe test certificate.
- ▶ Only attach the child restraint system to seats that are specified for this purpose. We strongly recommend to install child restraint systems preferably in the second row of seats.
- ▶ After an accident, replace the seat belts (have it replaced).
- ▶ During the journey, do not tilt the backrest too far backwards. Otherwise the functionality of the seat belt is no longer guaranteed.

4.7.2 Fastening the seat belts correctly



- ▶ Do not twist the belt. The belt must be positioned smoothly against the body.
- ▶ When fastening the seat belt, adopt the correct sitting position.

The seat belt is correctly fastened when the lap belt passes below your stomach and across the hip bone. The shoulder belt must pass across the chest and shoulder (not across your neck). The belt must always be taut against your body. Any bulky or padded clothing should therefore be removed before you start your journey.

4.8 Child restraint systems



- ▶ When travelling, secure children under 13 years of age that are smaller than 150 cm, with a suitable and officially approved child restraint system.
- ▶ Only attach the child restraint system to seats that are specified for this purpose.
- ▶ Fasten the children's seat belts before commencing the journey and make sure that their seat belts are kept fastened during the journey.
- ▶ Never use rearward-facing child restraint system on a seat with activated front airbag. This may lead to death or to serious injuries in children.
- ▶ Use a rear-facing child restraint system ("reboard system") only when the front and side air bags on the passenger side are switched off. The front passenger airbag cannot be deactivated on Mercedes-based vehicles. In this case, only a forward-facing child seat may be used. Observe the separate instruction manual for the base vehicle and the warning notices in the vehicle. If no rear-facing child restraint system is in use, switch the airbags back on again.

Child restraint systems are divided into five classes:

Class	Body weight	Approximate age
0	Up to 10 kg	Up to 9 months
0+	Up to 13 kg	Up to 18 months
I	9 kg to 18 kg	9 months to 4 years
II	15 kg to 25 kg	3 years to 7 ½ years
III	22 kg to 36 kg	6 years to 12 years

The following table shows, which child restraint systems can be used on which seats.

Seats	Age groups			
	< 10 kg (0-9 months)	< 13 kg (0-24 months)	9-18 kg (9-48 months)	15-36 kg (4-12 years)
Front passenger's seat, front	X	X	UF	UF

Meaning of letters:

X: Seat is not suitable for children in this age group

UF: Suitable for front facing restraint systems of "universal" category, authorised for the use in this weight category

4.9 Driver's seat and front passenger's seat



- ▶ Before commencing the journey, rotate all swivel seats in the direction of travel and lock in position.
- ▶ The seats must remain fixed in position during the journey and are not to be rotated.



- 1 Handle (shifting the seat cushion)
- 2 Lever (rotating the seat)
- 3 Lever (adjusting in longitudinal direction)
- 4 Armrest

Fig. 11 Driver's seat (right side)

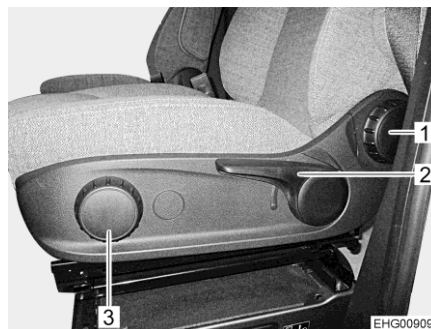

- 1 Rotary knob (adjusting the backrest)
- 2 Lever (adjusting the seat height)
- 3 Rotary knob (adjusting the seat inclination)

Fig. 12 Driver's seat (left side)

Driving position

During the journey, the driver's and front passenger's seats must be rotated in the direction of travel and locked in position.

Always turn the seats over the central aisle.

- Pull the lever (Fig. 11,2). The seat locking device is released.
- Rotate the seat inwards, into the direction of travel and lock in position.

Distance to the pedals

Adjust the driver's seat so that the driver can depress the pedals comfortably.

- Pull the lever (Fig. 11,3).
- Push the seat forwards or backwards.
- Release the lever. The seat must audibly lock into place.

Seat height

Adjust the seat height so that a comfortable sitting position and an unobstructed view of the road are possible.

- Pull the lever (Fig. 12,2) upward or push it downward until the desired seat height is reached.

- Seat inclination** Adjust the seat inclination so that the thighs rest on the seat surface without any pressure.
- Turn the rotary knob (Fig. 12,3) until the desired seat inclination is reached.
- Backrest** Adjust the angle of the backrest of the driver's seat so that the steering wheel can be held with the arms slightly bent.
- Turn the rotary knob (Fig. 12,1) until the desired backrest inclination is reached.
- Armrest** The height of the armrests can be continuously adjusted.
- Swivel the armrest (Fig. 11,4) all the way up.
 - Swivel the armrest all the way down.
 - Swivel the armrest upwards to the desired position.
- Seat cushion**
- Pull out the seat cushion by the handle (Fig. 11,1) or push it in until the desired position is reached.

4.10 Reversing camera

The vehicle is equipped with a reversing camera (Fig. 13,1). The reversing camera is installed in a camera module (Fig. 13,2) on top, at the rear of the vehicle.

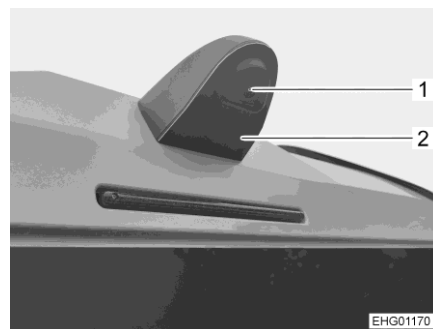

- 1 Reversing camera
- 2 Camera module

Fig. 13 Camera module

When engaging reverse, the reversing camera switches on automatically and records the close-up area behind the vehicle. The image of the reversing camera is fed into the multimedia system and shown on the display in the driver's cabin.

No camera image is displayed while travelling forward.



- ▷ If the rear flap is open in strong sunlight, the camera module may overheat. The reversing camera then switches off temporarily until it has cooled down sufficiently.

4.11 Roman shades for driver's window and front passenger's window



- ▶ During the journey, the Roman shades for the driver's window and front passenger's window must be open, in a fixed position and secured.

4.12 Refuelling



- ▶ When refuelling, all gas-operated devices must be switched off. Danger of explosion!
- ▶ When refuelling, the TRUMA diesel heater must be switched off. Danger of explosion!



- ▷ The fuel filler neck is part of the base vehicle.
- ▷ The fuel filler neck is labelled with the word "Diesel".

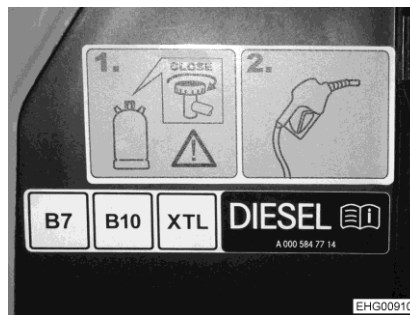

Fig. 14 Warning notice (fuel filler neck)

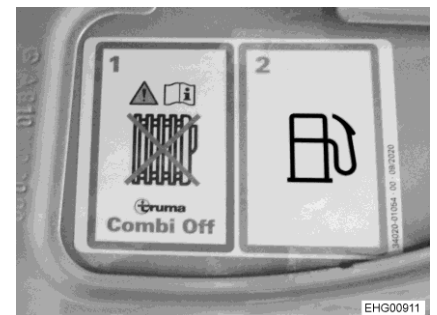

Fig. 15 Warning notice (TRUMA diesel heater)

Refer to the instruction manual for the base vehicle for the position of the fuel filler neck.

4.13 Ad-Blue®



- ▷ The filler neck for Ad-Blue® is located underneath the bonnet.
- ▷ Refer to the instruction manual of the base vehicle for any information and instructions regarding Ad-Blue®.

4.14 Towing



- ▶ To prevent any damages on the vehicle due to inadequate towing, observe the instructions in the operating manual of the base vehicle before towing.
- ▶ If the ignition key cannot be turned in the ignition lock, do not tow the vehicle. The steering will be locked.
- ▶ If, in the case of a vehicle with front-wheel drive and automatic transmission, the engine is not running: carefully push the vehicle a stretch of maximum of 15 meters. In the event of a breakdown, only transport these vehicles on a trailer or a transportation vehicle.



- ▷ If the engine is not running or the power supply is disrupted, the servo assistance for the steering and brakes will not be operational. A considerable amount of force will be required for steering and braking.

The vehicle manufacturer recommends to transport the vehicle on a transportation vehicle or a trailer. If the vehicle has to be towed, use a towing bar. The towing bar must be approved for the weight of the vehicle.



- ▷ National regulations apply to towing.

Chapter overview

This chapter contains instructions on how to pitch the vehicle at the campsite.

5.1 Entrance step

In order to exit the vehicle, first fully extend the entrance step. If the entrance step is extended while the engine is still running, a warning tone will sound.

5.2 Ramps



- ▷ Ramps are not included in the scope of delivery. Different models are available at the accessories shop.

To enable the vehicle to be parked on the level, ramps can be used for height compensation when the vehicle is parked on a hill or on uneven ground.

5.3 Wheel chock

When parking the vehicle on slopes or inclines use a wheel chock.

If the technically permissible maximum laden mass of the vehicle exceeds 4 tonnes, a wheel chock must be used when parking on gradients. The wheel chock is provided as standard for vehicles with a technically permissible maximum laden mass exceeding 4 tonnes.

5.4 Supports

5.4.1 General instructions



- ▷ Do not use the fitted supports as a vehicle jack. They supports are only for stabilising the parked vehicle to prevent the rear axle from bottoming out.
- ▷ When pitching the vehicle, ensure that the supports are evenly loaded.
- ▷ Before driving away, wind up the supports as far as they can go, fully retract and secure them.



- ▷ When the ground is soft, place a pad or block under the supports in order to prevent the vehicle from sinking into the ground.
- ▷ Pitch the vehicle so that it is as horizontal as possible. Otherwise, the water from the shower tray will not be able to drain properly.

5.4.2 Mechanical steady legs



- ▶ The steady legs must not be used to jack up the vehicle in order to work beneath it, e.g. to change a wheel or carry out maintenance work.
- ▶ Whilst the vehicle is in a jacked up position, persons must not lie down under it.



- ▷ Depending on the model, the hexagonal nut has a joint, which can be used to bring the attached socket spanner into a more convenient position for turning.

In order to ensure their correct function, clean and grease the interior tubes of the steady legs regularly.

The length of the steady legs can be adjusted according to the model.

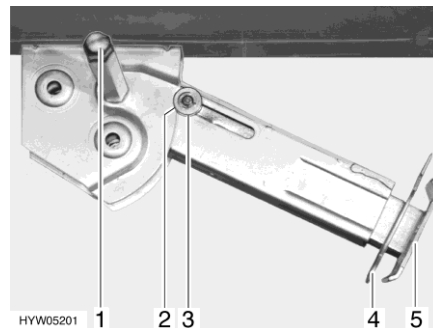

- 1 Hexagon
- 2 Notch
- 3 Guide disc
- 4 Splint
- 5 Support leg extension

Fig. 16 Steady leg

- Extending:**
- Place the socket spanner on the hexagon nut (Fig. 16,1) and rotate until the steady leg is in a perpendicular downward position.
 - Remove the splint (Fig. 16,4) out of the support foot extension (Fig. 16,5).
 - Extend the support foot extension until it has reached the required length.
 - Insert the splint in the support foot extension.
 - Rotate the hexagonal nut until the steady leg rests completely on the ground and the vehicle is in a horizontal position.
- Retracting:**
- Place the socket spanner on the hexagon nut (Fig. 16,1) and rotate until the steady leg is clear of the ground.
 - Remove the splint (Fig. 16,4) out of the support foot extension (Fig. 16,5).
 - Push in the support foot extension (Fig. 16,5) and insert the splint (Fig. 16,4) in the drilled hole in the support foot extension.
 - Rotate the hexagonal nut (Fig. 16,1) with the socket spanner until the steady leg has swung upwards and the guide disc (Fig. 16,3) has completely retracted into the notch (Fig. 16,2).



- ▷ Before commencing the journey, observe the following: Are all steady legs and support foot extensions retracted completely and secured with the splint?

5.5 230 V connection

The vehicle can be connected to an 230 V power supply.



Fig. 17 230 V connection

5.6 Refrigerator



- ▷ Continuous operation of the refrigerator without external 230 V power supply can discharge the living area battery.

Check the charging condition of the living area battery on the panel or HYMER Connect App. If possible, connect external 230 V power supply.

5.7 Awning, electrically operated (optional)



- ▷ If the living area door is open 90° and the awning is extended, the awning may collide with the living area door. Therefore, before extending the awning, open or close the living area door so far that there is no risk of collision (see Fig. 18).
- ▷ When the support legs are not positioned, extend the awning a maximum of 1 m.
- ▷ Retract the awning in strong wind, rain or snow.
- ▷ In the case of light rain, shorten one of the support legs so that water can run off.
- ▷ In case of light wind or rain, anchor the awning with ropes on both sides.
- ▷ Only retract the awning when the fabric is dry. When the awning must be retracted while the fabric is still wet: Extend the awning as soon as possible, in order to dry out the fabric.
- ▷ Before retracting, remove leaves and coarse dirt from the awning.



- 1 Awning
- 2 Living area door

Fig. 18 Living area door and awning

Extending the awning:

- Open or close the living area door (Fig. 18,2) so far that the awning (Fig. 18,1) cannot collide with the living area door when it is extended. (If the living area door is open 90°, there is a risk of collision.)

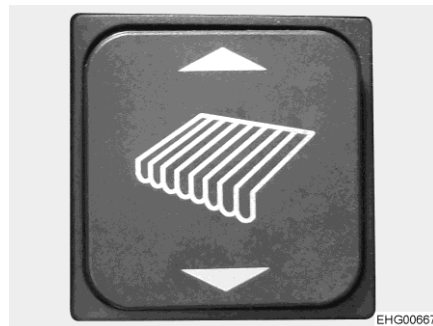

Fig. 19 Awning rocker button (entrance area)

- Press the lower triangle on the rocker button (Fig. 19) until the awning has reached the desired position.

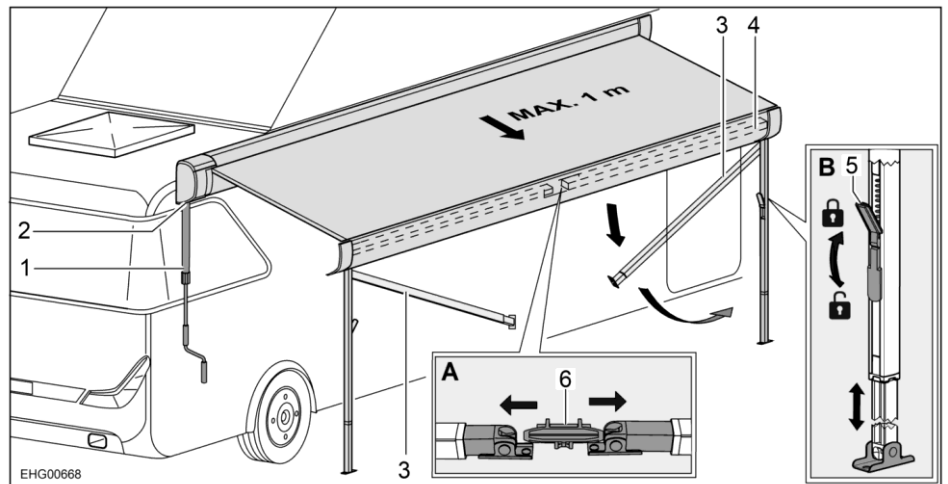

Fig. 20 Position support legs

- 1 Crank
- 2 Bayonet socket
- 3 Support leg
- 4 Front bar
- 5 Lock
- 6 Holder

- Release support legs (Fig. 20,3) from holder (Fig. 20,6) in the front bar (Fig. 20,4). In order to do this, apply slight outward pressure on the support legs (Fig. 20,A).
- Fold out the support legs.
- Release the locks (Fig. 20,5) of the support legs. In order to do this, fold the catch lever downwards.
- Pull lower part of the support legs out to the desired length (Fig. 20,B).
- Position the support legs.
- Close the locks (Fig. 20,5) of the support legs. In order to do this, fold the catch lever upwards.
- Extend the awning further if necessary. While doing so, reposition the support legs several times.
- Set the support legs to their final height.
- Fix the support legs to the floor with tent pegs.

Retracting the awning:

- Remove the pegs from the legs.
- Retract the awning to approx. 1 m. In order to do this, press the upper triangle on the rocker button (Fig. 19).
- If necessary, clean the support legs (Fig. 20,3).
- Open the locks (Fig. 20,5) on the support legs. In order to do this, fold the catch lever downwards.
- Push the lower part of the support legs in completely.
- Close the locks (Fig. 20,5) of the support legs. In order to do this, fold the catch lever upwards.
- Fold in both support legs upward into the front bar of the awning and let them click into position. In order to do this, apply slight outward pressure to the support legs.
- Retract the awning completely. In order to do this, press the upper triangle on the rocker button.

Emergency release

In case the electrical control of the awning does not work, an emergency release with a crank is provided.

- Insert the crank (Fig. 20,1) to the bayonet socket (Fig. 20,2).
- Turn the crank in a clockwise direction or in an anticlockwise direction as required until the awning has reached the desired position.
- Store the crank safely after use.

5.8 Rear wall



- ▶ Before commencing the journey, close the rear platform and rear window.
- ▶ Before commencing the journey, make sure that the rear platform has been locked.
- ▶ Use the supplied rear ladder to climb up and down. Use handle.



- ▷ Do not load the rear platform with more than a maximum of 300 kg when it has been folded out.
- ▷ Do not pull the shade out further than the stop. The stop is located about halfway up the rear opening.



- ▷ When the vehicle is parked: make sure that the rear platform and rear window are closed and that the rear platform has been locked via the vehicle's central locking system before leaving the vehicle.

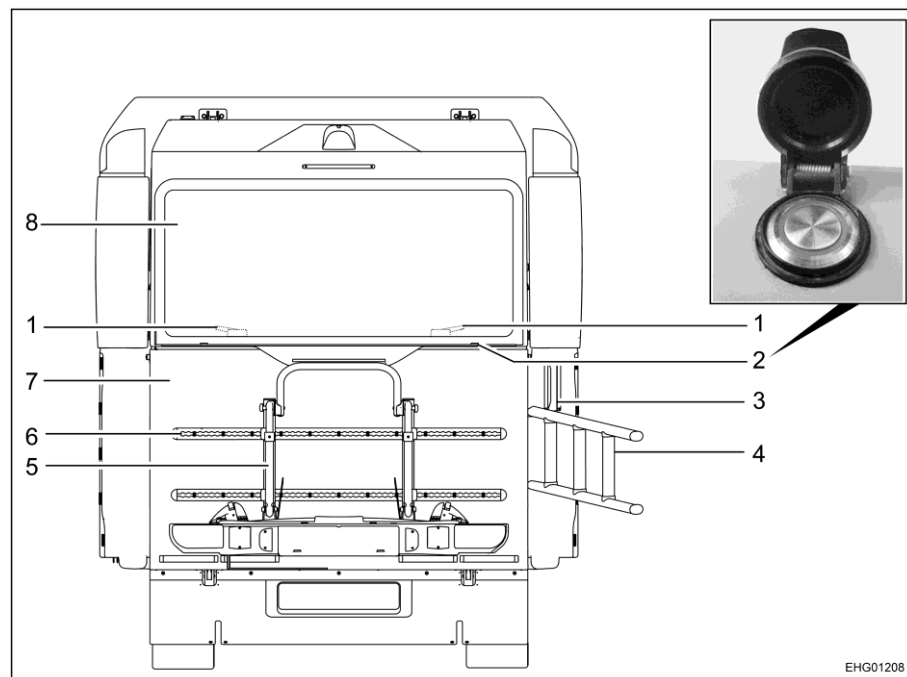

Fig. 21 Rear wall

- | | | | |
|---|----------------|---|------------------------|
| 1 | Locking handle | 5 | Bike rack |
| 2 | Push button | 6 | Fixing rail (Airlines) |
| 3 | Handle | 7 | Rear platform |
| 4 | Rear ladder | 8 | Rear window |

The rear wall consists of two elements that can be opened independently of each other: rear platform (Fig. 21,7) and rear window (Fig. 21,8).

The rear window is operated with two locking handles (Fig. 21,1), the rear platform with a push button (Fig. 21,2). The push button is located on the end edge of the rear platform and is protected with a cap against accidental pressing.

A support made of bamboo wood (in yacht design) is attached to the rear platform. Thus, the rear platform can be walked on when it is open and can be used like a terrace.

To be able to climb onto the rear platform (or off the rear platform) from the outside, the vehicle is equipped with a rear ladder (Fig. 21,4). The rear ladder is stored in a compartment integrated into the rear platform. In addition, a handle (Fig. 21,3) has been fitted in the area of the rear ladder to enable safe ascent.

When the rear platform is lowered, a safety guard (see section 5.8.2) prevents falling from the rear platform.

When the rear platform is closed, it is locked via the vehicle's central locking system.

The rear platform can be manually swivelled 90° downwards.



Risk of injury due to falling rear platform!

- ▶ Never lower the rear platform when the attachments on the rear platform are loaded.
- ▶ When lowering the rear platform, ensure that there are no persons or objects in the danger zone.



Risk of falling due to strong pull on the leather loop caused by attachments!

- ▶ If attachments are fitted to the rear platform: stand securely in the vehicle and tighten the leather loop completely. Only then unlock the rear platform.
- ▶ Slowly lower the rear platform from a safe position.



- ▷ Before lowering the rear platform, make sure that there is sufficient free space behind the vehicle. The open rear platform requires least one metre of space.
- ▷ If no attachments are fitted to the rear platform, it is sufficient to unlock the rear platform and push it slightly outwards. The rear platform then moves down automatically with mechanical brakes. All you need to do is guide it gently with the leather loop.
- ▷ Attachments fitted to the rear platform increase the weight of the rear platform. When lowering, greater force is then required to guide the rear platform with the leather loop.

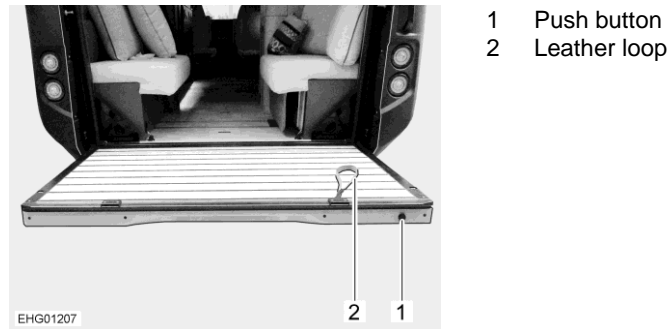

Fig. 22 Rear platform, open

Lowering the rear platform (opening):

- If attachments are fitted to the rear platform: ensure that the attachments are unladen.
- If the vehicle's central locking system is locked: activate and unlock the rear platform via the central locking system.
- Stand securely in the vehicle in front of the rear platform.
- Unlock and switch off the rear window, see section 5.8.4.
- Keep the leather loop (Fig. 22,2) taut.
- Open the cap of the push button (Fig. 22,1) and unlock the rear platform using the push button.
- If no attachments are fitted to the rear platform: push the rear platform slightly and guide it by the leather loop while the rear platform moves downwards.
- If attachments are fitted to the rear platform: note that lowering requires greater force. Hold the leather loop (Fig. 22,2) and slowly guide the rear platform downwards.
- Attach the rear ladder, see section 5.8.1.
- Attach the safety guard, see section 5.8.2.



- ▷ The damper in the rear platform not only dampens it when opening, but also when closing. This prevents damage to the rear platform if it is closed too quickly.

Closing the rear platform:

- If there are objects on the rear platform: remove the objects.
- Remove the safety guard, see section 5.8.2.
- Remove the rear ladder, see section 5.8.1.
- Stand securely behind the vehicle in front of the rear platform.
- Grasp the rear platform with both hands and swivel it upwards until it engages in the closed position.
- Check that the rear platform is securely locked. To do this, shake the rear platform.
- Lock the rear platform via the vehicle's central locking system.

5.8.1 Rear ladder



Risk of injury when descending from the rear platform and when climbing onto the rear platform!

- ▶ Only descend from the rear platform or climb onto the rear platform using the rear ladder supplied.
- ▶ Use handle.

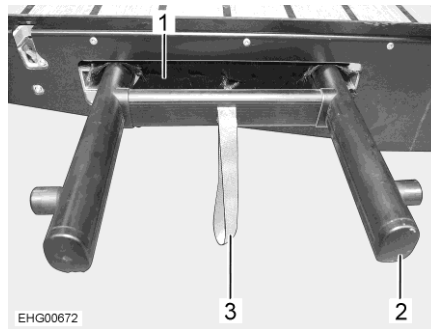

- 1 Storage compartment
- 2 Rear ladder
- 3 Loop

Fig. 23 Rear ladder (in the storage compartment)

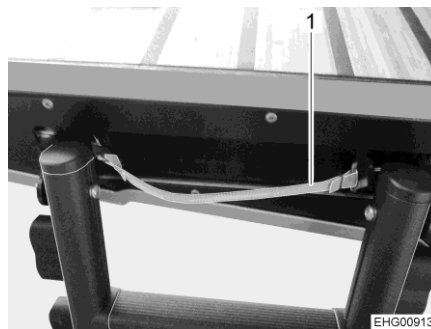

- 1 Release strap

Fig. 24 Rear ladder (set up)

Pulling out the rear ladder:

- Pull the rear ladder (Fig. 23,2) out of the storage compartment (Fig. 23,1) by the loop (Fig. 23,3).
- Fold down the rear ladder and place it securely on the ground.



- ▷ The rear ladder is connected to the rear platform via hinges and does not need to be attached separately.

Pushing in the rear ladder:

- If necessary: clean the rear ladder.
- Fold up the rear ladder.
- Pull the release strap (Fig. 24,1) and push the rear ladder into the storage compartment. When doing this, make sure that the loop remains accessible.

5.8.2 Rear platform safety guard

The safety guard for the rear platform is stored in the shelf above the driver's cabin.

- Remove the storage bag from the shelf and unpack all the parts of the safety guard on the rear platform.
- Assemble the two corner rods such that each corner rod has a hook at one end and a pin at the other end.

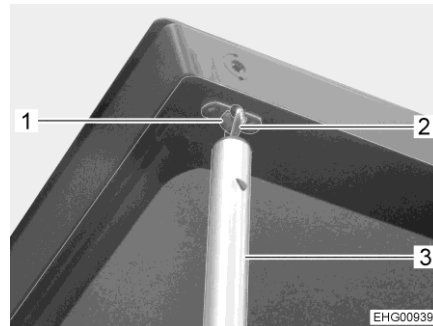

Fig. 25 Attaching the corner rod to the rear window

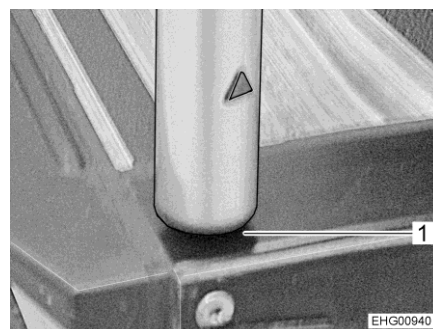

Fig. 26 Inserting the corner rod into the rear platform

- On both sides of the rear platform, attach the hook (Fig. 25,2) of the assembled corner rods (Fig. 25,3) to the matching eyelet (Fig. 25,1) on the rear window.
- Insert the pin at the lower end of each corner rod into the opening (Fig. 26,1) provided in the rear platform.



Fig. 27 Introducing the crossbar into the tarpaulin



Fig. 28 Putting together the crossbar

- Slide the two halves of the crossbar into the guides of the tarpaulin from the outside (Fig. 27).
- Put the two halves of the crossbar together (Fig. 28).

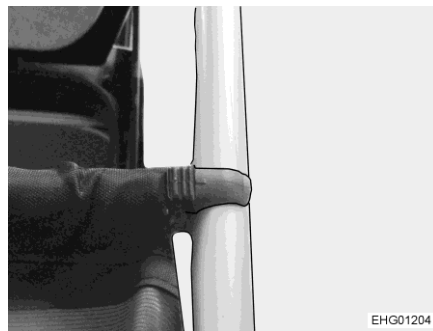

Fig. 29 Attaching the crossbar to the corner rods

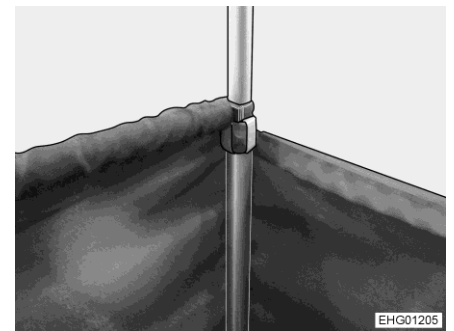
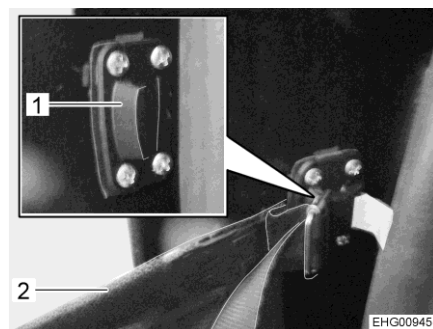

Fig. 30 Positioning the tarpaulin around the corner rods

- Have the two ends of the crossbar snap onto the corner rods (Fig. 29). Observe the marking on the tarpaulin when doing this.
- Guide the tarpaulin around the outside of the corner rods on both sides (Fig. 30).



- 1 Fixing point
- 2 Strap

Fig. 31 Fixing the tarpaulin

- Attach the straps (Fig. 31,2) on all four corners of the tarpaulin to the fixing points (Fig. 31,1) provided.

5.8.3 Camping chairs

The vehicle is equipped with two camping chairs that can be fixed in the rear area (one camping chair per vehicle side).



Fig. 32 Camping chairs (fixed in the vehicle)

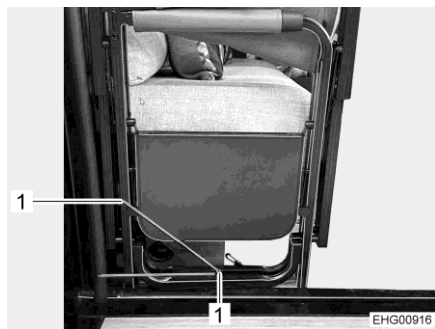

1 Fixing eye

Fig. 33 Fixing eyes for camping chairs

- Slide the camping chairs (Fig. 32) onto the bracing plate in the rear.
- Fix the camping chairs to the body of the bench using the eyelets (Fig. 33,1).



Fig. 34 Protective cover

- Pull the protective cover (Fig. 34) over the camping chairs.

5.8.4 Rear window

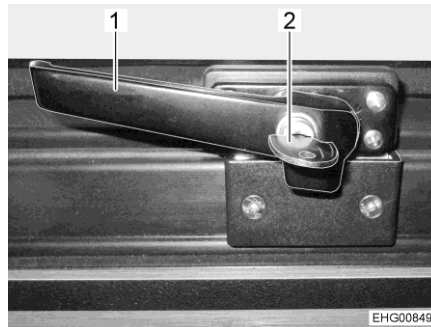

- 1 Locking handle
- 2 Key

Fig. 35 Locking handle (closed)

Opening the rear window:

- Turn the key (Fig. 35,2) half a turn outwards.
- Turn both locking handles (Fig. 35,1) a quarter turn so that the locking handles point to the centre of the window (Fig. 36).
- Open the rear window to the desired position.



▷ The rear window remains in any desired position.

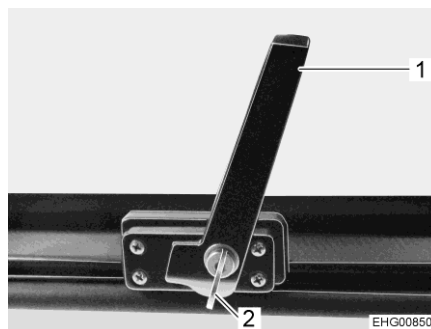

- 1 Locking handle
- 2 Key

Fig. 36 Locking handle (open)

Closing the rear window:

- If the rear platform is open: close the rear platform.
- Close the rear window.
- Turn both locking handles (Fig. 36,1) a quarter turn so that the locking handles point outward (Fig. 35).
- Lock the locking handles. In order to do this, turn the key (Fig. 36,2) half a turn inwards.

5.8.5 Insect screen / Darkening screen

An insect screen and a darkening screen are built into the frame at the rear of the vehicle. This allows the interior of the vehicle to be protected from insects and/or darkened when the rear platform and rear windows are open. The insect screen completely covers the opening in the rear, the darkening screen covers the upper half of the opening.

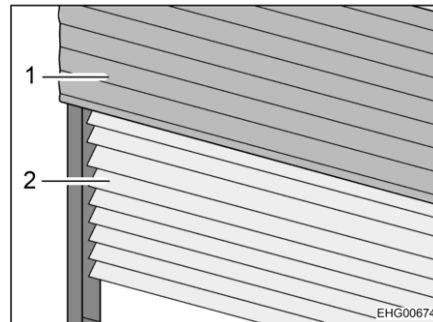

1 Darkening screen
2 Insect screen

Fig. 37 Darkening screen and insect screen (schematic)

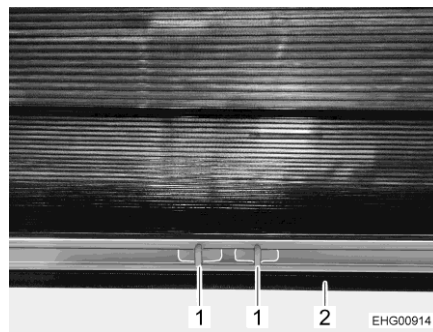

1 Tongue
2 Bar

Fig. 38 Insect screen

Pulling out the insect screen:

- Press the two tongues (Fig. 38,1) on the insect screen together and pull the insect screen (Fig. 37,2) down by the bar (Fig. 38,2) as far as it will go.

Pushing in the insect screen:

- Grasp the insect screen by the holding bar and push it in completely.

Pulling out the darkening screen:

- Grab the darkening screen (Fig. 37,1) by the holding bar and pull it out as far as it will go.



- ▷ Do not pull the shade out further than the stop. The stop is located about halfway up the rear opening.

Pushing in the darkening screen:

- Grasp the darkening screen by the holding bar and push it in completely.

5.9 Sleeping roof



- ▶ Before commencing the journey, close the sleeping roof completely.
- ▶ Ensure that the cover of the sleeping roof is not damaged.
- ▶ Attach safety support before staying in the sleeping roof. In the event of damage to the cover, the safety support prevents the sleeping roof from closing unexpectedly and injuring people who are in the sleeping area.
- ▶ Keep the forced ventilation open.
- ▶ Secure the access stairs to the sleeping roof with a safety net.
- ▶ Do not step out onto the vehicle roof from the sleeping area. The roof area in front of the sleeping roof cannot be used as a staying area. Do not damage the permanently integrated insect screen.
- ▶ Before closing the sleeping roof, make sure that there are no persons or objects in the sleeping roof.
- ▶ Do not stay in the sleeping roof during a thunderstorm.



- ▷ To avoid condensation, always ventilate the sleeping roof well and keep it dry. Especially in winter operation and on cold summer nights, ensure that there is no build-up of moisture.
- ▷ If condensation has formed in the sleeping roof: dry the sleeping roof thoroughly before closing it.



- ▷ Solar panels are fitted on the sleeping roof as standard.



Fig. 39 Sleeping roof, open

The sleeping roof consists of a rigid canopy and an inflatable cover. The cover is inflated via an electronically controlled pneumatic system. The operation takes place on the 7" panel of the vehicle.

Fully opening the sleeping roof involves attaching a safety support to the rear of the sleeping roof.

The sleeping area in the sleeping roof is equipped with integrated mattresses whose degree of firmness can be individually adjusted. In order to do this, the beds in the elevating roof have two separate air chambers. Depending on the setting, the air chambers are filled to different degrees (via the vehicle's pneumatic system).

The filling of the air chambers is controlled via the central display in the vehicle or via the HYMER Connect App.

To let light and air into the sleeping roof, a window is integrated at the rear of the sleeping roof. The window is closed with a firmly attached insect screen. Passage to the vehicle roof is not possible. The window can be darkened with a roll-up textile element.

The sleeping roof is winterproof. If necessary, the sleeping roof can be heated via the heating of the living area or cooled via the air conditioning unit.

The sleeping area in the sleeping roof is equipped with reading lamps and ambient lighting.

Access to the sleeping roof is via a fixed access stairs with bamboo steps.

Opening/closing the sleeping roof:

- Before closing the sleeping roof, make sure that the textile element in front of the window is closed.
- Before closing the sleeping roof, unplug all devices connected to the combination socket, remove them and stow them away safely.
- Before closing the sleeping roof, make sure that the safety supports have been removed.
- Select the "Open" function or the "Close" function on the 7" panel. The sleeping roof is opened or closed automatically.
- If the sleeping roof cannot be operated via the 7" panel: Operate the sleeping roof via the emergency controls (Fig. 41). The emergency controls are installed in the bottom cupboard of the secretary.



- ▷ If the sleeping roof cannot be operated using the emergency controls, contact the customer service.



Fig. 40 Safety supports

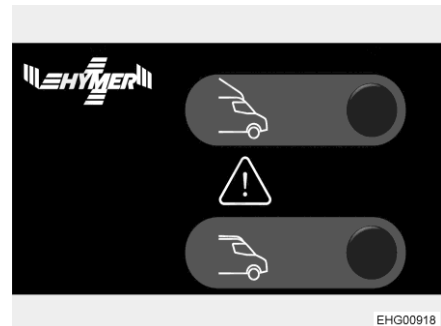

Fig. 41 Emergency controls

Installing the safety supports:

- Insert the safety supports (Fig. 40) on the rear side of the sleeping roof into the holders provided and pull them upwards as far as they will go.

Removing the safety supports:

- Retract and remove the safety supports.
- Store the safety supports securely.

Safety net The access stairs must be secured against falling down with a safety net. The upper end of the safety net is attached to the access opening. The lower end of the safety net must be manually attached to one of the steps.

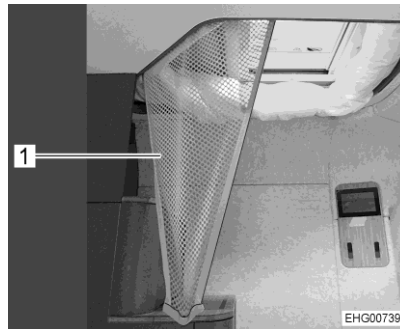

Fig. 42 Safety net on access stairs

1 Safety net

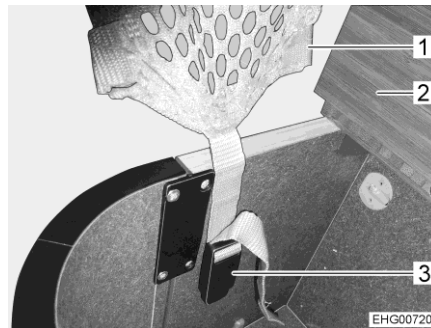

Fig. 43 Fastening safety net

1 Safety net
2 Cover
3 Belt lock

Installing the safety net:

- Unroll the safety net (Fig. 42,1).
- Open the cover (Fig. 43,2) of the step.
- Attach the belt at the lower end of the safety net (Fig. 43,1) to the belt lock (Fig. 43,3).

5.9.1 Shade

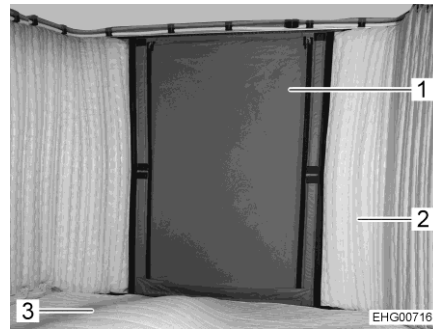

- 1 Textile element
- 2 Sleeping roof cover
- 3 Mattress

Fig. 44 Window in the sleeping roof (shade closed)

Opening the shade:

- Open the zips on the textile element (Fig. 44,1).
- Roll up the textile element to the desired position and lock it.

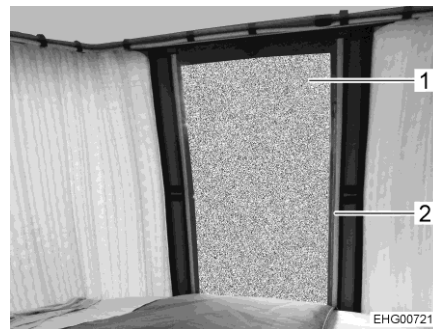

- 1 Window
- 2 Insect screen

Fig. 45 Window in the sleeping roof (shade open)

Closing the shade:

- Unroll the textile element completely.
- Close the zips on the textile element.



- ▷ As an additional child safety lock, the zip can be secured with a padlock. A matching padlock with 2 keys is included.

5.9.2 Temperature regulation in the sleeping roof

In the sleeping roof, air outlets are fitted in a circumferential rail, through which either warm or cold air can flow into the sleeping area. For this purpose, sliding regulators have been built into one of the steps of the access stairs. These sliding regulators are labelled.

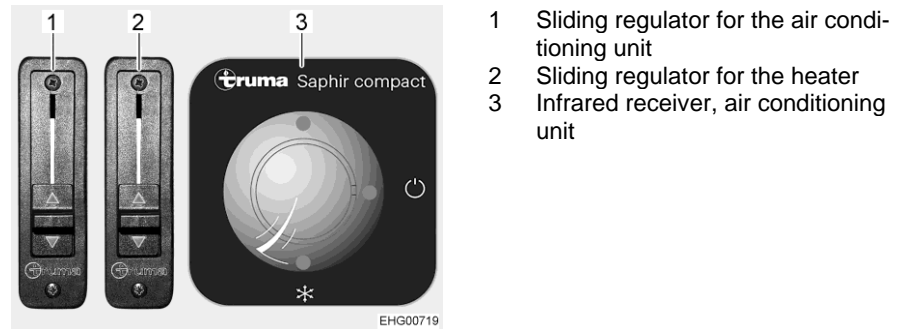

Fig. 46 Sliding regulator

Heating the sleeping roof:

- If the sliding regulator for the air conditioning unit (Fig. 46,1) is open: close the sliding regulator for the air conditioning unit.
- Open the sliding regulator for the heater (Fig. 46,2).

Cooling the sleeping roof:

- If the sliding regulator for the heater is open: close the sliding regulator for the heater.
- Open the sliding regulator for the air conditioning unit.

5.9.3 Shelf board

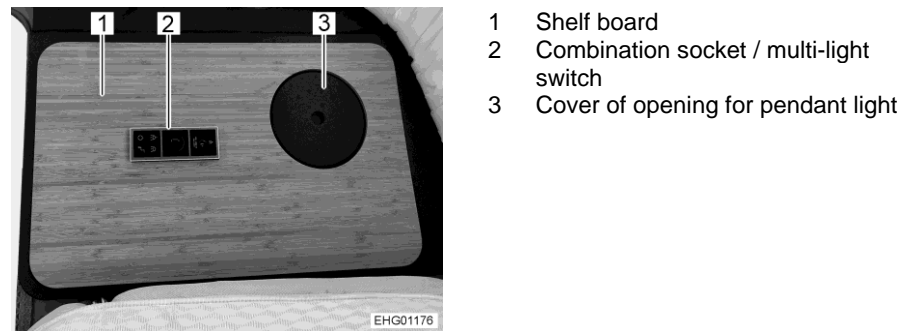
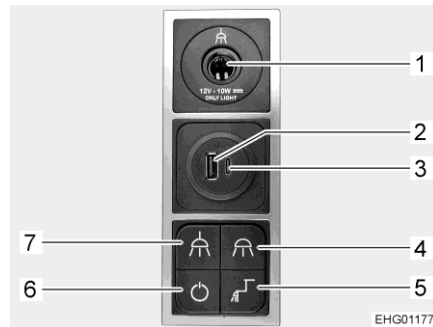

Fig. 47 Shelf board

A shelf board (Fig. 47,1) with combination socket / multi-light switch (Fig. 47,2) and a removable cover (Fig. 47,3) is installed at the head end of the sleeping roof.

The removable cover closes the opening for the pendant light.

Combination socket / multi-light switch



- 1 12 V socket
- 2 USB A port
- 3 USB C port
- 4 Light switch for recessed spotlight
- 5 Light switch for staircase lighting
- 6 Main light switch (sleeping roof)
- 7 Light switch for pendant light

Fig. 48 Combination socket / multi-light switch

USB socket The USB socket contains a connection for a USB A plug (Fig. 48,2) and a connection for a USB C plug (Fig. 48,3). The USB sockets can be used to charge the batteries of devices with a charging current of up to 3.6 A.

12 V socket Only a mobile reading lamp / pendant light from Hymer may be connected to the 12 V socket (Fig. 48,1). Devices from other manufacturers may be damaged.

Multi-light switch The light switch for the recessed spotlight (Fig. 48,4), for the staircase lighting (Fig. 48,5), for the pendant light (Fig. 48,7), and the main light switch for the sleeping roof (Fig. 48,6) are integrated into the multi light switch.

Pendant light The pendant light can be attached to the shelf board so that it shines either upwards or downwards.

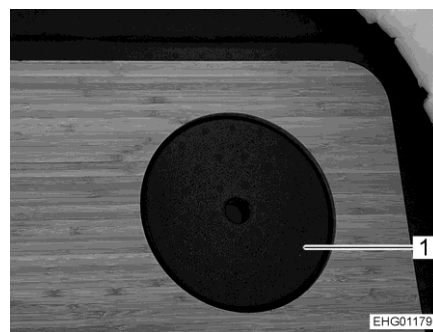

- 1 Cover

Fig. 49 Cover of opening for pendant light

Inserting the pendant light: ■ Lift the cover (Fig. 49,1).

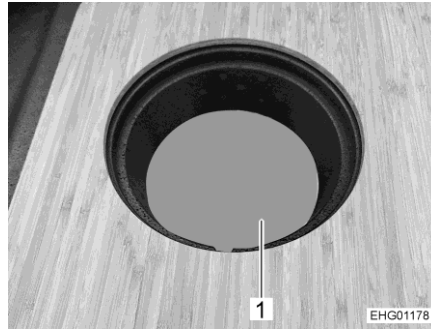

1 Opening for pendant light

Fig. 50 Opening for pendant light

- Insert the pendant light into the opening (Fig. 50,1) (light direction either upwards or downwards).
- Connect the cable of the pendant light to the 12 V socket (Fig. 48,1).

5.9.4 Safety guard protection

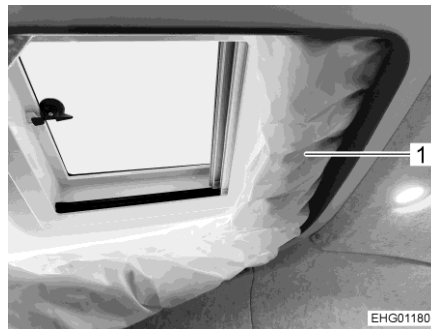

1 Air sack

Fig. 51 Entrance without air sack

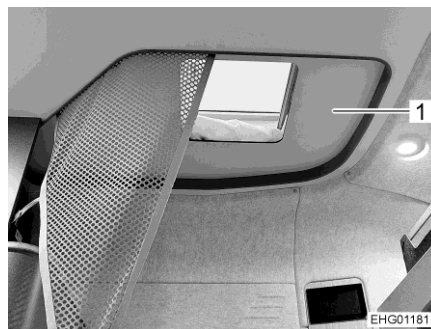

1 Safety guard protection

Fig. 52 Entrance with air sack

The safety guard protection (Fig. 52,1) is inserted into the passage to the sleeping roof and prevents the air sack (Fig. 51,1) of the sleeping roof from hanging inside the vehicle. The safety guard protection must be removed and safely stowed away before climbing into the sleeping roof. The safety guard protection may stay inserted during the journey.

5.9.5 Sleeping roof air chamber repair

Minor damage (max. approx. 2 to 3 cm) to the air chambers of the sleeping roof wall can be repaired with the X GLOO 3DTEX repair kit in order to restore tightness.

The self-adhesive repair material can be used on both the inside and outside.

If a repair is only possible when the sleeping roof wall is raised, the help of a second person is required to apply pressure from the other side of the air chamber.

Preparing the repair:

- Clean the damaged area of the deflated chamber over a large area with the enclosed cleaning cloth. Allow the cleaned area to dry for approx. 3 minutes and do not touch it again.
- Cut the repair sticker so that it overlaps the damaged area by 3 cm on all sides.
- Round off the corners of the repair sticker. Sharp corners will peel off prematurely.

Carrying out the repair:

- Remove the protective film from the repair sticker. Do not touch the adhesive surface.
- Apply the repair sticker to the damaged area without bubbles and press on.



- ▷ Wait at least 2 hours after the repair before refilling the air chamber. The full final strength of the adhesive area is achieved after 24 hours.

Chapter overview

This chapter contains instructions about living in the vehicle.

6.1 Central locking system



- ▷ The central locking system locks the driver's door, the living area door of the body and the rear platform.
- ▷ The central locking system is inoperative when the battery cut-off switch on the transformer/rectifier is switched off.

The locking function of the living area door is powered by the living area battery and is only active when the battery isolator switch on the transformer/rectifier is switched on (see section 8.4).

The battery cut-off switch is switched off for a lay-up of the vehicle. The central locking system then only opens the driver's door (depending on the vehicle, also the front passenger's door). If the vehicle is laid up, the living area door must be unlocked manually using the key.



- 1 "Locking" button
- 2 "Unlocking" button

Fig. 53 Remote control for central locking system

6.2 Doors



- ▶ Only drive with locked doors.



- ▷ Locking the doors can prevent them from opening of their own accord, e.g. during an accident.
- ▷ Locked doors also prevent forced entry, e.g. when waiting at traffic lights. However, in an emergency, locked doors make it more difficult for helpers to enter the vehicle.
- ▷ When leaving the vehicle, always lock the doors.

6.2.1 Living area door, outside

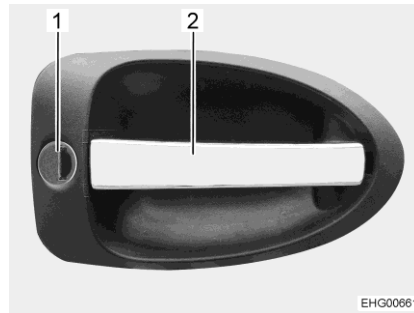

- 1 Locking cylinder
- 2 Door handle

Fig. 54 Door lock (living area door, outside)

- Opening:*
- Insert the key in the locking cylinder (Fig. 54,1) and turn it in a clockwise direction until the door lock is unlatched.
 - Return the key to the central position and remove it.
 - Pull on the door handle (Fig. 54,2). The door is open.
- Locking:*
- Insert the key in the locking cylinder (Fig. 54,1) and turn it in an anti-clockwise direction until the door lock is engaged.
 - Return the key to the central position and remove it.

6.2.2 Electrical closing assist

The living area door is equipped with an electrical closing assist.

- Closing:*
- Close the living area door applying light pressure from the inside or from outside until the lock snaps in once. The electrical closing assist fully closes the living area door. The lock snaps in at the second catch.



- ▷ The closing assist does not lock the door. Locking is done via the central locking system or mechanically on the door lock.

6.2.3 RFID chip

Via the RFID chip, the living area door can be locked and unlocked from outside.



Fig. 55 RFID chip

Locking/unlocking:

- From outside, hold the RFID chip (Fig. 55) close to the sensor in the area of the door handle.



- ▷ If the living area door is locked or unlocked via the RFID chip, a LED on the sensor lights up briefly.
- ▷ The RFID chip does not have any effect on the central locking system of the vehicle!

6.2.4 Living area door, inside

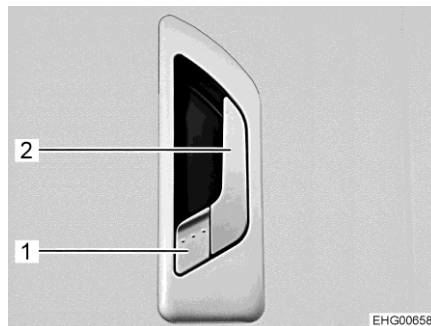

- 1 Door handle, short
- 2 Door handle, long

Fig. 56 Door lock (living area door, inside)

- Opening:*
- When the door lock is locked: Pull the long door handle (Fig. 56,2). The door is unlocked and open.

- Locking:*
- Press the short door handle (Fig. 56,1) of the closed door.

6.2.5 Driver's door, outside

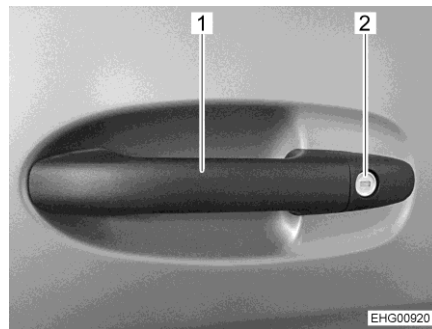

- 1 Door handle
- 2 Locking cylinder

Fig. 57 Door lock (driver's door, outside)

- Opening:**
- Insert the key into locking cylinder (Fig. 57,2) and turn until the door lock is unlatched.
 - Return the key to the central position and remove it.
 - Pull on the door handle (Fig. 57,1). The door is open.
- Locking:**
- Insert the key into locking cylinder (Fig. 57,2) and turn until the door lock is engaged.
 - Return the key to the central position and remove it.

6.2.6 Insect screen on the living area door, extendable



- ▷ Before closing the living area door, fully push in the insect screen.
- ▷ Hold holding bar with both hands when pulling out or pushing in. This prevents the holding bar from jamming in the guides.
- ▷ Do not press any parts of your body or objects into the screen of the insect screen.
- ▷ Keep dogs and cats away from the screen.



- ▷ If there are signs of third party influence or own fault in the case of damage to the screen, the body manufacturer will not accept any guarantee.

- Extending:**
- Hold holding bar with both hands and pull the insect screen evenly out of the door holder.
 - On the opposite side, push the insect screen as far as it will go.
- Pushing in:**
- Hold holding bar with both hands and push the insect screen back into the door holder applying slight pressure.

6.3 External flaps



- ▷ Before commencing the journey, close all external flaps and lock them.
- ▷ To open and close the external flap, open or close all locks that are fitted to the external flap.



- ▷ When leaving the vehicle, close all external flaps.

The external flaps fitted to the vehicle are all fitted with identical locking cylinders. Therefore, all locks can be opened with a single key.

6.3.1 Flap lock, rectangular



- ▷ During rain, water can penetrate the opened flap lock. Therefore close the lock handle.

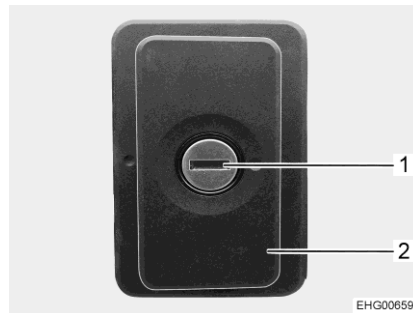

- 1 Locking cylinder
- 2 Lock handle

Fig. 58 Flap lock

- Opening:**
- Insert key into locking cylinder (Fig. 58,1) and turn one half turn in an anticlockwise direction. The lock handle (Fig. 58,2) snaps out.
 - Remove the key.
 - Turn lock handle one half turn in an anticlockwise direction. The flap lock is open.
- Closing:**
- Firmly close the external flap.
 - Give the lock handle one half turn in a clockwise direction. The flap lock is now engaged but not locked.
 - Insert key into locking cylinder.
 - Press down lock handle with key inserted and turn key one half turn in a clockwise direction. The lock handle will stay bolted.
 - Remove the key.

6.4 Ventilation



- ▶ The oxygen in the vehicle interior is used up by breathing and the use of gas operated appliances. Therefore, the used air must be replaced permanently. For this purpose, forced ventilation options (e.g. skylights with forced ventilation) are fitted to the vehicle. Never cover or block forced ventilations from the inside or outside with objects such as e.g. a winter mat. Keep forced ventilations clear of snow and leaves. There is a danger of suffocation due to increased CO₂ levels.



- ▷ Although sufficient ventilation is provided, in certain weather conditions, condensation can form on metal objects (e.g. screwed connections in the floor)
- ▷ Additional cold spots can occur at thermal "bridges" (e.g. skylight edges, sockets, filler necks, flaps, etc.).

Condensation

Ensure that there is a continuous exchange of air by providing frequent and efficient ventilation. This is the only method for ensuring that condensation and resulting mould is not formed during cool weather. During the colder season, a pleasant living climate is created if heating output, air distribution and ventilation are synchronised. To avoid draft close the air outlet nozzles on the dashboard and set the air distribution of the base vehicle to air circulation.

If the vehicle is laid up for a longer period, occasionally ventilate it well, especially in summer as heat accumulation can occur. Do not only air the interior, but also the storage spaces which are accessible from the outside. Air the parking place as well if the vehicle is parked in a closed space (e.g. garage). The occurrence of condensation could lead to the formation of mould.

6.5 Windows



- ▷ The windows are fitted with a blind or Roman shade and with an insect screen or folding insect screen. After the latch has been released, the blind and insect screen automatically spring back to the initial position by tensile force. In order not to damage the tension mechanics, hold onto the blind or insect screen and allow it to slowly return to the initial position. The Roman shade and folding insect screen are made of thin woven fabric. In order not to damage the Roman shade or the insect screen, grasp the respective handle and carefully return it to the initial position.
- ▷ Do not keep blinds closed over a longer period of time as that can cause increased material wear.
- ▷ Grab the bottom rod of the blind by the centre when opening and closing. If the bottom bar is not grabbed by the centre, the blind may jam and be damaged.
- ▷ If the blind or the Roman shade is completely closed, exposure to direct sunlight can cause heat to accumulate between the blind/the Roman shade and the window. The window could be damaged. For that reason, close the blind/Roman shade only 2/3 of the way in direct sunlight. Also move the window into the "continuous ventilation" position.



- ▷ Before commencing the journey, close the windows.
- ▷ Depending on the weather, close the windows far enough to prevent moisture from entering.



- ▷ When leaving the vehicle, always close the windows.
- ▷ In extreme weather conditions or if the temperature fluctuates strongly, a light condensation film can form on the double-glazed acrylic glass. The glass is designed in such a way that condensation can evaporate when the external temperature increases. There is no danger of the double-glazed acrylic glass being damaged by condensation.
- ▷ The upholstery will fade over time, if it is exposed to sunlight. If the temperature within the vehicle rises rapidly as well, the colour will change at an accelerated rate.
Therefore, we recommend to close the shades on the windows when there is strong sunlight. Ensure that heat does not build up when you close the blind.

6.5.1 Hinged window with automatic hinges



- ▷ Open the window completely, to release the lock. If the locking device is not released and the window is closed nevertheless, there is the danger of the window breaking due to the massive counter-pressure.
- ▷ When opening the hinged windows, ensure that there are no torsional forces. Open and close the hinged windows evenly.
- ▷ The catch lever is fitted with a safety knob. When operating the catch lever, always press the safety knob.

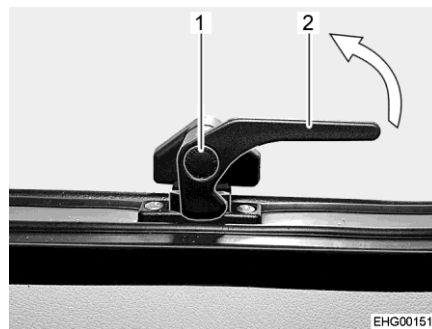

- 1 Safety knob
- 2 Catch lever

Fig. 59 Catch lever ("closed" position)



1 Automatic hinge

Fig. 60 Hinged window with automatic hinge

- Opening:**
- Press the safety knob (Fig. 59,1) and keep it pressed.
 - Turn the catch lever (Fig. 59,2) a quarter turn towards the centre of the window.
 - Open the hinged window to the desired latched position. The automatic hinge (Fig. 60,1) locks in place automatically.

The hinged window remains locked in the required position.

- Closing:**
- Open the hinged window as wide as is necessary to release the lock.
 - Close the hinged window.
 - Press the safety knob (Fig. 59,1) and keep it pressed.
 - Turn the catch lever (Fig. 59,2) a quarter turn towards the window frame. The locking catch on the catch lever is entirely on the inner side of the window lock.

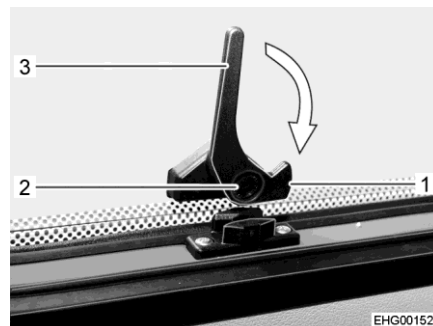

1 Locking catch
2 Safety knob
3 Catch lever

Fig. 61 Catch lever ("open" position)

Continuous ventilation

With the catch lever, the hinged window can be placed in two positions:

- "Continuous ventilation" (Fig. 61)
- "Firmly closed" (Fig. 59)

To place the hinged window into the "continuous ventilation" position:

- Press the safety knob (Fig. 61,2) and keep it pressed.
- Turn the catch lever (Fig. 61,3) a quarter turn towards the centre of the window.
- Lightly open the hinged window outwards.
- Return the catch lever to its initial position. When doing this, introduce the locking catch (Fig. 61,1) on the catch lever into the locking block.

- Release the safety knob (Fig. 61,2).
- Make certain that the safety knob is not pushed in but rather that it secures the catch lever.

During the journey, the hinged window may not be in "continuous ventilation" position.

If it rains, the "continuous ventilation" hinged window position could lead to splashing water penetrating the living area. Therefore, close the hinged windows completely.

6.5.2 Roman shade and insect screen

The windows are fitted with a Roman shade and an insect screen. Roman shade and insect screen are fixed to each other.

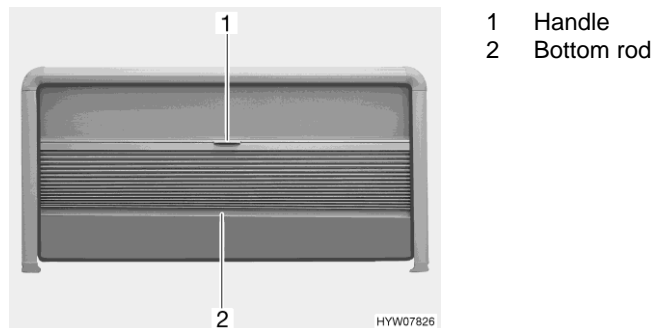

Fig. 62 Roman shade and insect screen (hinged window)

Roman shade The Roman shade is located in the upper window frame.

Closing: ■ Hold the Roman shade in the centre of the bottom rod (Fig. 62,2) and carefully draw it downwards.

Opening: ■ Hold the bottom rod (Fig. 62,2) of the Roman shade in the centre and carefully slide the Roman shade upwards.

Insect screen The insect screen is located in the upper window frame.

Closing: ■ Pull insect screen at the handle (Fig. 62,1) downwards.
 ■ Move the insect screen continuously.

If the insect screen is not drawn fully to the bottom, the Roman shade can be stretched up to the end of the side window frame.

Opening: ■ Move insect screen at the handle (Fig. 62,1) fully upwards.

6.5.3 Roman shade for windscreen, driver's window and front passenger's window



Fig. 63 Locking handle (front passenger's window)



Fig. 64 Roman shade (front passenger's window)

- Closing:**
- Press locking handle (Fig. 63) together and keep it pressed.
 - Pull Roman shade carefully to the opposite side until the magnetic catch holds the Roman shade (Fig. 64) in closed position.
- Opening:**
- Press locking handle (Fig. 63) together and keep it pressed.
 - Using the locking handle, carefully push back the Roman shade.
 - Release the locking handle. The lock must engage.

6.6 Skylights

Depending on the model, skylights with forced ventilation are fitted to the vehicle. If a skylight is fitted without forced ventilation, the forced ventilation is performed using mushroom-shaped vents.



- ▶ The apertures for forced ventilation must always be kept open. Never cover or block forced ventilations with objects such as e.g. a winter mat. Keep forced ventilations clear of snow and leaves.



- ▷ The skylights are fitted with a blind or Roman shade and an insect screen. After the latch has been released, the blind and insect screen automatically spring back to the initial position by tensile force. In order not to damage the tension mechanics, hold onto the blind or insect screen and allow it to slowly return to the initial position.
- ▷ Do not keep blinds closed over a longer period of time as that can cause increased material wear.
- ▷ If the blind or the Roman shade is completely closed, exposure to direct sunlight can cause heat to accumulate between the blind/the Roman shade and the skylight. The skylight could be damaged. For that reason, close the blind/Roman shade only 2/3 of the way in direct sunlight. Open the skylight slightly or move it to ventilation position.
- ▷ Depending on the weather, close the skylights far enough to prevent moisture from entering.
- ▷ Do not climb on the skylights.



- ▷ Before commencing the journey, close the skylights.
- ▷ Before commencing the journey, check that the skylights are closed and locked.



- ▷ When leaving the vehicle, always close the skylights.
- ▷ The upholstery will fade over time, if it is exposed to sunlight. If the temperature within the vehicle rises rapidly as well, the colour will change at an accelerated rate.
Therefore, we recommend closing the shades on the skylights of the parked vehicle by 2/3 when there is strong sunlight.

6.6.1 Hinged skylight

The hinged skylight may be opened on one side only. Three inclination angles and a ventilation position are available.

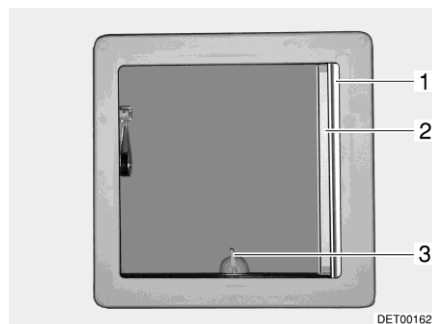

- 1 Roman shade
- 2 Insect screen
- 3 Lever

Fig. 65 Hinged skylight

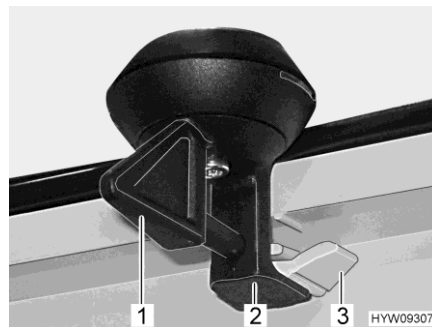

- 1 Lever
- 2 Lock
- 3 Catch

Fig. 66 Lock (hinged skylight)

- Opening:**
- Turn the lever (Fig. 65,3 or Fig. 66,1) one quarter turn.
 - Grip lever and push hinged skylight upwards.
- Closing:**
- Grip lever and pull hinged skylight downwards.
 - Turn the lever one quarter turn. The lock (Fig. 66,2) must slide into the bottom catch (Fig. 66,3).

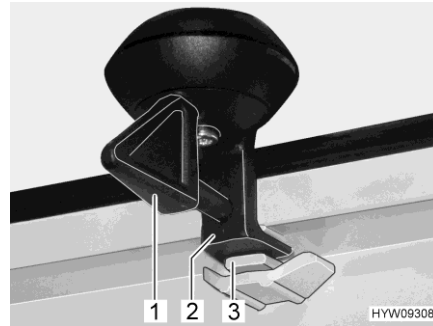

- 1 Lever
- 2 Lock
- 3 Recess

Fig. 67 Lock (ventilation position)

Locking in the ventilation position:

- Grip lever and pull hinged skylight downwards.
- Turn the lever (Fig. 67,1) one quarter turn. The lock (Fig. 67,2) must slide into the top recess (Fig. 67,3).



- ▷ If it rains and the hinged skylight is in ventilation position, that could lead to water penetrating the living area. Therefore close hinged skylight completely.

Roman shade

The Roman shade may be closed at any position, either with the hinged skylight open or closed.

Closing:

- Pull out Roman shade (Fig. 65,1) and release in the required position. The Roman shade will stay in that position.

Opening:

- Slowly push Roman shade at the handle to its initial position.

Insect screen



- ▷ The insect screen may be damaged if it is closed with the hinged skylight closed. Therefore only close the insect screen when the hinged skylight is open.

Closing:

- Pull insect screen (Fig. 65,2) out until it engages with the latch on the opposite side.

Opening:

- Slightly push up insect screen along the strip. Latch is released.
- Slowly return insect screen into its initial position.

6.6.2 Skylight with fan (optional)



▷ To save the battery, after one hour the fan automatically switches from level 6 down to level 1.

The skylight is equipped with an insect screen, blind and an adjustable fan for aerating and venting.

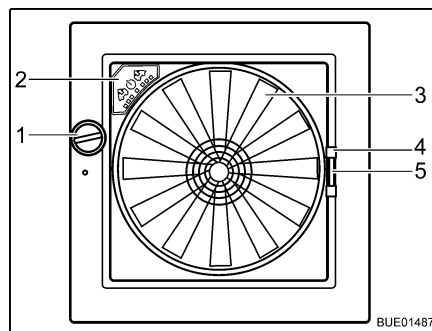

- 1 Knob
- 2 Operating panel
- 3 Fan
- 4 Handle (insect screen)
- 5 Handle (shade)

Fig. 68 Omni-Vent skylight

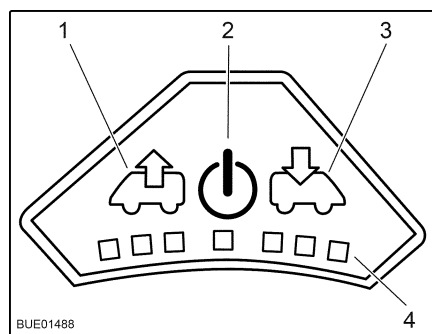

- 1 Vent button
- 2 On/Off button
- 3 Aerate button
- 4 LEDs

Fig. 69 Control panel for fan

Opening: ■ Turn the knob (Fig. 68,1) until the desired opening angle is reached.

Closing: ■ Turn the knob (Fig. 68,1) until the skylight is fully closed.

Insect screen To close and open the insect screen:

Closing: ■ Use the handle (Fig. 68,4) to pull the insect screen across to the other side of the frame.

Opening: ■ Press the handle of the insect screen together. The latch is released.
 ■ Use handle to return the insect screen slowly to its initial position.

Shade To close and open the shade:

Closing: ■ Press together the handle (Fig. 68,5) of the shade.
 ■ Pull out the shade to the desired position and release. The shade will stay in that position.

Opening: ■ Press together the handle of the shade.
 ■ Slowly return the shade to its initial position.

- Fan** If the skylight is open, the interior can be vented and aerated with the 6-speed fan (Fig. 68,3). The fan is operated via the operating panel (Fig. 68,2).
- Switching on:**
- Press the On/Off button (Fig. 69,2). The fan runs in comfort mode (venting at slowest fan speed).
- Venting:**
- To increase the fan speed: Press the Vent button (Fig. 69,1). The fan speed in the venting direction increases by one level. LEDs (Fig. 69,4) show the operating levels.
 - To lower the fan speed: Press the Aerate button (Fig. 69,3). The fan speed decreases by one level.
- Aerating:**
- To increase the fan speed: Press the Aerate button (Fig. 69,3). The fan speed in the aerating direction increases by one step. LEDs (Fig. 69,4) show the operating levels.
 - To lower the fan speed: Press the Vent button (Fig. 69,1). The fan speed decreases by one level.
- Switching on the boost function:**
- Press and hold the Aerate button for approx. 3 seconds. The fan switches to the maximum aeration level and then, after approximately 5 minutes, automatically switches back to the previously selected level.
 - Press and hold the Vent button for approx. 3 seconds. The fan switches to the maximum venting level and then, after approximately 5 minutes, automatically switches back to the previously selected level.
- Switching off:**
- Press the On/Off button (Fig. 69,2). The fan stops, the LEDs go out.

6.7 Storage spaces



- ▶ Follow the safety instructions (sticker) that indicate when a space may not be used as a storage space (e.g. gas bottle compartment or spaces close to electrical wiring).
- ▶ When loading, observe the technically permissible maximum laden mass on the front and rear axle and the technically permissible maximum laden mass (see section 3.2.3).
- ▶ Do not transport fluids in the living area that emit gases hazardous to health.
- ▶ Close fluid containers tightly, secure them against sliding and against falling over.
- ▶ Always store heavy objects safely and slip-proof in the foot area. Lighter objects can be also stored safely in higher areas.



- ▷ Do not store wet clothes in cabinets or storage spaces.



- ▷ While storing the load, take into account how accessible the different objects should be, and how often they are used.

In the vehicle, there are the following possibilities for storage:

- Double floor area (interior and exterior access)
- Storage cases
- Hanging shelves

6.7.1 Furniture flaps with comfort push button



Fig. 70 Comfort push button with leather loop

- Opening:*
- Press the push button (Fig. 70). The push button jumps out.
 - Grasp the leather loop and open the furniture flap.
- Closing:*
- Press the furniture flap shut.
 - Press push button in until it locks. The furniture flap is closed correctly when the fastener locks into place.

6.7.2 Service cover in the floor

The service covers are accessible from the living area. The arrangement depends on the model.

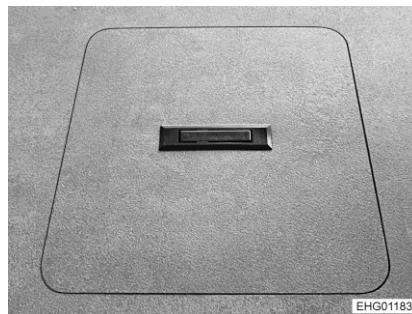

Fig. 71 Service cover (handle recessed)



Fig. 72 Service cover (handle swivelled out)

- Opening:*
- Push one side of the handle plate (Fig. 71) downwards. The handle (Fig. 72) swivels upwards.
 - Remove the service cover upwards.



- ▶ Close the service cover again as soon as possible and recess the handle. Otherwise, there will be danger of tripping due to the open floor storage compartment or the protruding handle.

- Closing:*
- Insert the service cover in the frame in the floor.
 - Swivel handle downwards.

6.7.3 Multifunctional wall



- ▷ Before commencing the journey, remove all hook-in elements and store them securely.

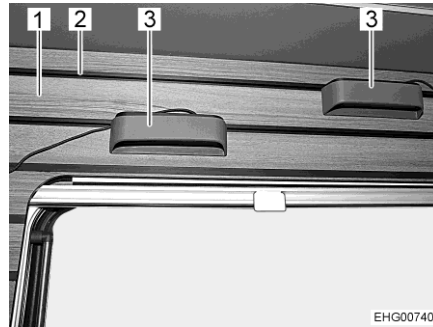

- 1 Multifunctional wall
- 2 Aluminium profile
- 3 Reading lamp

Fig. 73 Multifunctional wall with reading lamps

The living area of the vehicle is equipped with multifunctional walls in bamboo look in several places.

The multifunctional walls have aluminium profiles to which various hook-in elements can be attached.

Examples of hook-in elements (selection):

- Reading lamp
- Herb pot
- Coat hook
- Shelf



- ▷ The hook-in elements are available as accessories in the after-sales service.

6.7.4 Underfloor installation compartment



- ▷ The maximum load of the underfloor installation compartment including the incorporated installation is 90 kg.

6.8 Fixing rails on the roof (Airlines)

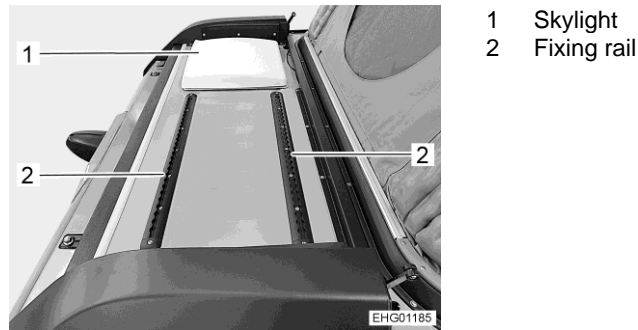

Fig. 74 Fixing rails on the roof (Airlines)

Fixing rails (Airlines) (Fig. 74,2) are fitted on the roof in the rear area next to the skylight (Fig. 74,1). Additional luggage with a maximum weight of 30 kg can be transported on these fixing rails.

6.9 Tables

6.9.1 Table in the living area



▷ Before commencing the journey, store the table in parking position.

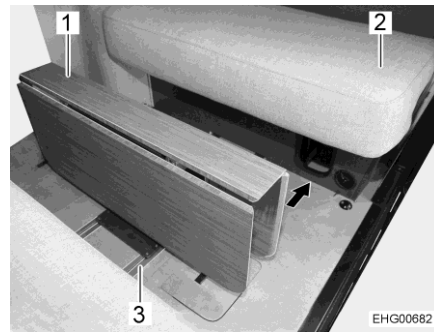

Fig. 75 Table top release lever

The two halves of the table top can be folded down independently of each other. In addition, the table can be lowered and used as a bed foundation.

Converting to a bed foundation:

- Press both release levers (Fig. 75) on the underside of the table top half simultaneously and swing the table top half down.
- Unlock the second table top half in the same way and swing it down.
- Lift the table slightly to release the lock and then push the table all the way down.



- 1 Table
- 2 Seat cushion
- 3 Rail

Fig. 76 Table (folded and lowered)

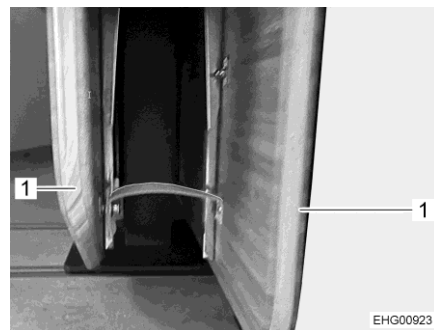

- 1 Table top

Fig. 77 Table tops secured

Storing the table in transport position:

- Fold and lower the table as described above.
- Fix the table tops (Fig. 77,1) (see Fig. 77).
- Slide the table (Fig. 76,1) to the right-hand bench on the rails (Fig. 76,3) in the vehicle floor. In order to do this, press against the table leg.
- Lift the seat cushion (Fig. 76,2) of the right-hand bench.
- Slide the table under the seat cushion.
- Lower the seat cushion onto the table so that the table is secured by the seat cushion.

Setting up the table:

- Lift the seat cushion of the right-hand bench.
- Pull the table towards the centre of the vehicle on the rails in the vehicle floor. In order to do this, pull the table leg.
- Pull the table upwards until it engages audibly.
- Swivel the table top halves downwards until the lock engages.

6.9.2 Secretary, foldable

A folding secretary is built into the tall cupboard behind the front passenger's seat.

Features of the secretary:

- Two-part bamboo work top
- Goose neck reading lamp
- 230 V socket
- USB socket

The front passenger's seat serves as a seat for the secretary. The front passenger's seat must be turned 180° for this purpose.

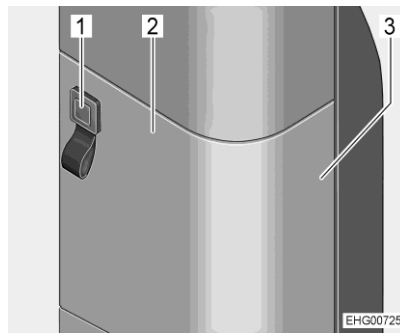

- 1 Push button
- 2 Centre cupboard door
- 3 Tall cupboard

Fig. 78 Tall cupboard

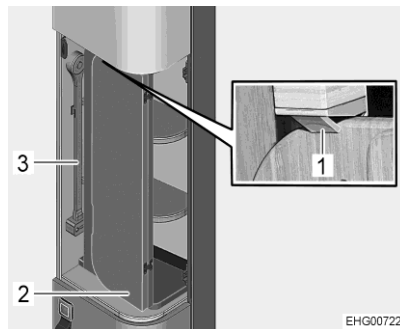

- 1 Holder
- 2 Work top (two-part)
- 3 Goose neck reading lamp

Fig. 79 Secretary (folded)



▷ Before opening the secretary, make sure that the centre cupboard door on the tall cupboard (Fig. 78,3) is fully open. Otherwise, the two-part work top cannot be folded out.

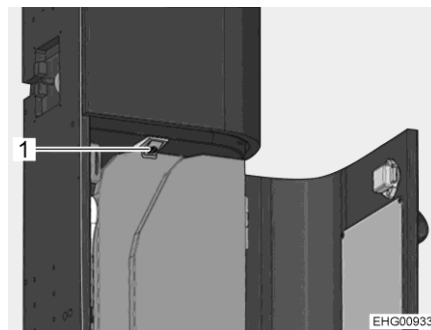

- 1 Holder

Fig. 80 Unlocking the secretary

- Unlock the holder (Fig. 80,1) of the work top.

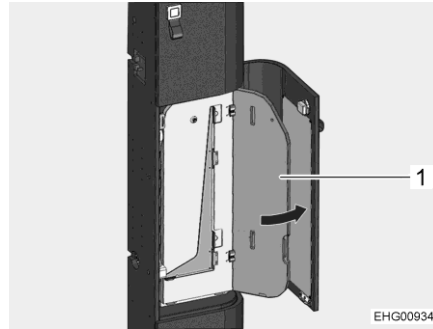

1 Work top

Fig. 81 Folding out the secretary work top

- Fold out the work top (Fig. 81,1).

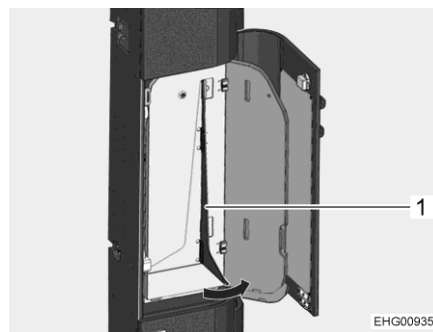

1 Support

Fig. 82 Folding out the support

- Fold out the support (Fig. 82,1) of the work top.

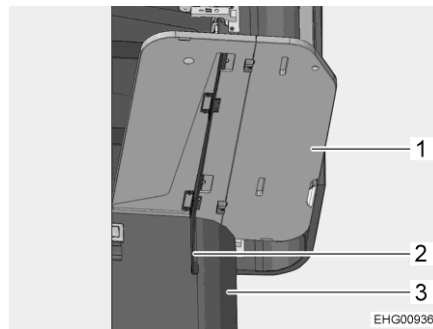

1 Work top
2 Support
3 Furniture door

Fig. 83 Folding down the secretary work top

- Swing the work top (Fig. 83,1) down and support it with the support (Fig. 83,2) on the furniture door (Fig. 83,3).

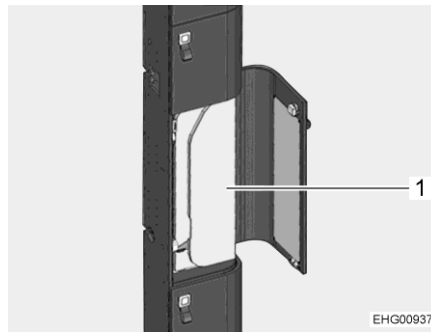

1 Work top

Fig. 84 Folding in the secretary

- To fold in, proceed in reverse order. When doing this, slide the worktop (Fig. 84,1) behind the holders.

6.9.3 Work top extension



- ▷ Before commencing the journey, remove the work top extension and store it securely.

An attachable work top extension can be used to create additional storage and work space in the kitchen. The work top extension is fitted above a drawer next to the stairs.

When the work top extension is not in use, it can be stowed away in the storage compartment.

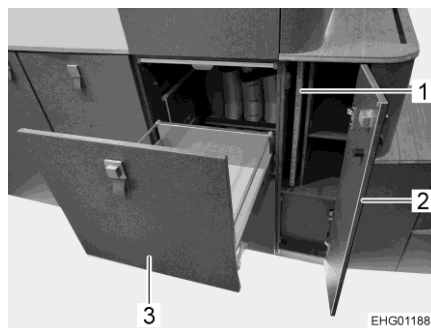

1 Work top extension
2 Storage compartment
3 Drawer

Fig. 85 Storage compartment / drawer

Installing the work top extension:

- Open the storage compartment (Fig. 85,2).
- Take the work top extension (Fig. 85,1) out of the storage compartment.
- Close the storage compartment.
- Pull the drawer (Fig. 85,3) out completely.

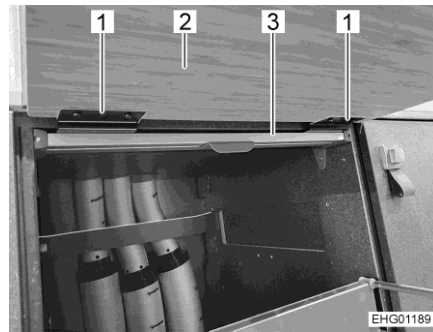

- 1 Angle bracket
- 2 Work top extension
- 3 Aluminium profile

Fig. 86 Angle bracket

- Insert the two angle brackets (Fig. 86,1) of the work top extension (Fig. 86,2) above the aluminium profile (Fig. 86,3).

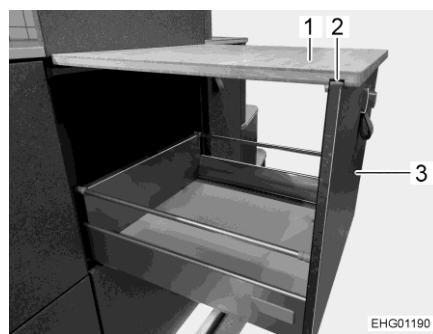

- 1 Work top extension
- 2 Groove
- 3 Drawer

Fig. 87 Groove (work top extension)

- Place the work top extension (Fig. 87,1) on the drawer (Fig. 87,3) so that the front panel of the drawer engages in the groove (Fig. 87,2) of the work top extension.

Removing the work top extension:

- Slightly lift the work top extension (Fig. 87,1).
- Detach the work top extension (Fig. 86,2) from the aluminium profile (Fig. 86,3). To do this, pull the two angle brackets (Fig. 86,1) off the aluminium profile.
- Slide the worktop extension (Fig. 85,1) into the storage compartment (Fig. 85,2).
- Close the storage compartment.
- Close the drawer (Fig. 85,3).

6.10 Lighting

Several LED strips (ambient lighting) and recessed spotlights (work lights) are installed in the vehicle. In addition, pendant lights and reading lamps can be attached in different places as required (power supply via light sockets).

The entire lighting can be individually controlled via the HYMER Connect app or the 7" panel, and different lighting scenarios can be saved.

In addition, multiple light switches (Fig. 88) are installed at various points in the vehicle with which the lamps can be switched on and off individually.

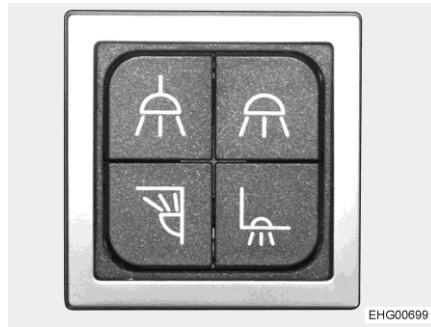

Fig. 88 Multiple light switch (example)

The meaning of the switch symbols of the multiple light switches is explained in the table below.

Switch symbol	Signification
	Main light switch (switches off the entire lighting)
	Pendant light
	Recessed spotlights / entrance light / LED strips in the sleeping roof
	Kitchen plinth lighting / canopy lighting
	Lamp in the step well / kitchen work light / LED strip, awning (optional)
	Staircase lighting

Operation The light switches can be used to switch the lamps on and off and dim them.

- Switch on the lamp: briefly press the light switch.
- Dim the lamp: press the light switch and keep it pressed until the desired brightness is reached. The change in brightness is always continued in the same way as the last setting made. To reverse the "direction", release the switch briefly, press again and hold until the desired brightness is reached.
- Switch off the lamp: briefly press the light switch.

6.10.1 Pendant light



- ▷ Before commencing the journey, remove the pendant light and store it securely.

The pendant light can be mounted in different places in the vehicle as required:

- On the ceiling above the seating group in the living area
- In an opening in the floor of the sleeping area

When the pendant light is used in the opening in the floor of the sleeping area, it can optionally be mounted such that it shines upwards or downwards.



Fig. 89 Pendant light

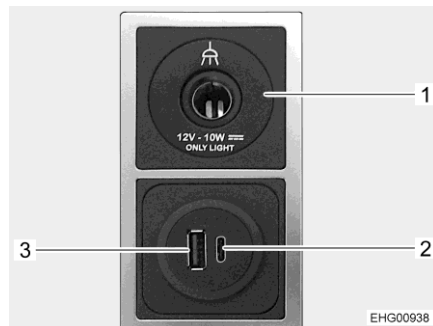

- 1 12 V socket
- 2 USB C port
- 3 USB A port

Fig. 90 Combination socket for lamps and USB

- Install the pendant light (Fig. 89) at the desired location.
- Connect the cable of the pendant light to the nearest 12 V socket (Fig. 90,1).
- Switch on the pendant light at the associated light switch (symbol:).



- ▷ Other pendant lights can be added as desired as original accessories from the after-sales service. All pendant lights are switched via one switch.

6.10.2 Mobile reading lamp



- ▷ Before commencing the journey, remove the mobile reading lamps and store them securely.

Mobile reading lamps can be attached to the hanging rails of the multifunctional wall as desired.

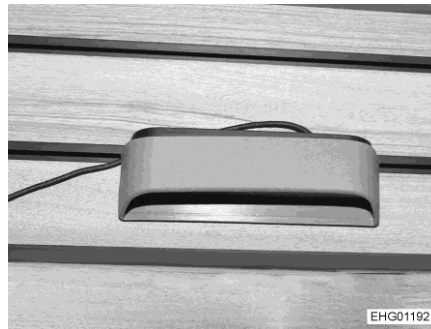

Fig. 91 Mobile reading lamp

- Attach the mobile reading lamp (Fig. 91) to one of the hanging rails at the desired location.
- Connect the cable of the reading lamp to the nearest 12 V/USB combination socket (Fig. 90).
- Switch on the mobile reading lamp at the associated switch.



- ▷ Other mobile reading lamps can be added as desired as original accessories from the after-sales service.

6.10.3 Goose neck reading lamp on the secretary

The folding secretary behind the front passenger's seat is equipped with a goose neck reading lamp with USB port in the base.



1 Switch

Fig. 92 Goose neck reading lamp

- Move the goose neck reading lamp to the desired position.
- Press the switch (Fig. 92,1) at the top of the lamp head of the goose neck reading lamp.

6.11 Conversion of seating group into additional bed

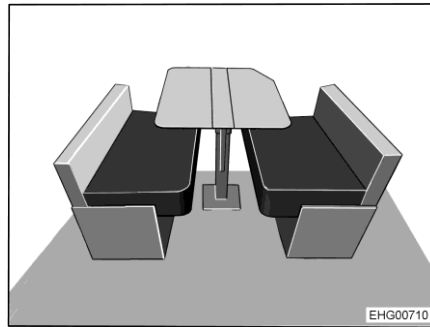

Fig. 93 Prior to conversion

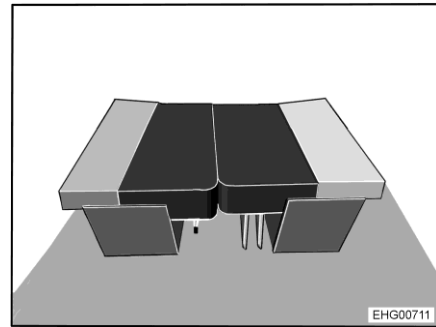

Fig. 94 After conversion

- Fold down the table top halves and lower the table (see section 6.9.1).
- Slide the table on the rails in the vehicle floor slightly towards the right-hand bench. In order to do this, press against the table leg.
- Lift the seat cushion of the right-hand bench, pull it to the centre and place it on the table.
- Lift the seat cushion of the left-hand bench, fold out the support legs, pull the seat cushion to the centre and set it down.
- Remove the back cushions of the right-hand and left-hand benches. In order to do this, pull the loop (at the bottom of the back cushion) until the back cushion is detached from its fastening.
- Insert the back cushions between the seat cushion and the exterior wall, respectively (Fig. 94).

Chapter overview

This chapter contains instructions regarding the gas system of the vehicle. The operation of the gas operation appliances of the vehicle is described in chapter 9.

7.1 General instructions



- ▶ The operator of the gas system is responsible for the performance of recurring inspections and for complying with the maintenance intervals.
- ▶ Before commencing the journey, when leaving the vehicle or when the gas devices are not in use, close all gas isolator taps and the main regulator tap on the gas bottle.
- ▶ When refuelling, on ferries or in the garage, all gas/diesel-operated devices must be switched off. Danger of explosion!
- ▶ Do not use gas-operated devices in closed spaces (e.g. garages). Danger of poisoning and suffocation!
- ▶ Only have the gas system maintained, repaired or altered by an authorised specialist workshop.
- ▶ Have the gas system checked by an authorised specialist workshop according to the national regulations before commissioning. This also applies for not registered vehicles. For modifications to the gas system have the gas system immediately checked by an authorised specialist workshop.
- ▶ The gas pressure regulator, the gas tubes, and the exhaust gas pipes must also be inspected. The gas pressure regulator and the gas tubes must be replaced observing the nationally defined deadlines (the latest after 10 years). The vehicle owner is responsible for seeing that this is carried out.
- ▶ In case of a defect of the gas system (gas odour, high gas consumption) there is danger of explosion! Close regulator tap on the gas bottle immediately. Open doors and windows and ventilate well.
- ▶ If the gas system is defective: Do not smoke; do not ignite any open flames, and do not operate electric switches (light switches etc.). Check the tightness of gas-conducting parts and lines with leakage search spray. Do not check with an open flame.
- ▶ Only the stipulated devices may be connected to internal connections. Do not operate any device outside the vehicle if it is connected to an internal connector.
- ▶ Before using the cooker make sure that there is sufficient ventilation. Open a window or the skylight.
- ▶ Cooking is prohibited during the journey.
- ▶ Do not use gas-operated cooking and baking equipment for heating purposes.
- ▶ When the cooker is not in use: close the gas isolator tap on the cooker and the regulator tap on the gas bottle and fit the protective cap.
- ▶ Ignition safety valves must close within 1 minute after the gas flame has extinguished. A clicking sound is audible. Check function from time to time.



- ▶ The built-in gas devices are exclusively meant for use with propane or butane gas or a mixture of both. The gas pressure regulator as well as all built-in gas devices are designed for a gas pressure of 30 mbar.
- ▶ Propane gas is capable of gasification up to -42 °C, whereas butane gas gasifies at 0 °C. Below these temperatures no gas pressure is available. Butane gas is unsuitable for use in winter.
- ▶ Due to its function and construction, the gas bottle compartment is a space which is open to the exterior. Never cover or block up the standard forced ventilations. Otherwise gas that is emitted can not be diverted to the outside.
- ▶ The gas bottle compartment must not be used as storage space.
- ▶ Secure the gas bottle compartment against unauthorised access. To do this, lock the compartment.
- ▶ The regulator tap on the gas bottle must be accessible.
- ▶ Only connect gas-operated devices which have been designed for a gas pressure of 30 mbar.
- ▶ The exhaust gas pipe must be fitted tightly to the heating system and to the vent and must be sealed. The exhaust gas pipe must not show any evidence of damage.
- ▶ Exhaust fumes must be able to escape into the atmosphere unhindered and fresh air must be able to enter unhindered. For this reason, keep the exhaust pipe and intake openings clean and unobstructed (e.g. free from snow and ice). For this reason, no snow walls or aprons may lie against the vehicle.

7.2 Gas bottles



- ▶ Handle full or emptied gas bottles outside the vehicle only with closed regulator tap and attached protective cap.
- ▶ Gas bottles are only to be transported within the designated gas bottle compartment.
- ▶ Place the gas bottles in vertical position in the gas bottle compartment.
- ▶ Fasten the gas bottles so that they are unable to turn or tilt.
- ▶ Connect the gas tube to the gas bottle without tension.
- ▶ If the gas bottles are not connected to the gas tube, always place the protective cap on top.
- ▶ Close the regulator tap on the gas bottle before the gas pressure regulator or gas tube are removed from the gas bottle.
- ▶ Depending on the connection, unscrew the gas tube from the gas bottle and screw it on the gas bottle again by hand or using a suitable special spanner. The screw connection on the gas bottle generally has a left-hand thread. First hand-tighten, then use the gas bottle spanner from the accessories shop.
- ▶ Only use special gas pressure regulators with a safety valve designed for vehicle use. Other gas pressure regulators are not permitted and cannot meet the demanding requirements.



- ▶ Use the gas pressure regulator defroster (EisEx) if the temperature falls below 5 °C.
- ▶ Use maximum 5 kg gas bottles. (The size of the gas bottles may vary depending on the country.)
- ▶ Never block the floor ventilation openings below the gas bottles.



- ▷ The screw connections on the gas bottles generally have a left-hand thread.
- ▷ For gas-operated units the gas pressure must be reduced to 30 mbar.
- ▷ Connect gas pressure regulator complete with safety valve directly to bottle valve.
- ▷ The gas pressure regulator reduces the gas pressure in the gas bottle down to the operating pressure of the gas devices.
- ▷ For filling and connecting the gas bottles in Europe the accessories shops have corresponding Euro filling sets and Euro bottle sets.
- ▷ Information available at the dealers or service centre.

7.3 Gas isolator tap

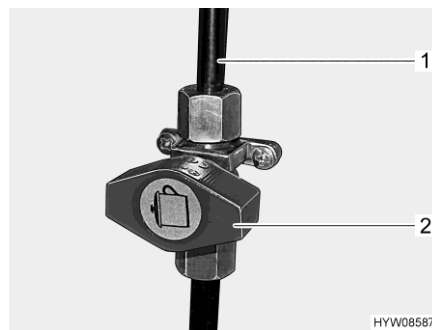

- 1 Pipe
- 2 Gas isolator tap

Fig. 95 Gas cooker gas isolator tap

A gas isolator tap (Fig. 95,2) is fitted to the gas cooker in the vehicle. The gas isolator tap is located underneath the sink.

- Opening:**
- Turn the gas isolator tap so that it is in the vertical position, parallel to the pipe (Fig. 95,1) that runs to the gas cooker.
- Closing:**
- Turn the gas isolator tap so that it is at 90 degrees to the pipe (Fig. 95,1) that runs to the gas cooker (Fig. 95).

7.4 External gas connection (optional)



- ▶ Only gas appliances with a suitable adapter should be connected to the external gas connection.
- ▶ Connect only external gas appliances which are designed for an operation pressure of 30 mbar.
- ▶ Once you have made the connection and opened the gas isolator tap, make sure that no gas is escaping at the connection point. If there is a leak in the external gas connection, gas will escape into the open air. Immediately close the gas isolator tap and the regulator tap on the gas bottle. Have the external gas connection checked by an authorised specialist workshop.
- ▶ When connecting an external gas appliance, make sure that there is nothing near the external gas connection that could cause a spark.
- ▶ Only connect a gas appliance to the external gas connection. Do not use the external gas connection as supply (connection of an additional gas bottle).
- ▶ Do not use the external gas connection to fill gas bottles. Observe the information stickers on the external gas connection.

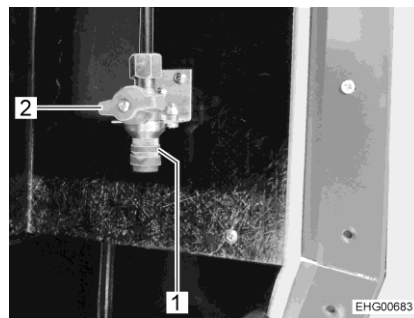

- 1 Connection point
- 2 Gas isolator tap

Fig. 96 External gas connection
(gas isolator tap closed)

The external gas connection is installed in the gas bottle compartment (on the right-hand side of the vehicle).

- Connect the external gas device to the connection point (Fig. 96,1).
- Open the gas isolator tap (Fig. 96,2).

7.5 Changing gas bottles



- ▶ When changing gas bottles, do not smoke or create any open fire.
- ▶ After changing the gas bottles, check whether gas is leaking at the connection points. To do this, spray the connection point with leakage search spray. These agents are available at the accessories shop.

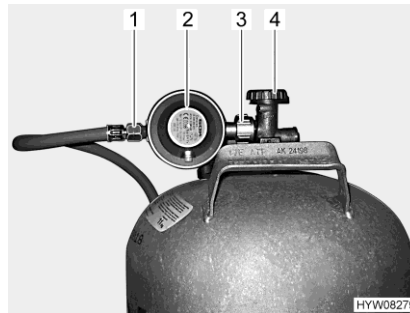

- 1 Gas tube
- 2 Gas pressure regulator
- 3 Knurled nut
- 4 Regulator tap

Fig. 97 Gas bottle connection

- Open flap for the gas bottle compartment.
- Close the regulator tap (Fig. 97,4) on the gas bottle. Pay attention to the direction of the arrow.
- Hold the gas pressure regulator (Fig. 97,2) and open the knurled nut (Fig. 97,3) (normally a left-hand thread).
- Remove the gas pressure regulator and the gas tube (Fig. 97,1) from the gas bottle.
- Release the fixing belts and remove the gas bottle.
- Place a filled gas bottle in the gas bottle compartment.
- Fix gas bottle in place with the fixing belts.
- Position the gas pressure regulator (Fig. 97,2) with gas tube (Fig. 97,1) on the gas bottle and tighten the knurled nut (Fig. 97,3) (normally a left-hand thread). First, hand-tighten, then use the gas bottle spanner from the accessories shop.
- Close flap for the gas bottle compartment.

Chapter overview

This chapter contains instructions regarding the electrical system of the vehicle.

The operation of the electrical appliances of the housing body is described in chapter 9.

8.1 General safety instructions



- ▶ Only allow qualified personnel to work on the electrical system.
 - ▶ All electrical devices (e.g. mobile phones, radios, televisions or DVD players) that are retrofitted into the vehicle and operated during the journey must have a CE marking and be verifiably tested according to DIN VDE 0100 721. Please contact an authorised specialist workshop.
- Only in this way can the functional reliability of the vehicle be ensured. Otherwise the airbag may be triggered or interference to the on-board electronics may result.



- ▷ After the vehicle is started, delays to the output or forwarding of electrical impulses are possible.
The control unit of the basic vehicle does not release the D+ signal until the engine has reached full performance. In the event of a cold start in winter, this can take up to 15 seconds.
For this reason, output of warning signals (such as "entrance step extended") may sometimes be delayed.
The automatic retraction of a SAT antenna can also be delayed.
- ▷ During a storm, to protect the electrical devices disconnect the 230 V connection and retract the antennae.

8.2 Terms

Off-load voltage

The off-load voltage is the voltage of the battery in idle condition, i. e. no current is consumed and the battery is not being charged.



- ▷ The battery must remain idle for a while before measuring. After charging the last time, or after the last current has been drained by appliances, wait approximately 2 hours before measuring the off-load voltage.

Closed circuit current

Some electrical appliances, such as indicator lamps, TV unit or USB sockets, require electrical current all the time; that is why they are also referred to as inactive appliances. This closed circuit current flows even if the device has been switched off.

Total discharge Total discharge of the battery is imminent, if a battery is completely discharged by an active appliance and by closed circuit current and the off-load voltage falls below 12 V.



- ▷ Total discharge damages the battery.

Capacity Capacity refers to the amount of electricity which can be stored in a battery. The capacity of a battery is given in ampere hours (Ah). The so-called K20 value is normally used.

The K20 value indicates how much current a battery can deliver over a period of 20 hours without being damaged.

For example, if a battery can dispense 4 amps for 20 hours, then it has a capacity of 4 A x 20 h = 80 Ah.

If more current flows, the discharging time of the battery will decrease proportionately.

External influences, such as temperature and age may alter the storage capacity of the battery. Capacity details refer to new batteries operating at room temperature.



- ▷ Depending on battery technology, capacity details have a conversion factor of 1.3 to 1.7, which lowers the real capacity by this value.
- ▷ A practical example is shown in section 8.3.4.

8.3 12 V power supply



- ▷ Only connect devices with a maximum of 10 A to the sockets of the 12 V power supply.
- ▷ Connect only devices with a maximum of 2.5 A to the USB sockets.

8.3.1 Sockets

Various sockets for operation and charging of electrical appliances are installed in the vehicle. The sockets can be built in individually or as a combination.



- 1 12 V socket
- 2 USB C port
- 3 USB A port

Fig. 98 Combination socket
12 V/USB

- USB socket** The vehicle is equipped with several USB sockets as standard. The USB sockets each contain a connection for a USB A plug (Fig. 98,3) and a connection for a USB C plug (Fig. 98,2). The USB sockets can be used to charge the batteries of devices with a charging current of up to 3.6 A.

- 12 V socket** The 12 V socket (Fig. 98,1) can be used to connect mobile reading lamps and pendant lights.
 Only a mobile reading lamp / pendant light from Hymer may be connected to the 12 V socket (Fig. 98,1). Devices from other manufacturers may be damaged.

- 230 V socket** The 230 V socket can be used to connect standard household appliances.

8.3.2 Starter battery

The starter battery serves for starting the engine and supplies the electrical appliances of the base vehicle as well as optional devices such as the radio, navigation system or central locking system with voltage.



- ▷ Total discharge damages the battery. The consequence may be deformation, heat development, and damage due to scorching.
- ▷ Once a battery with acid is discharged, it can freeze in temperatures of below zero. This damages the battery.
- ▷ Recharge battery in good time.

The starter battery will be totally discharged via a closed circuit current (inactive appliances). Inactive appliances are optional devices such as a radio, alarm system, navigation system or a central locking system. Inactive appliances discharge the starter battery when the vehicle engine is switched off. Low temperatures outside reduce the capacity available.

- Charging** Safety instructions and information on charging the starter battery, see instruction manual of the base vehicle.

- Position** The starter battery is fitted in the footwell of the driver's cabin under the floor plate.

8.3.3 Living area battery (*HYMER* Smart Battery System)

The *HYMER* Smart Battery System with four lithium batteries is installed in the vehicle.



- ▷ Do not make any changes to the installation of the living area battery carried out at the factory.
- ▷ Do not open the living area battery.
- ▷ Observe the recommended operating temperature between 15 and 25 °C. Take any further details on the operating temperature from the manufacturer's instruction manual.
- ▷ Fully charge the battery system every 6 months.



- ▷ Switch the transformer/rectifier off for installation and maintenance.
- ▷ Remove the fuses between starter battery and living area battery for installation and any work on the wiring.
- ▷ If the battery capacity indicator does not reach 100 % any more after a longer charging time, contact the customer service.
- ▷ Transport and dispose of the living area battery only as prescribed by the manufacturer.
- ▷ Observe the manufacturer's instruction manual.
- ▷ Prior to commencing a journey ensure the living area battery is completely charged. Charge the living area battery for at least 20 hours before commencing the journey.
- ▷ During the trip, use every opportunity to charge the living area battery.
- ▷ After the trip, charge the living area battery completely.
- ▷ Fully charge the living area battery before and after a lay-up.
- ▷ Disconnect the living area battery from the 12 V power supply when the vehicle is not in use and check the voltage regularly.

The living area battery has a service life of up to 10 years if used correctly. It is equipped with a protection function against overloading and deep discharge.

When the vehicle is not connected to the 230 V power supply or the 230 V power supply is switched off, the living area battery supplies the living area with 12 V DC. The living area battery has a limited power supply only. For this reason, electrical appliances such as the radio and the lights should not be operated for a long time without using the 230 V power supply.

Technical data of the living area battery

Nominal voltage	12.8 V DC
Battery cells	LiFePO4
Usable lithium capacity	80 Ah/1024 Wh
Number of cycles at a temperature range between 1 °C and 25 °C	3000 full cycles (then 80 % residual capacity)
Number of cycles at a temperature range between 0.3 °C and 25 °C	> 5000 full cycles (then 80 % residual capacity)
Continuous charge/discharge current	Max. 80 A
Weight	9.9 kg
Operating temperature (charging)	-30 °C to +60 °C (integrated heater active between -30 °C and +10 °C)
Operating temperature (discharging)	-20 °C to +60 °C
Protection functions	Overcurrent, overvoltage, short circuit, overcharge, deep discharge, reverse polarity protection, temperature protection

Position The living area battery is installed underneath the floor trap behind the driver's / front passenger's seat.

Display The voltage and charge data of the battery system are displayed on the 7" panel.

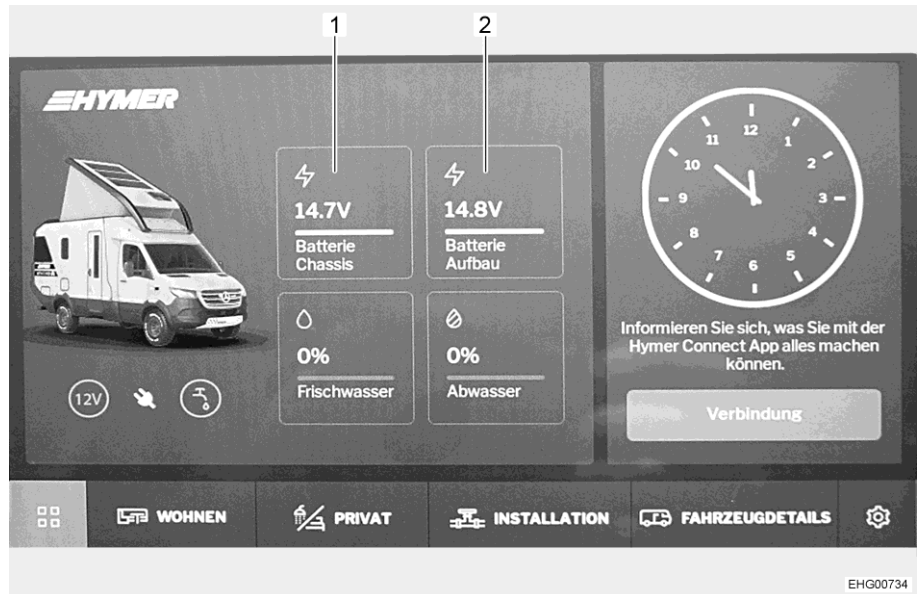

Fig. 99 Start screen of the 7" panel

- 1 Starter battery voltage indicator
- 2 Living area battery voltage indicator

The start screen shows the voltage of the starter battery (Fig. 99,1) and the status of the living area battery (Fig. 99,2).

By navigating the display, further information on the starter battery and the living area battery can be called up.

Display of total state of charge (SoC)

The total state of charge is displayed on the 7" panel and in the main menu Vehicle details (Fig. 99) under BOS battery. The total state of charge is referred to as the "State of Charge" (SoC). The value of the SoC is displayed as a percentage and, additionally, as a bar chart.

Charging

Only use the installed transformer/rectifier to charge the living area battery. Therefore, connect the vehicle to an external 230 V power supply system as often as possible. As a principle, only use the 230 V connection on the vehicle (CEE socket outlet) for connecting.

Fully charge the battery system after recommissioning or longer periods of inactivity.



- ▷ At temperatures below 0 °C, the living area battery consumes less power. At approx. -15 °C, there will be no more power. The living area battery can no longer be charged.



- ▷ If the living area battery is charged via an "intelligent" charger with float charge functionality, the charger can be connected to the battery and switched on over the entire lay-up time.

Discharging

The closed-circuit current (power consumption in standby) that some electrical appliances constantly consume discharges the living area battery.

An older battery no longer has the complete capacity available.

The higher the number of active electrical appliances, the faster the energy of the living area battery is consumed.



- ▷ Reset the battery after a total discharge.

Storage

Prior to storage, fully charge the battery system and disconnect it from the transformer/rectifier (switch off battery cut-off switch on the transformer/rectifier).

At the latest, check the charge status on the display of the living area battery after 6 months. When the battery cut-off switch is switched off, the charging condition of the living area battery can drop to approx. 40 to 80 %. To check the charging condition, switch on the battery cut-off switch on the transformer/rectifier. Charge battery if necessary.

In case of a longer storage period: charge and discharge the living area battery several times if necessary to obtain full performance of the battery system.

Store the battery system in a place that is dry, cool, and well ventilated.

Observe the recommended storage temperature between 10 and 20 °C.

Take any further details on the storage temperature from the manufacturer's instruction manual.

Battery change



- ▷ When changing batteries, use only batteries which meet the minimum capacity of the charger. Observe the separate instruction manual for the charger. Lower-capacity batteries will generate a great deal of heat when they are charged. Danger of explosion!

When the living area battery is changed, only use batteries of the same type and the same capacity. Living area batteries must have a capacity of at least 80 Ah.

Only use batteries for which there are charging characteristics available. After changing the battery the charging characteristics must be adjusted at the transformer/rectifier or at the auxiliary charging unit.

If the living area battery is replaced and the charging unit does not provide a charging current of at least 10 % of the rating of a new battery, install an auxiliary charging unit.

Example With a battery capacity of 80 Ah, the charging unit must supply at least 8 A charging current.



- ▷ Before disconnecting or connecting the terminals of the battery, switch off the vehicle engine as well as the 230 V and 12 V power supplies and all appliances. Danger of short circuit!
- ▷ If the starter battery or living area battery are disconnected, do not apply the ignition. There is a danger of short circuit from exposed cable ends.
- ▷ When changing, ensure that the batteries are properly installed. Install the batteries so that the positive terminal on one battery is lying next to the negative terminal of the other battery.
- ▷ When changing, ensure that the batteries are properly connected.

Changing the battery:

- Turn off the vehicle engine.
- Switch off all appliances.
- Switch off 230 V power supply.
- Switch off 12 V power supply.
- Disconnect the negative terminal.
- Disconnect the positive terminal.
- Remove the old battery.
- Insert the new battery in the correct position.
- Connect the positive terminal.
- Connect the negative terminal.
- Switch on 12 V power supply.
- Switch on 230 V power supply.
- Switch on consumers as required.



- ▷ After changing the battery, have the battery voltage indicators checked at an authorised specialist workshop / service centre.

8.3.4 Energy balance of the living area battery

The living area battery has a limited power supply only. For this reason, the electrical appliances should not be operated without a 230 V power supply for a longer period of time.

Below, the calculation of the maximum operating time of the currently available battery capacity is described.



- ▷ The example calculation refers to a new, optimally charged battery. The actual effective battery capacity depends on the current charging condition and the age of the battery. The current battery capacity can be determined by means of special indicator units.
- ▷ If there is a second living area battery, the available capacity doubles.
- ▷ All lamps are LED lamps with very low power consumption. Approximately 2 W of power consumption can be expected per LED lamp.
 - Record the daily requirement. Note the switching on times and the power output of the devices used (see table below).

Example: The heater (power consumption 12 W) runs for 3 hours every day.

- Convert the power data into the required capacity in accordance with the following formulas:

Power consumption [W] : 12.8 V = Current [A]

Current [A] x Operating time [h] = Capacity [Ah]

12 W : 12.8 V = 0.94 A

Example calculation with rounded value:

1 A x 3 h = 3 Ah

The table for a whole day could look like this:

Balance of energy consumption (example)

Appliance	Power consumption [W]	Current [A]	Operating time [h]	Capacity [Ah]
Submerged pump	55	4.2	0.1	0.4
Heater	12	0.9	3.0	2.7
Projector	90	7.0	1.5	10.5
Refrigerator	34.3	2.6	24.0	62.4
Lighting	107	8.3	1.0	8.3
Sleeping roof pump	320	25.0	0.2	5.0
Average daily requirement				89.3

- Calculate the maximum effective energy with the following formula or determine it with a special indicator unit:
Current capacity [Ah] : Deep discharge protection = Maximum effective energy [Ah]

Example: 4 lithium-ion batteries with usable capacity of 4 x 80 Ah = 320 Ah

- Calculate the maximum operating time in accordance with the following formula:
Max. effective energy [Ah] : Daily requirement [Ah] = Max. operating time (in days)

Example: 320 Ah : 81.6 Ah = 3.92

The current battery capacity would be sufficient for almost 4 days if the daily demand remained the same.

Maximum possible wattage

In 230 V operation, the vehicle has a limited amount of power available via the local power connection. The maximum power can be 6 A ~ 1380 W, 10 A ~ 2300 W or 16 A ~ 3680 W, depending on the safety cut-out (fuse) at the camping site.

Read the exact amperage of the fuse at the connection point or ask at the camping site reception.

If the maximum current is exceeded due to excessive power consumption of the connected electrical appliances in the vehicle, the fuse in the external connection of the camping site or in the vehicle will automatically trip. Typically, devices such as heat exchangers, kettles, hair dryers, air conditioning, heater or, in some cases, the internal battery charging system have a high power consumption and therefore consume a lot of electricity.

When using the connected devices, observe the maximum possible wattage. Refer to the respective operating instructions for the power consumption of the devices.

To prevent the fuse from tripping unintentionally, keep the total power of the connected devices in line with the camping site's current limit. Take into account the total power consumption of your appliances and ensure that it is within the limits specified by the camping site.

Alternatively, the following formula can be used to calculate the power:

Electrical power (P) = Voltage (U) x Amperage (I).

Example calculation with 10 A:

230 V x 10 A = 2300 W

Solar cells

The self-sufficient period can be extended to the solar cells if there is good sunlight.

The standard solar installation has three 115 W solar cells.



- ▷ For further information on the solar installation, refer to the manufacturer's documentation for the solar installation.

8.4 Transformer/rectifier (EBL 402)



- ▶ The unit contains parts that carry 230 V line voltage. Potentially fatal electric shock or fire hazard!
Do not carry out any maintenance or repair work on the unit. If the cable or housing is damaged, do not put the unit into operation and disconnect it from the mains supply. Do not allow liquid to enter the unit.
- ▶ Replace defective fuses only when the unit is de-energised.
- ▶ Only replace defective fuses when the cause of the defect is known and has been remedied.
- ▶ Never bypass or repair fuses.
- ▶ Only use original fuses with the values specified on the unit.
- ▶ Device components can get hot during operation. Do not touch.
- ▶ Do not cover the ventilation slots. Danger of overheating!
- ▶ Do not store any heat-sensitive objects close to the unit (e.g. temperature-sensitive clothes if the unit is installed in the wardrobe).
- ▶ Observe the safety instructions and information in the separate device manufacturer's instruction manual.



- ▷ An extended period of total discharge may cause irreparable damage to the living area battery. Therefore, fully charge the living area battery before and after a lay-up.
- ▷ The transformer/rectifier, 12 V appliances or connected devices can be damaged if the limit values of the 230 V mains voltage are exceeded. Therefore, remember that it is essential for a generator to remain within the mains power ratings.
- ▷ Do not connect the vehicle to a generator until the generator is in stable operation.
- ▷ When on car ferries, do not connect the transformer/rectifier to the mains voltage (a perfect mains voltage is not always guaranteed with the mains supply on car ferries).

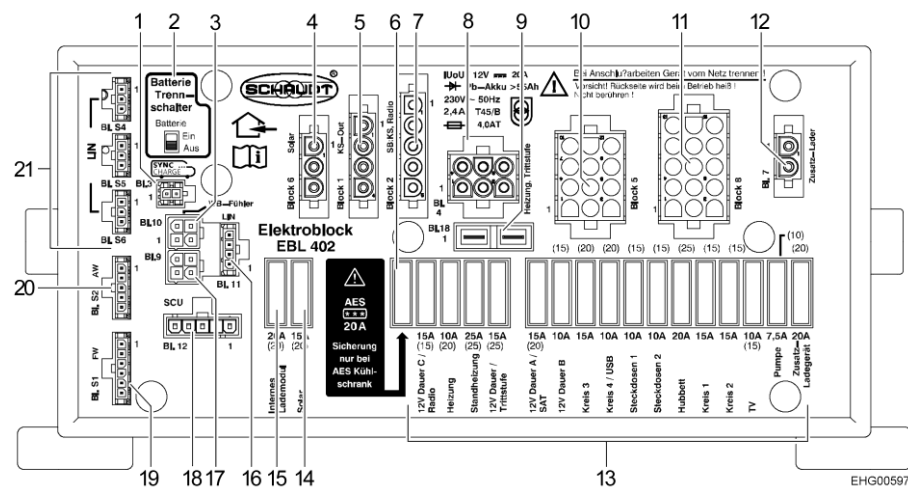



Fig. 100 Transformer/rectifier (EBL 402)

- 1 Block 3 SYNCCHARGE®
- 2 Battery cut-off switch ("Batterie Ein/Aus" (battery on/off))
- 3 Block 10 TSF01 (parallel to block 9)
- 4 Block 6 Solar charge regulator
- 5 Block 1 Refrigerator
- 6 AES 20 A fuse (only if vehicle is equipped with an AES refrigerator)
- 7 Block 2 Input D+, starter battery, refrigerator control
- 8 Block 4 Heater, Step
- 9 Block 18 Independent vehicle heater (not assigned)
- 10 Block 5 Power supply for 12 V appliances
- 11 Block 8 Power supply for 12 V appliances
- 12 Block 7 Auxiliary charging unit (not assigned)
- 13 Flat fuses (protection for the 12 V appliances)
- 14 Solar fuse (not assigned)
- 15 Fuse, Internal charger module
- 16 Block 11 LIN BUS
- 17 Block 9 TSF01 (parallel to block 10)
- 18 Block 12 (not used)
- 19 Block S1 Fresh water probe
- 20 Block S2 Waste water probe/sensors
- 21 Block S4, block S5, block S6 LIN BUS

Position The transformer/rectifier is installed under the bench on the driver's side (towards the kitchen) and is accessible by lifting the seat cushion.

- Operation** The transformer/rectifier is operated with the connected 7" operating panel (exception: battery cut-off for lay-up, see below).
 In normal operation, no operating steps are required on the transformer/rectifier.
 In following cases, adjustments are required:
- For initial commissioning.
 - When the battery type is changed.
 - When accessories are retrofitted.
- This adjustment work must be carried out by an authorised service centre.
- Purpose** Together with the control unit SCU and the bus modules, the transformer/rectifier EBL 402 forms the central control and power supply system for all 12 V appliances in the electrical system on board of the vehicle.
- Functions**
- The transformer/rectifier charges the living area battery. The transformer/rectifier charges the starter battery with a float charge only.
 - The transformer/rectifier monitors the voltage in the living area battery.
 - When the vehicle engine is turned off, the transformer/rectifier separates the starter battery electrically from the living area battery. This prevents the 12 V living area appliances from discharging the starter battery.
 - The transformer/rectifier controls and monitors connected solar charge regulators and auxiliary charging units.
 - The transformer/rectifier supplies all BUS modules and the connected sensors and appliances with current.
 - Via BUS lines, the transformer/rectifier provides the communication with the BUS modules, the panel will and the control unit SCU.
- The transformer/rectifier only works in conjunction with a BUS-capable panel.
 The power in the transformer/rectifier is divided into charging current and current to the appliances. The charging current is always just the portion that is not being used by any appliances. If the current to the appliances exceeds the current available, then the living area battery is discharged.
- Lay-up** Some circuits are still supplied with current even when the 12 V power supply is switched off on the panel. These are all appliances connected to the 12 V constant positive, for example:
- Entrance step
 - Heater
- When the vehicle is laid up, these appliances are also disconnected from the battery.
- Lay-up:*
- Switch off the 12 V power supply on the panel.
 - Move the battery cut-off switch (Fig. 100,2) to the "Aus" (Off) position on the transformer/rectifier EBL 402.
-  ▷ When the battery cut-off switch is switched off, the central locking system only opens the driver's door or, depending on the vehicle, also the passenger's door. If the vehicle is laid up, the living area door must be unlocked manually using the mechanical key (see section 6.1).

- Coming out of lay-up:
- Move the battery cut-off switch (Fig. 100,2) to the "Ein" (On) position on the transformer/rectifier EBL 402.
 - Switch on the 12 V power supply on the panel.



- ▷ Further information can be obtained in the manufacturer's instruction manual.

8.5 7" panel

The 7" panel with touch display is part of the vehicle's bus system. (Other components of the bus system are the transformer/rectifier EBL 402, the system control SCU and the HYMER Connect app.)

The vehicle's operating functions can be displayed, monitored and controlled on the 7" panel. In addition, various functions can be combined and saved as scenarios. Private information can also be included.

The 7" panel can be connected to the HYMER Connect app.

Position The 7" panel is installed in the area of the access stairs.

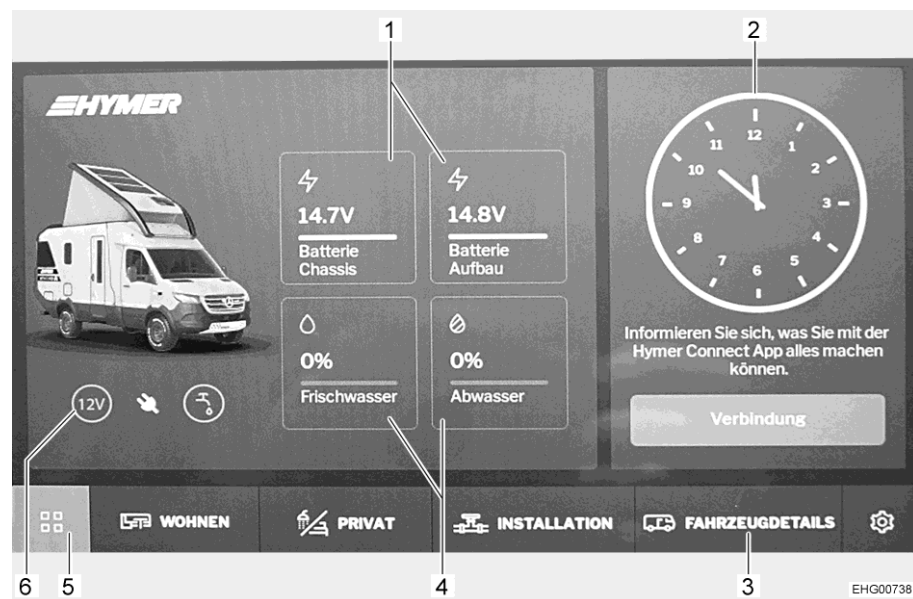

Fig. 101 7" panel, start screen

- | | |
|-------------------------------|-------------------------------|
| 1 Batteries voltage indicator | 4 Water tanks level indicator |
| 2 Time | 5 Switching on/off |
| 3 Main menu navigation bar | 6 Selection switch field |

The 7" panel displays the following data:

- 12 V On/Off
- 230 V indicator
- Water pump on/off indicator (only when 12 V on)
- Starter battery indicator
- Living area battery indicator with lithium bat. in % (for AGM battery in volts)
- Settings
- Menu bar



- ▷ After a longer absence, it can take up to 2 minutes until the display shows current data (see energy-saving mode).
- ▷ If the display fails, emergency operation of the SCU is possible (see section 8.5.1)

The following functions can be activated in the selection switch field (Fig. 101,6):

- Switching on the 12 V power supply
- Displaying the status of the 230 V power supply
- Switch water pump on

The following main menus can be called up via the navigation bar (Fig. 101,3):

- COMMUNAL
- PERSONAL
- INSTALLATION
- VEHICLE DETAILS

Clicking a button opens the respective sub menu.

8.5.1 System Control Unit (SCU)



- ▷ FAQs on the operation of the SCU and the HYMER Connect app can be found under the following link:
<https://www.hymer.com/de/en/connect-app>
 The FAQs are constantly being expanded.

The SCU takes over central control and monitoring functions in the vehicle. The control and monitoring functions are operated on the 7" panel or via the HYMER Connect app. On the SCU itself, operation is limited to initiating the connection process (pairing).

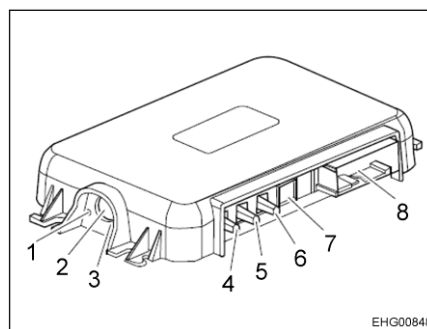

- 1 LED indicator (green)
- 2 Pairing button to connect with Bluetooth-enabled device
- 3 LED indicator (blue)
- 4 Bluetooth antenna connection (curry)
- 5 GPS antenna connection (blue)
- 6 LTE antenna connection (bordeaux)
- 7 Diagnostics connection
- 8 Vehicle communication connection

Fig. 102 System Control Unit

Emergency operation

During emergency operation of the vehicle, the display of the SCU is without function.

Functions in emergency operation:

- 12 V power supply
- Lamps via light switches
- Water pump active



- ▷ In emergency operation, battery and water levels **cannot** be called up.

Requirements for emergency operation:

- No external power supply connected
- Engine switched off
- All water taps closed



- ▷ Before activating the emergency operation, make sure that all water taps in the vehicle are closed.

If not all water taps are closed, the pump can run dry and water can escape uncontrollably. Property damage may occur.

Activating the emergency operation:

- Gain access to the transformer/rectifier.
- Switch the battery cut-off switch ("Batterie Ein/Aus" (Battery On/Off)) off and on again four times in succession.
- Leave the battery cut-off switch in the "Ein" (On) position.



- ▷ If the SCU fails or is defective, contact an authorised dealer.

Energy-saving mode

The SCU will automatically enter energy-saving mode after 48 hours if no user is connected to the SCU and the vehicle is not connected to an external power supply.

The energy-saving mode is ended by the following actions, for example, and the SCU then returns to "Active operation":

- Unlocking/locking the vehicle (depending on the vehicle type)
- Activating the ignition of the vehicle
- Touching the display
- Starting the HYMER Connect app on a mobile device connected to the SCU

Position

The SCU is installed underneath the floor trap behind the driver's / front passenger's seat.

8.5.2 HYMER Connect App

Mobile devices can be connected to the vehicle via the HYMER Connect app.

Requirements for connecting the mobile device to the SCU:

- Completed installation of the HYMER Connect app on a mobile device
- Vehicle QR code
- Compatible vehicle equipped with a SCU

For each vehicle equipped with a SCU, a main user can connect to the SCU via their mobile device (using the HYMER Connect app and the vehicle QR code). This main user can create guest accesses for other mobile devices via the HYMER Connect app and also manage them there.



- ▷ The HYMER Connect app is available free of charge in the Apple App Store (iOS) and the Google Play Store (Android).
- ▷ If the vehicle QR code has been lost, contact the manufacturer's customer service or an authorised dealer.

To connect the mobile device to the vehicle, follow the instructions in the HYMER Connect app. If a main user is already connected to the SCU (message appears during pairing), the previous owner must first delete his connection.

If this is not possible, the customer service can delete the connection of the previous main user by presenting the proof of ownership.

8.5.3 Bluetooth connection



- ▷ Bluetooth is a registered trademark of the Bluetooth SIG, Inc.

If the HYMER Connect app is installed on a mobile device (smartphone or tablet computer), various vehicle functions can be operated from the mobile device. In order to do this, the mobile device must be paired with the vehicle's System Control Unit (SCU) via Bluetooth. This process is called "pairing". The pairing is only required once for each mobile device.

Pairing a mobile device:

- Open the floor plate between the secretary and the access stairs.
- Scan the QR code and press the pairing button (Fig. 102,2) on the SCU. The QR code is printed in a separate document that is delivered with the vehicle documents.



- ▷ Alternatively, the pairing process can also be triggered via the 7" panel.

The download and installation process of the HYMER Connect app is started automatically. The mobile device is then paired with the SCU. The vehicle now appears on the mobile device in the list of paired Bluetooth devices.

8.6 AC converter (Victron) with integrated charger



- ▷ Check the FI switch for each connection to the 230 V power supply, at least once every 6 months.
- ▷ If the vehicle is not connected to the 230 V power supply and no electricity is required, switch off the AC converter. Even in idle state, the AC converter still uses power from the living area battery.
- ▷ The AC converter is equipped with a 230 V priority circuit. If an external 230 V voltage is connected, it will be used primarily. Only if no external 230 V voltage is connected, the living area battery will be used for voltage supply.
- ▷ If not external 230 V power supply is connected, the AC converter draws energy from the living area battery. The living area battery has a limited power supply only. For this reason, the electrical appliances should not be operated from the electrical sockets for long periods without using the 230 V connection.
- ▷ To protect the living area battery against total discharge, the AC converter automatically switches itself off if there is undervoltage. The AC converter automatically switches itself on again when the voltage is back up to the standard value.



- ▷ In the event of overload or insufficient cooling, the AC converter switches itself off automatically. The AC converter automatically switches itself back on when there is no longer an overload and the temperature of the device is down to a safe level.
- ▷ If the appliance fuse has triggered, it must be pushed in again manually.
- ▷ Take and observe further instructions and information from the separate manufacturer's instruction manual.



- ▷ The AC converter must be set to the "ON" position, otherwise the priority circuit will not work and therefore no 230 V will be available at the sockets.

Functions

The AC converter has the following functions:

If no external 230 V power supply is connected, the AC converter generates a 230 V voltage for all sockets in the vehicle out of the 12 V DC voltage of the living area battery.

If an external 230 V power supply is connected, this will be used to supply the sockets. In this case, the AC converter will not draw power from the living area battery.

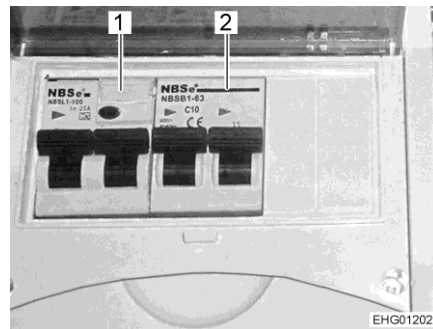

- 1 FI switch for sockets
- 2 Safety cut-out for sockets

Fig. 103 AC converter fuse box

The sockets are protected by a safety cut-out (Fig. 103,2) and a FI switch (Fig. 103,1) in the AC converter fuse box.

Installation positions

The AC converter is installed in the underfloor trough on the driver's side and is accessible from outside. The switch for the AC converter is either installed in the secretary or provided as a button on the 7" panel.

The AC converter fuse box is installed underneath the kitchenette together with the local power fuse box. To access the fuse boxes, the two lower drawers can be pulled out, unlocked by lifting them slightly and removed.

Voltage-free state

To completely de-energise the electrical system, the FI switches in both the AC converter fuse box and the local power fuse box must be deactivated.



- ▷ Take any further information from the manufacturer's instruction manual.

8.7 230 V power supply



- ▶ Only allow qualified personnel to work on the electrical system.
- ▶ Have the vehicle's electrical system checked by a qualified electrician at least once every 3 years. If the vehicle is used frequently, an annual check is recommended.

The 230 V power supply provides electricity for the following devices (if present):

- Sockets with earth contact for appliances with maximum 10 A
- Refrigerator
- Transformer/rectifier
- Auxiliary charging unit
- Air conditioning unit

The electrical appliances connected to the 12 V power supply of the living area are supplied with voltage by the living area battery.

Connect the vehicle to an external 230 V power supply system as often as possible. The charger module in the transformer/rectifier automatically charges the living area battery. In addition to this, the starter battery is charged with a float charge of 2 A.

Depending on the equipment, optional devices are fuse-protected by their own two-pole automatic circuit breaker.

8.7.1 230 V connection (CEE socket outlet)



- ▷ Overvoltage can damage connected devices. Overvoltage can be caused by lightning, irregular voltage sources (e.g. petrol-operated generators) or power connections on ferries for example.

Requirements concerning the 230 V connection

- The connecting cable, the plug connectors at the point of supply and the plug connector to the vehicle must comply with IEC 60309. The standard designation for the plug connectors is "CEE blue".
- Use H07RN-F rubber sheathed cable with a minimum cable cross-section of 2.5 mm² and a maximum length of 25 m.
- Earth contact connectors (safety) are not permitted. The interconnection of CEE/safety adapters is also prohibited.

8.7.2 Connecting the 230 V power supply



- ▶ The external 230 V power supply must be protected by fuse with a fault current protection switch (FI switch, 30 mA).
- ▶ To prevent overheating, the cable must be fully uncoiled from the cable reel.
- ▶ In case of doubt or if the 230 V supply is not available or is faulty, contact the operator of the power supply device.



- ▷ The 230 V connection in the vehicle is equipped with a FI switch.
- ▷ For the connection points on camp sites (camping distributors) FI switches, (30 mA) are obligatory.

The vehicle can be connected to an external 230 V power supply. As a principle, only use the 230 V connection on the vehicle (CEE socket outlet) for connecting.

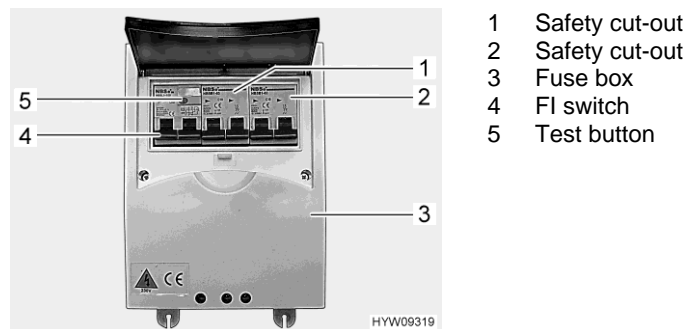

Fig. 104 Safety cut-out and FI switch
(230 V fuse box)



Connecting the vehicle:

- ▷ The second safety cut-out (Fig. 104,2) is optional. Whether this safety cut-out is present or not depends on the equipment of the vehicle.
 - Check whether the power supply device is suitable regarding connection, voltage, frequency and current.
 - Check whether the cables and connections are suitable.
 - Check the plug connectors and cables for visible damage.
 - Switch off both safety cut-outs (Fig. 104,1 and Fig. 104,2) in the fuse box (Fig. 104,3).



Fig. 105 230 V connection on the vehicle (CEE socket outlet)

- Open the cover of the 230 V connection on the vehicle (Fig. 105) and insert the plug connector. Ensure that the detent of the spring-mounted pivoting cover is engaged in position.
- Plug the connector of the connecting cable into the socket of the camping distributor. Ensure that the detent of the spring-mounted flap is also engaged here.
- Switch on both safety cut-outs in the fuse box.

Checking the FI switch:

- When the vehicle is connected to the 230 V supply, press the test button (Fig. 104,5) of the FI switch (Fig. 104,4) in the fuse box (Fig. 104,3). The FI switch must trip.
- Switch the FI switch (Fig. 104,4) back on again.

Unplugging the connection:

- Switch off both safety cut-outs (Fig. 104,1 and 2) in the fuse box (Fig. 104,3).
- Loosen the detent on the camping distributor and unplug the connecting cable from the socket.
- Loosen the detent on the vehicle unplug the plug connector and close the cover of the 230 V connection.

8.8 Solar installation

Information on the solar installation is displayed on the 7" panel (see section 8.5).

Switching on/off

The solar installation is not switched manually. As soon as solar radiation is present, the solar regulator charges the living area battery. The display panel is supplied with power by the solar regulator.

Operation

Information on the solar installation is displayed on the 7" panel in the main menu "INSTALLATION" (see section 8.5).

8.9 Fuses



- ▶ Only replace defective fuses when the cause of the defect is known and has been remedied.
- ▶ Replace defective fuses only after the power supply has been turned off.
- ▶ Do not replace screwed fuses yourself. Contact an authorised specialist workshop to have these replaced.
- ▶ Never bridge or repair fuses.
- ▶ Only replace faulty fuses with a new fuse with the same rating.

8.9.1 12 V fuses

The appliances connected to the 12 V power supply in the living area are fused individually. The fuses are accessible at different positions in the vehicle.

Before changing fuses, take the function, value and colour of the relevant fuses from the following specifications. When changing fuses, only use flat fuses with the values shown below.

Some signals are protected by "Polyswitch" fuses. Polyswitch is an internal self-resetting fuse. After the overcurrent or short circuit has been remedied, the operating current is enabled again automatically. This can take a few seconds (cooling-down phase).

Fuses for the driver's area

The fuses are installed behind a cover (Fig. 106) in the console of the driver's seat.



Fig. 106 Cover (driver's seat)

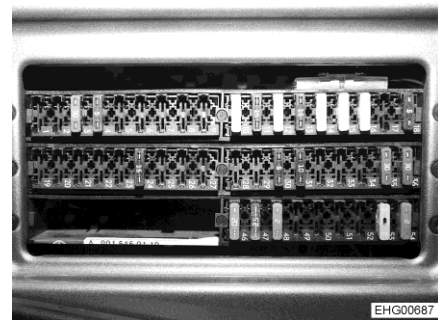

Fig. 107 Fuses (driver's seat)

8.9.2 Values of the 12 V fuses

Fuses in the underbody electrical installation compartment (floor trap behind the driver's / front passenger's seat) underneath black cover		
Number	Appliances	Value
4	Lithium battery	80 A
1	AC converter	175 A
1	Solar installation	30 A
1	Compressor for roof pneumatics	30 A
1	Charge booster	80 A
1	Transformer/rectifier	50 A
1	Appliances	175 A

Fuses on the transformer/rectifier (under the seating group, rear left)				
Number	Appliances	Type of fuse	Value	Colour
1	Internal charger module	Flat fuse	25 A	Transparent
1	Solar installation	Flat fuse	15 A	Blue
1	12 V permanent C / radio	Flat fuse	15 A	Blue
1	Heater	Flat fuse	20 A	Yellow
1	Independent vehicle heater	Flat fuse	25 A	Transparent
1	12 V permanent / step	Flat fuse	15 A	Blue
1	12 V permanent A	Flat fuse	15 A	Blue
1	12 V permanent B	Flat fuse	10 A	Red
1	Circuit 3	Flat fuse	15 A	Blue
1	Circuit 4 / USB	Flat fuse	10 A	Red
1	Sockets 1	Flat fuse	10 A	Red
1	Sockets 2	Flat fuse	10 A	Red
1	Pull-down bed	Flat fuse	20 A	Yellow
1	Circuit 1	Flat fuse	15 A	Blue
1	Circuit 2	Flat fuse	15 A	Blue
1	TV	Flat fuse	10 A	Red
1	Water pump	Flat fuse	7.5 A	Brown
1	Auxiliary charging unit	Flat fuse	20 A	Yellow

Other fuses				
Number	Appliances	Type of fuse	Value	Position
1	Thetford toilet	Polyswitch, maintenance-free, self-resetting		Toilet
All LED strips	LED strip (e.g. plinth lighting)	Polyswitch, maintenance-free, self-resetting		In front of LED strip

8.9.3 230 V fuse



- ▶ If, when the AC converter is switched on, the 230 V connection is disconnected or the 230 V main fuse is switched off, this will not activate the sockets since these are supplied by the AC converter.
- ▶ The safety cut-out in the additional fuse box for the AC converter secures and breaks the circuit only for the sockets in the vehicle.
- ▶ Only by switching off both fuse boxes and the AC converter is the mains power supply fully activated.



- ▷ Check the FI switch for each connection to the 230 V power supply, at least once every 6 months.

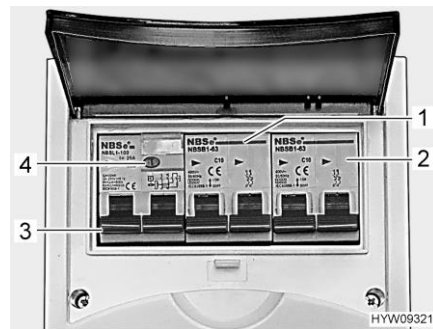

- 1 Safety cut-out (10 A)
- 2 Safety cut-out (16 A)
- 3 Fault current protection switch (FI switch)
- 4 Test button

Fig. 108 Safety cut-out and FI switch (230 V fuse box)

A FI switch (Fig. 108,3) in the fuse box protects the complete vehicle from fault current (30 mA).

The downstream safety cut-out (10 A) (Fig. 108,1) secures the 230 V sockets, the transformer/rectifier and the auxiliary charging unit.

For vehicles with optional equipment, e.g. roof air conditioning unit, the device is protected by an additional safety cut-out (16 A) (Fig. 108,2).

Checking the FI switch:

- When the vehicle is connected to the 230 V power supply, press the test button (Fig. 108,4). The FI switch must trip.

Position

The fuse box is installed underneath the kitchenette and accessible via a drawer.

Chapter overview

This chapter contains instructions regarding the appliances of the vehicle. The instructions refer exclusively to the operation of the appliances. Further information about the appliances can be found in the instruction manuals for the appliances, included separately with the vehicle.

9.1 General



- ▷ For safety reasons, spare parts for pieces of heating appliances must correspond with manufacturer's instructions and be permitted by the manufacturer as a spare part. These spare parts may only be fitted by the manufacturer or an authorised specialist workshop.



- ▷ Further information can be obtained in the instruction manual for the respective appliance.

The heater, boiler, cooker and refrigerator are fitted depending on the model of the vehicle.

In this instruction manual a description is given only for the operation of the appliances and their particular features.

Before using the cooker, open the regulator tap on the gas bottle and the gas isolator tap on the cooker (underneath the sink).

9.2 Heater and boiler

The heater can both heat up the vehicle interior (heating the room air) and heat up the domestic water (boiler function). The following instructions are also valid if the heater is only used as boiler.



- ▶ Never operate the heater in diesel operation when refuelling, on ferries or in the garage. Danger of explosion!
- ▶ Never operate the heater in diesel operation in closed spaces (e.g. garages). Danger of poisoning and suffocation!
- ▶ The waste gas vent may neither be closed nor blocked.
- ▶ Do not use the space behind the heater as a storage space.
- ▶ The water in the boiler can be heated up to 65 °C. Risk of scalding!



- ▷ Never use boiler when empty.
- ▷ If the boiler is not being used, empty it if there is any risk of frost.
- ▷ Only operate the boiler with the maximum temperature setting if you require a large quantity of warm water. This protects the boiler against the build-up of limescale.



- ▷ Do not use the water from the boiler as drinking water.
- ▷ If the power supply to the heater was interrupted, the time must be reset.

Initial start-up When lighting the heater for the first time a small amount of smoke and odour will occur. Immediately set the operating switch of the heater to its highest position. Open doors and windows and ventilate well. Smoke and odour will disappear by themselves after a while.

9.2.1 Heating properly



- ▷ The air outlet nozzles must always remain unobstructed and must not be blocked or obstructed in order to allow a free air current and to avoid heat build-up.
- ▷ Objects placed in front of the air outlet nozzles can be damaged by the heat build-up.
- ▷ If the air current is persistently blocked, the heat build-up can cause damage to the vehicle.



Fig. 109 Air outlet nozzle (hot-air heater)

Hot air distribution Several air outlet nozzles (Fig. 109) are installed in the vehicle directing warm air from the heater into the living area. Turn the air outlet air outlet nozzle in a suitable position so the air can escape as required.

When the vehicle's air outlet nozzles on the dashboard are in the open position during heating, the heating air circulates and escapes. To prevent this, close the air outlet nozzles on the dashboard and set the base vehicle's air distribution to air circulation.

Adjusting the air outlet nozzle

- Fully open: full hot air stream
- Half or partially open: reduced hot air stream

When all air outlet nozzles are fully open, less warm air comes out of each nozzle. However, when only some of the air outlet nozzles are open, more warm air will flow out of each nozzle.

9.2.2 Hot-air heater and boiler with digital CP plus control unit



- ▶ If leakage occurs at the heater or at the exhaust gas routing, there is a risk of poisoning! If leakage is detected: switch off the diesel hot-air heater. Open windows and doors. Have the system checked by an authorised service centre.
- ▶ Observe the safety regulations and safety instructions of the manufacturer; see separate instruction manual of the manufacturer.



- ▷ If there is a risk of frost and the heater is not in operation, empty the boiler.
- ▷ The circulation fan is automatically switched on when the hot-air heater is activated, and it stays on. This puts an immense strain on the living area battery, if the vehicle is not connected to an external 230 V power supply. Take into consideration that the living area battery only has limited reserves of energy.



- ▷ The hot-air heater can even run on an empty boiler.
- ▷ If the power supply to the heater was interrupted, the time must be reset.

Maximum heat output

Diesel operation	Electrical operation *	Mixed operation (diesel and electrical operation)*
6000 W	1800 W	6900 W

* (Optional)

Control unit

The control unit is divided into two sections:

- Display
- Operating buttons



- 1 Display
- 2 Rotary push button
- 3 Back button

Fig. 110 Control unit (hot-air heater and boiler)

Position

The control unit is installed in the secretary to the right of the living area door.

Operating buttons

The operating buttons have the following functions:

Button	Button operation	Function
Rotary push button (Fig. 110,2)	Turn to the right	Menu is run through from left to right Values are increased
	Turn to the left	Menu is run through from right to left Values are decreased
	Press briefly	Selected value is saved Menu item is selected for changing values (selected menu item flashes)
	Press (3 seconds)	Switch on or switch off
Back button (Fig. 110,3)	Press	Return from a menu item without saving values

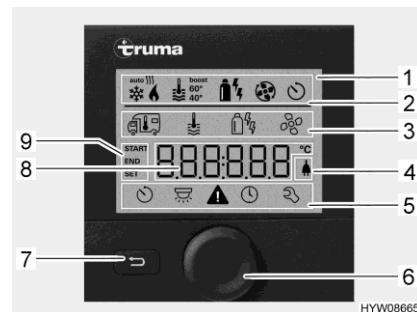

- 1 Display
- 2 Status line
- 3 Upper menu line
- 4 Display line voltage 230 V
- 5 Lower menu line
- 6 Rotary push button
- 7 Back button
- 8 Settings and values display area
- 9 Timer display

Fig. 111 Control unit with display

Display

The display is divided into four sections:

- Status line (Fig. 111,2)
- Upper menu line (Fig. 111,3)
- Display area (Fig. 111,8)
- Lower menu line (Fig. 111,5)



- ▷ The heater can be controlled either via the 7" panel or the control unit (Fig. 110 and Fig. 111), but not simultaneously via both operating controls.
- ▷ Before operating the heater using the control unit, exit the corresponding menu on the 7" panel or switch off the 7" panel.

Switching the control unit on/off

After being switched on, the most recently set values/operating parameters are activated.

If no button is pressed, the control unit switches to stand-by mode after a few minutes.

If the time is set, the display in stand-by mode alternates between the time and the room temperature set.

After being switched off, the display in the control unit may remain active for several minutes since the heater is still running.

- Press and hold the rotary push button (Fig. 111,6) for approx. 3 seconds. Both menu lines (Fig. 111,3 and Fig. 111,5) are displayed. The first symbol flashes.



- ▷ Switching the control unit on/off means switching between stand-by and setting mode. In stand-by mode, the display alternates between the room temperature and the time that have been set.

Carrying out settings:

- Turn the rotary push button (Fig. 111,6) until the required menu symbol flashes.
- Press the rotary push button.
- Turn the rotary push button until the required value is displayed.
- Press the rotary push button to save the value set. If you do not wish to change the value originally set: Press the back button (Fig. 111,7).

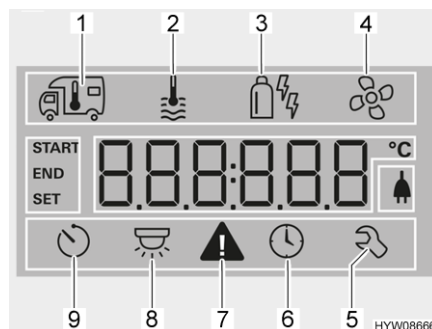

- 1 Heater
- 2 Hot water
- 3 Operating mode
- 4 Fan
- 5 Service menu
- 6 Setting the time
- 7 Warning symbol
- 8 Lighting (not used here)
- 9 Timer

Fig. 112 Display (control unit)

Switching on the heater:

- Turn rotary push button (Fig. 111,6) until the heater menu symbol (Fig. 112,1) flashes.
- Press the rotary push button.
- Turn the rotary push button until required value is displayed.
- Press the rotary push button to save the value set. The symbol in the status line (Fig. 111,2) flashes until the room temperature set is reached. If you do not wish to change the value originally set: Press the back button (Fig. 111,7).

Switching off the heater:

- Turn the temperature value back until OFF is displayed. Press the rotary push button to save.



- ▷ The required room temperature can also be changed in stand-by mode by turning the rotary push button.

Switching on production of hot water:

- Turn the rotary push button (Fig. 111,6) until the hot water menu symbol (Fig. 112,2) flashes.
- Press the rotary push button.
- Turn the rotary push button until the required value is displayed:
 - OFF: Production of hot water is switched off.
 - 40°: Hot water is heated to 40 °C.
 - 60°: Hot water is heated to 60 °C.
 - BOOST: Fast heating of hot water (boiler priority) for max. 40 minutes. The water temperature is then held at a higher level for two reheating cycles (approximately 62 °C).

- Press the rotary push button to save the value set. The symbol in the status line (Fig. 111,2) flashes until the hot water temperature set is reached. If you do not wish to change the value originally set: Press the back button (Fig. 111,7).

Switching off production of hot water:

- Turn the rotary push button until OFF is displayed. Press the rotary push button to save.

Safety/drainage valve

The boiler is equipped with a safety/drainage valve (Fig. 113). The safety/drainage valve prevents water in the boiler from freezing, when there is frost and the heater is not switched on.



- ▷ When the vehicle is not used for a long period of time, open the safety/drainage valve and empty the boiler.
- ▷ At temperatures below 3 °C the safety/drainage valve opens automatically. Only if the temperature of the safety/drainage valve lies above 7 °C can it be shut again.
- ▷ The water pump and the water fittings are not protected against freezing by the safety-/drainage valve.



- ▷ The drainage neck of the safety/drainage valve has to be free of dirt (e.g. leaves, ice) at all times.

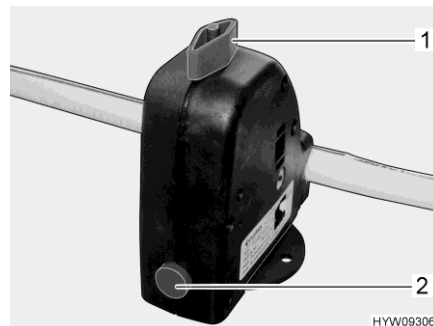

- 1 Knob
- 2 Push button

Fig. 113 Safety/drainage valve (boiler)

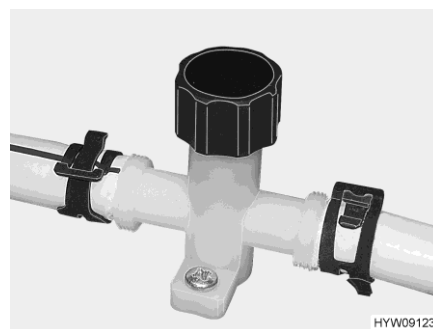

Fig. 114 Drain cock (water pipe)

Position

The safety/drainage valve is installed underneath the cover of the first step to the sleeping roof.

Filling/emptying the boiler

The boiler can be supplied with water from the water tank.

Filling the boiler with water:

- Switch on the 12 V power supply on the panel.
- Close the safety/drainage valve. Turn the knob (Fig. 113,1) perpendicular to the safety/drainage valve and push the push button (Fig. 113,2) in.
- Set all the water taps to "Hot" and open them. The water pump is turned on. The warm water pipes are filled with water.
- Keep the water taps open until the water flowing out of the water taps has no bubbles in it. This is the only way to ensure that the boiler is full of water.
- Close all water taps.





Emptying the boiler:

- Switch off hot water production.
- Open the safety/drainage valve. To do this turn the knob (Fig. 113,1) parallel to the safety/drainage valve. The push button (Fig. 113,2) jumps out. The boiler is drained to the outside by the safety/drainage valve.
- Check whether the water has been drained completely from the boiler (approx. 10 litres).
- Close the drain cocks. In order to do this, turn the cap of the drain cock (Fig. 114) in a clockwise direction.

Operating modes

Depending on the equipment, the hot-water heater with the boiler can be operated by means of various energy sources.

Selecting operating mode:

- Turn rotary push button (Fig. 111,6) until the menu symbol operating mode (Fig. 112,3) flashes.
 - Press the rotary push button.
 - Turn rotary push button until the desired operating mode is displayed:
 -  Diesel operation
 -  Electrical operation, output level 1 (900 W) *
 -  Electrical operation, output level 2 (1800 W) *
 -  Diesel operation and electrical operation, output level 1 (900 W) *
 -  Diesel operation and electrical operation, output level 2 (1800 W) *
- * (optional)
- Press the rotary push button to save the set operating mode. To revert to the original setting: Press the back button (Fig. 111,7).



- ▷ 230 V electrical operation is only possible when the vehicle is connected to the 230 V power supply.
- ▷ At output level 1 (900 W), current consumption is 3.9 A. At output level 2 (1800 W), current consumption is 7.8 A.

- Setting the fan:*
- Turn rotary push button (Fig. 111,6) until the fan menu symbol (Fig. 112,4) flashes.
 - Press the rotary push button.
 - Turn the rotary push button until the required value is displayed:
 - OFF: Fan is switched off.
 - VENT: Air circulation
 - ECO: Low fan setting
 - HIGH: High fan setting
 - BOOST: Fast room heating. Boost is available if the current room temperature is at least 10 °C below the selected room temperature.
 - Press the rotary push button to save the value set. If you do not wish to change the value originally set: Press the back button (Fig. 111,7).

- Setting the timer:*
- Turn rotary push button (Fig. 111,6) until the timer menu symbol (Fig. 112,9) flashes.
 - Press the rotary push button. The start time is displayed and the hour display flashes.
 - Turn rotary push button until the hour of the selected start time is displayed.
 - Press the rotary push button. The minute display flashes.
 - Turn rotary push button until the minute of the selected start time is displayed.
 - Press the rotary push button.
 - Proceed in the same way to set the switch-off time, the required room temperature, the hot water setting and the fan setting.
 - Press the rotary push button. The timer is activated. The timer symbol (Fig. 112,9) flashes when the timer is programmed and active.



- ▷ The service menu contains items that generally only need to be set once (language, background brightness, calibration), as well as information for service centres (version numbers).

Fault display

The warning symbol (Fig. 112,7) flashes in the event of a warning. The heater continues to operate. In the event of only a temporary fault, the warning symbol goes out automatically.

In the event of a warning, the control unit displays the error code for the fault. The heater is switched off. Press the rotary push button to restart the heater.



- ▷ Further information can be obtained in the manufacturer's instruction manual.



Fig. 115 Sliding regulator for hot air distribution in the sleeping roof

**Hot air distribution
Sleeping roof**

The hot air flow from the heater can also be directed into the sleeping area in the sleeping roof as required. For this purpose, a sliding regulator has been built into one of the steps of the access stairs.

For any further information see section 5.9.

9.2.3 Wall flue

Fresh air and exhaust gases of the heater system are conducted in a two-chamber wall flue.



- ▷ Park the vehicle such that the wall flue gets enough fresh air.
- ▷ The wall flue must be free at all times. Do not cover the wall flue.
- ▷ When camping in winter, maintain wall flue free of snow and ice.
- ▷ Check the wall flue periodically depending on the weather (snow, leaf fall, dirt, etc.). If necessary, clean the wall flue.
- ▷ When washing the vehicle do not aim the water jet directly at the wall flue.
- ▷ When disregarding this, the flawless operation of the heater can not be guaranteed.



Fig. 116 Wall flue (hot-air heater)

The wall flue is mounted on the left side wall.

9.2.4 Independent vehicle heater



- ▷ The optional independent vehicle heater is part of the base vehicle. Read the instruction manual for the base vehicle.

9.3 Air conditioning unit Truma Saphir (optional)



- ▷ The cooling circuit may only be opened by the manufacturer.
- ▷ Do not block the air inlets and air outlets. When installing in the storage compartment, ensure that the free space in front of the air outlets is not blocked.
- ▷ Do not drive on any gradients or inclines greater than 8 % when the air conditioning unit is in operation. Otherwise the appliance may be damaged.
- ▷ Do not operate the unit in cooling mode for extended periods when the vehicle is on an incline. Otherwise, condensation water cannot drain off and may get into the interior.



- ▷ The air conditioning unit only runs when the vehicle is connected to a 230 V power supply.
- ▷ The external 230 V power supply must be protected by a fuse of at least 3 A. It is otherwise not possible to operate the air conditioning unit properly.
- ▷ Always point the remote control at the infrared receiver when using it.
- ▷ Depending on the equipment, the air conditioning unit can be operated from a mobile terminal (e.g. smartphone, tablet PC) via an app. The Truma app can be loaded for common mobile terminals via the respective app stores.
- ▷ Also read the manufacturer's instruction manual.

Position The air conditioning unit is installed in a storage compartment on the left side of the vehicle.

Operating modes The air conditioning unit can be operated in the following modes:

- Cooling
- Air circulation

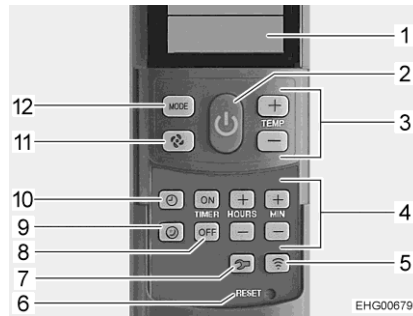

Fig. 117 Remote control (air conditioning unit)

- 1 Display
- 2 On/Off button
- 3 "+" and "-" buttons (temperature selection)
- 4 "+" and "-" buttons (time and timer)
- 5 Send button (repeat data transfer)
- 6 Micro button "RESET" (resetting to the factory setting)
- 7 Setup button
- 8 "OFF" button
- 9 Soft-start button
- 10 Time button
- 11 Fan button
- 12 "MODE" button

Operation

All functions of the air conditioning unit can be operated via the remote control.

Switching on:

- Press the On/Off button (Fig. 117,2). The last settings selected are accepted.



- ▷ The circulation fan runs after switching on. The compressor switches on after 3 minutes at the latest, the green LED (cooling) is flashing.

Switching on the cooling:

- Press the "MODE" button" (Fig. 117,12) until the cooling symbol appears in the display (Fig. 117,1).
- Use the "+" and "-" buttons (Fig. 117,3) to set the desired temperature.
- Use the fan button "🌀" (Fig. 117,11) to set the desired fan setting (low / medium / high).

When the room temperature set on the remote control is reached, the compressor switches off and the green LED in the infrared receiver goes out. The circulation fan continues to run.

When the room temperature rises above the set temperature, the unit automatically switches itself back to cooling mode.

Switching on air circulation:

- Press the "MODE" button (Fig. 117,12) until the air circulation symbol appears in the display (Fig. 117,1).
- Use the fan button "🌀" (Fig. 117,11) to set the desired fan setting (low / medium / high).

In air circulation mode, the inside air is circulated and is cleaned by the filter. No LEDs are lit on the infrared receiver.

Activating soft-start:

- Press the soft-start button (Fig. 117,9). The fan then runs at low speed in cooling mode, which makes it especially quiet.

Switching off:

- Press the On/Off button (Fig. 117,2). The remote control and air conditioning unit are switched off.

Setting the time:

- Press the time button (Fig. 117,10). The time is flashing.
- Use the "+" and "-" buttons (Fig. 117,4) to set the hours ("HOURS") and minutes ("MIN").

Timer With the integrated timer, the switch-off time for the air conditioning unit can be set between 15 minutes and 24 hours in advance (calculated from the current time).

- Switching on the timer:*
- Press the On/Off button (Fig. 117,2).
 - Set the desired mode and temperature.

- Programming the switch-off time:*
- Press "OFF" button (Fig. 117,8).
 - Use the "+" and "-" buttons (Fig. 117,4) to set the desired switch-off time.
 - To confirm, press the "OFF" button (Fig. 117,8) again.

- Switching off the timer:*
- Press "OFF" button (Fig. 117,8).



- ▷ The setup button (Fig. 117,7) is used to connect the remote control with the air conditioning unit during first set-up.



- 1 Red LED
- 2 Pushbutton
- 3 Green LED

Fig. 118 Infrared receiver (air conditioning unit)

Infrared receiver The air conditioning unit can also be switched on and off without a remote control. In order to do this, you must press the pushbutton (Fig. 118,2) (e.g. using a biro) on the infrared receiver. When the air conditioning unit is switched on at the infrared receiver, it is automatically reset to the factory setting (cooling, high fan setting, 21 °C).

The green LED (Fig. 118,3) and the red LED (Fig. 118,1) on the infrared receiver indicate the current function of the air conditioning unit.

Function display

Status LED	Signification
The green LED is flashing	The circulation fan is running, the compressor switches on after max. 3 minutes
The green LED flashes briefly	The air conditioning unit is waiting for engine to start or a function change by the remote control (only when operating with AC converter)
The green LED goes on	Cooling operation
The red LED is flashing	Data is transferred
Red LED lights up	Fault



- ▷ Further information can be obtained in the manufacturer's instruction manual.



Fig. 119 Sliding regulator for cold air distribution in the sleeping roof

Cold air distribution in the sleeping roof

The cold air flow from the air conditioning unit can also be directed into the sleeping area in the sleeping roof as required. For this purpose, a sliding regulator has been built into one of the steps of the access stairs.

For any further information see section 5.9.

9.4 Hot air / cold air nozzles

The air heated by the heater or cooled by the air conditioning unit is distributed throughout the vehicle via air nozzles.

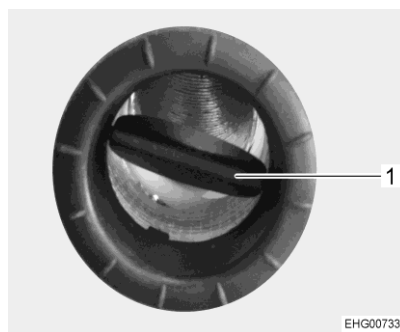

1 Flap

Fig. 120 Air nozzle (example)

The air nozzles can be closed or opened as required with the flap (Fig. 120,1).

Installation positions

Air nozzles have been installed in the following places:

Cold air nozzles (air conditioning unit):

- Stairs toward the driver's cabin
- Kitchen roof storage cabinet toward seating group
- Sleeping roof in front of mattress and above hat profile, both adjustable via sliding regulator on the stairs

Warm air nozzles (heater):

- Stairs toward secretary
- Driver's seat toward footwell
- Front passenger's seat toward footwell
- Step well
- Bathroom unit
- Front passenger's side hat profile, sliding regulator in the cabinet
- Front passenger's side seating group toward rear
- Front passenger's side seating group toward table
- Sleeping roof in front of mattress and above hat profile, both adjustable via sliding regulator on the stairs
- Driver's side seating group toward rear
- Driver's side seating group toward table

9.5 Cooker

- ▶ During operation of the gas cooker, do not leave the gas cooker unattended. Even if the gas cooker cannot be overseen for only a short time (e.g. Visit to the toilet), switch the gas cooker off.
- ▶ Never let gas escape unburned due to danger of explosion.
- ▶ Before using the cooker make sure that there is sufficient ventilation. Open a window or the skylight.
- ▶ Do not use the gas cooker for heating.
- ▶ Always protect your hands with cooking gloves or potholders when handling hot pots, pans and similar items. There is a risk of injury!
- ▶ Do not fit any curtains in the immediate proximity of the cooker. Fire hazard!
- ▶ While a burner is on, always place a pot or a pan over the flame.



- ▷ Do not place any hot objects such as cooking pans neither on the sink cover nor on the work top.

9.5.1 Gas cooker

- ▶ During activation and operation of the gas cooker, no flammable objects or highly inflammable objects such as dishcloths, napkins etc. must be near the gas cooker. Fire hazard!
- ▶ The process of ignition must be visible from above and must not be covered by cooking pans placed on the cooker.



- ▷ Only use pots and pans whose diameter is appropriate for the gas cooker burners.
- ▷ When the flame goes out, the thermocouple automatically cuts the gas supply.
- ▷ Further information can be obtained in the manufacturer's instruction manual.

The vehicle kitchen unit is fitted with a two-burner gas cooker.

Ignition The gas cooker is equipped with electronic ignition.

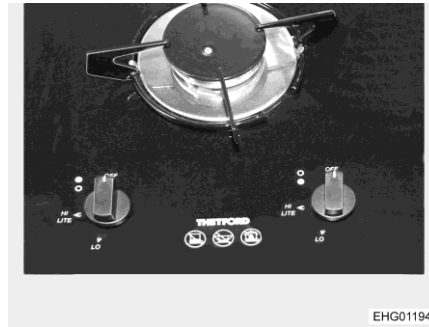

Fig. 121 Operating controls (gas cooker)

- Switching on:**
- Open the regulator tap on the gas bottle and the gas isolator tap "Cooker".
 - Turn the control knob (Fig. 121) on the burner you wish to use to the ignition position ("LITE").
 - Press the control knob down and hold it. Ignition sparks are generated at the burner.
 - Once the flame is burning, keep the control knob pressed for another 10 to 15 seconds, until the thermocouple automatically keeps the gas supply open.
 - Release the control knob and turn to the desired setting.
- Switching off:**
- Turn the control knob (Fig. 121) to the position "Off". The flame fades.
 - Close the gas isolator tap "Cooker" and the regulator tap on the gas bottle.

9.6 Refrigerator

The refrigerator is operated via the 12 V power supply. At high ambient temperatures, the refrigerator no longer achieves full cooling power or shows higher power consumption.

9.6.1 Compressor refrigerator – General



- ▶ Always keep the ventilation openings unobstructed.
- ▶ Due to technical reasons, the temperature in the refrigerator and in the freezer compartment cannot always be maintained at a constant level. Under adverse conditions, the food in the freezer compartment may thaw.



- ▷ Do not use any objects or hot air devices to accelerate defrosting.
- ▷ When the vehicle is exposed to intense sunlight: ventilate vehicle adequately.



- ▷ Before setting off, secure the products in the refrigerator against sliding.
- ▷ The living area battery has a limited power supply only. Make sure that the living area battery is always properly charged. The living area battery is charged during the journey by the alternator. While the vehicle is parked, the living area battery can be charged by shore power, a charger, or via a solar installation.



- ▷ The refrigerator temperature depends on the ambient temperature (room temperature), the frequency the door is opened with, and the filling of the refrigerator. If required, readjust the cooling level.
- ▷ Check the collection tray for condensation before setting off and periodically during operation of the refrigerator.
- ▷ Further information can be obtained in the manufacturer's instruction manual.

9.6.2 Compressor refrigerator Vitrifrigo - Operation

The refrigerator is set to the optimum refrigerating temperature at the factory. If necessary, the cooling power can be increased or decreased with the control knob on the thermostat.

Increasing the cooling power:

- Turn the control knob on the thermostat in an anticlockwise direction to the desired cooling level.

Reducing the cooling power:

- Turn the control knob on the thermostat in a clockwise direction to the desired cooling level.

The refrigerator is equipped with an automatic defrosting system. If necessary, the refrigerator can be switched off to defrost it completely.

Defrosting the refrigerator:

- Turn the control knob on the thermostat to the stop position.
- Leave the refrigerator door open.

9.6.3 Refrigerator door locking mechanism



- ▷ During the journey the refrigerator door must always be closed and locked in the closed position.



- ▷ Lock the refrigerator door in ventilation position when the refrigerator is switched off. This prevents mould forming.

There are two positions for locking the refrigerator door in place:

- Closed refrigerator door while driving and when the refrigerator is in use; locking via furniture push lock
- Slightly opened refrigerator door as a ventilation position when the refrigerator is switched off; ventilation position, see the manufacturer's instructions

Chapter overview

This chapter contains instructions regarding the sanitary fittings of the vehicle.

10.1 Water supply, general



- ▶ Fill water tank from supply systems that have been verified to provide drinking water quality.
- ▶ Only use such hoses or containers when filling that have been approved for use with drinking water.
- ▶ Thoroughly rinse filling hose or container with drinking water before use (2 to 3 times capacity).
- ▶ Empty filling hose or container completely after use and close openings of the filling hose or container.
- ▶ Water left standing in the water tank or in the water pipes becomes undrinkable after a short period. Therefore, before each use of the vehicle, thoroughly clean the water pipes and the water tank. After each use of the vehicle completely empty the water tank and the water pipes.
- ▶ In the case of lay-ups lasting more than a week disinfect the water system before using the vehicle (see chapter 11).



- ▷ If the vehicle is not used for several days or if it is not heated when there is a risk of frost, empty the entire water system. Make certain that the water pump is switched off. Otherwise, the water pump will overheat and may get damaged. Leave the water taps on in central position. Leave all drain cocks open. Frost damage to appliances, frost damage to the vehicle and deposits in water-carrying components can be avoided in this way. Remove the filter cartridge and store it frost-free.
- ▷ The water pump will overheat without water and can get damaged after one minute at the latest. Never operate water pump when the water tank is empty.

The vehicle is equipped with a fitted water tank. The access to the water tank is underneath the large floor trap in the area of the seating group. An electric water pump pumps the water to the individual water taps. Opening a water tap automatically switches on the water pump and pumps water to the tap.

The waste water tank collects the waste water. The water level in the water and waste water tanks can be checked on the panel.

Water pump

The water pump is switched on and off via the 7" panel.



- ▷ Switch on the water pump on the 7" panel before using the water fittings.
- ▷ When the water tank is re-filled, an air bubble may form at the bottom of the pump. This air bubble will prevent water from being drawn in. Shake the water pump up and down energetically in the water.

10.2 Water system

10.2.1 Water tank

The water tank holds approx. 120 l.

Position of the water tank, see section 10.2.4.

Hot air from the living area heater heats the water tank. This protects the water tank from frost.



- ▷ If the living area heater is out of order, the water tank no longer is sufficiently protected against frost. If there is a risk of frost, empty the water tank and leave the drain cock open.



- ▷ For driving safety and for regulatory reasons, when the vehicle is motion the fill quantity must be reduced to approximately 20 litres. If the water is drained using the safety drainage rotary handle (see section 10.2.4), a residual quantity of approximately 20 litres will remain in the water tank.

10.2.2 Filling the water system



- ▶ When filling the water tank, observe the technically permissible maximum laden mass of the vehicle. Luggage must be reduced accordingly when the water tank is full.
- ▶ The cap for the fuel filler neck and for the drinking water filler neck are very similar. Before filling the tank, always check the label.



- ▷ The water pump will overheat without water and can get damaged after one minute at the latest. Never operate water pump when the water tank is empty.



- ▷ While the water tank is being filled, the amount of water can be checked on the 7" panel.
 - Position the vehicle horizontally.
 - Switch on the 12 V power supply on the 7" panel.

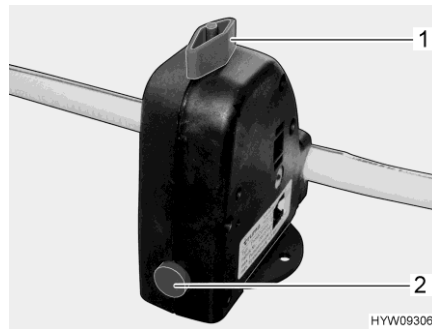

- 1 Knob
- 2 Push button

Fig. 122 Safety/drainage valve (Truma)

- Close the safety/drainage valve (Truma). Turn the knob (Fig. 122,1) perpendicular to the safety/drainage valve and push the push button (Fig. 122,2) in. The safety/drainage valve is installed underneath the cover of the first step to the sleeping roof.
- If the temperature is below 6 °C, the safety/drainage valve cannot be closed.

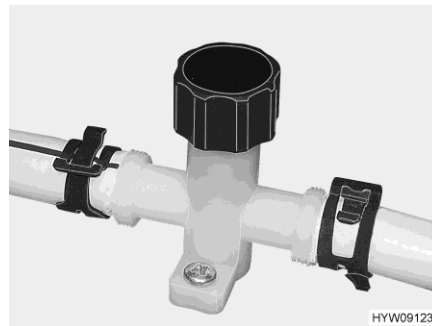

Fig. 123 Drain cock (water pipe)

- Close the drain cocks (Fig. 123). In order to do this, turn the cap in a clockwise direction, respectively. The drain cocks are installed underneath the small and the large floor plate in the area of the seating group and underneath the cover of the first step to the sleeping roof.
- Close all water taps.
- Close drainage opening on the water tank.
- Open the gas bottle compartment flap.



Fig. 124 Drinking water filler neck cover



Fig. 125 Drinking water filler neck cap



- ▷ The drinking water filler neck is located in the gas bottle compartment.
- ▷ The drinking water filler neck is marked by the symbol "🚰".

- Swivel the cover (Fig. 124) upwards.
- Insert key into locking cylinder and turn a quarter turn. The cap is unlocked.
- Remove the key.
- Turn the blue cap (Fig. 125) one quarter turn.
- Remove the cap.
- Open the drinking water filler neck on the outside of the vehicle.
- Fill the water tank with drinking water. Use a water hose certified for drinking water for filling.
- Make sure that the water filter has been inserted.
- Switch on the water pump on the 7" panel.
- Set all the water taps to "Hot" and open them. The water pump is turned on. The warm water pipes are filled with water.
- Keep the water taps open until the water flowing out of the water taps has no bubbles in it. This is the only way to ensure that the boiler is full of water.
- Set all water taps to "Cold" and leave them open. This will fill the cold water pipes with water.
- Keep the water taps open until the water flowing out of the water taps has no bubbles in it.
- Close all water taps.
- Place cap on the drinking water filler neck.
- Turn cap one quarter turn.
- Insert key into locking cylinder and turn a quarter turn. The cap is locked.
- Remove the key.
- Check that the cap sits firmly on the drinking water filler neck.
- Swivel the cover downwards.
- Close the gas bottle compartment flap.

10.2.3 Topping up the water

- Open the drinking water filler neck as described in section 10.2.2.
- Fill the water tank with a water hose certified for drinking water.
- Close the drinking water filler neck as described in section 10.2.2.

10.2.4 Reducing the water quantity for mobile operation

The access to the water tank is underneath the large floor plate in the area of the seating group.

Rotary handle The rotary handle is installed on the water tank.

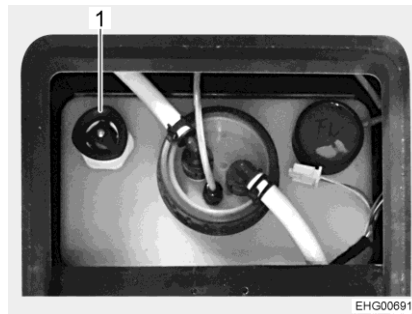

1 Rotary handle water drainage

Fig. 126 Rotary handle water drainage

- Opening:*
- Turn the rotary handle (Fig. 126,1) on the water tank 3/4 of a turn it in an anticlockwise direction. Excess water will drain away leaving approx. 20 litres in the tank.
- Closing:*
- Turn the rotary handle (Fig. 126,1) on the water tank in a clockwise direction as far as it will go.

10.2.5 Emptying the water system



- ▷ If the vehicle is not used for several days or if it is not heated when there is a risk of frost, empty the entire water system. Make sure that the 12 V power supply on the panel is switched off. Otherwise, the water pump will overheat and may get damaged. Leave the water taps on in central position. Leave the safety/drainage valve (Truma) and all drain cocks open. Frost damage to appliances, frost damage to the vehicle and deposits in water-carrying components can be avoided in this way. Remove the filter cartridge and store it frost-free.



- ▷ Take note of the environmental tip in this chapter.

To empty and ventilate the water system, proceed as follows. This will avoid frost damage:

- Position the vehicle horizontally.
- Switch off 230 V power supply.
- Switch off the 12 V power supply on the panel.
- Shut off the boiler (see section 9.2).
- Open the drain cocks. To do so, turn the cap in an anticlockwise direction or set the rocking lever in a vertical position. Positions, see section 10.2.2. The drain cock underneath the small floor plate empties the fresh water tank, the drain cocks underneath the large floor plate and the stair step empty the internal pipes.
- Open the safety/drainage valve (Truma). In order to do this, turn the knob parallel to the pipe. Position, see section 10.2.2.
- Turn the rotary handle (Fig. 126,1) on the water tank in an anticlockwise direction as far as possible beyond the resistance to fully open the drainage opening.
- Open all water taps and set to the central position.
- Hang the shower handset up in the shower position.
- Unscrew the lock ring on the water tank.
- Take water pump (fitted to the cover) as far as the connecting lines allow.
- Hold the water pump up until the water pipes are completely empty.
- Check whether the water tank is completely empty.
- Place the shower handset on the floor of the shower cubicle.
- Empty the waste water tank by means of the switch on the dashboard. Take note of the environmental tips in this chapter.
- Empty the sewage container. Take note of the environmental tips in this chapter.
- Clean the water tank and then rinse it out thoroughly.
- Let the water system dry for as long as possible.
- After emptying, leave all water taps on in the central position.
- Leave the safety/drainage valve (Truma) and all drain cocks open.

10.3 Water filter



- ▶ Do not use the water filter to filter well water, waste water, river water or rainwater. The water filter is not suitable for obtaining drinking water in this way.
- ▶ Do not use the water filter to filter hot water.
- ▶ In case of longer periods of inactivity, remove the filter and store it in a hygienic container.
- ▶ For handling the water filter safely, observe the separate instruction manual of the manufacturer (especially the safety instructions).

Purpose The water filter is only intended for filtering cold drinking water. The water filter produces hygienic fresh water from it.

Position The water filter is installed underneath a floor trap on the water tank. The filter cartridge of the water filter is connected to the filter head via a bayonet lock. The filter head has an integrated stop valve. No additional stop valves are required in the inlet and outlet.



- ▷ The procedure for changing the filter and further information can be obtained in the separate manufacturer's instruction manual.

10.4 Waste water tank

The waste water tank holds approx. 100 l.

The access to the waste water tank is underneath the large floor plate in the area of the seating group.

Hot air from the living area heater heats the waste water tank. This protects the waste water tank from frost.



- ▷ If the living area heater is out of order, the waste water tank no longer is sufficiently protected against frost. If there is a risk of frost, empty the waste water tank by means of the switch on the dashboard and leave the drain cock open.
- ▷ Never pour boiling water directly into the sink outlet. Boiling water could cause deformation and leaks in the waste water pipe system.



- ▷ Only empty the waste water tank at disposal stations, camping sites or caravan sites especially provided for this purpose.

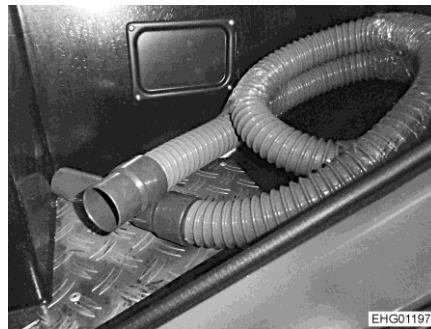

Fig. 127 Waste water hose (in the storage compartment)

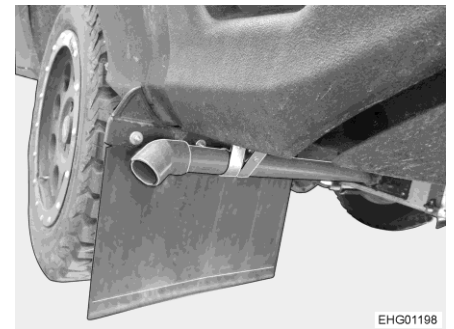
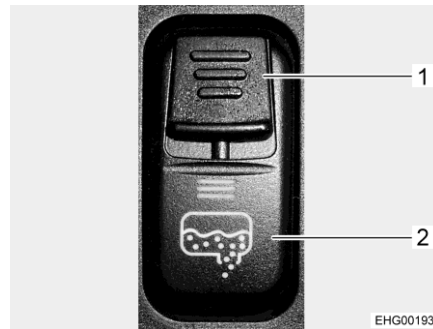

Fig. 128 Drain pipe

Waste water hose

The waste water hose (Fig. 127) is located in the gas bottle storage compartment and can be plugged onto the drain pipe (Fig. 128) as an extension. The drain cock for waste water is operated via an operating switch. The drain pipe with a connection for a waste water hose is located underneath the vehicle (behind the left-hand rear wheel).



- 1 Safety slide button
- 2 Rocker button

Fig. 129 Rocker button (drain cock)

Operating switch

The drain cock for the waste water tank is opened and closed using a rocker button of the switch panel in the driver's cabin. To prevent an unwanted opening of the drain cock, the rocker button is provided with a safety slide button (Fig. 129,1). The drain pipe with a connection for a waste water hose is located under the vehicle.



- ▷ The operation of the waste water tank drainage using the rocker button is only possible when the vehicle is standing and the vehicle engine is switched off.

Emptying:

- Position the vehicle over the outflow of the waste water disposal station or connect waste water hose and guide into outflow.
- Push the safety slide button (Fig. 129,1) on the rocker button (Fig. 129,2) downwards and, at the same time, press the lower part of the rocker button. Doing this, the waste water valve is opened and the waste water tank is emptied. The LED is lit as long as the waste water tap is open.
- Completely empty waste water tank.
- Close the drain cock again once all of the waste water has run out. To do this, press the upper part of the rocker button.
- Remove and store the waste water hose.

10.5 External shower

The vehicle is equipped with an external shower on the driver's side of the vehicle. After opening the external flap, the shower hose with shower head (Fig. 130,2) and the operating lever (Fig. 130,1) are accessible in a storage compartment.

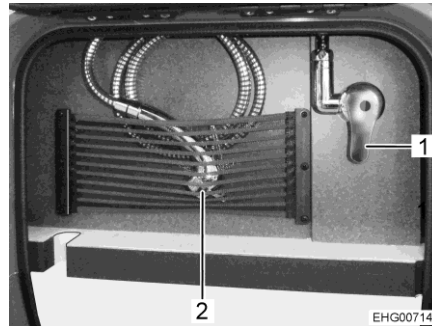

- 1 Operating lever
- 2 Shower head

Fig. 130 External shower

10.6 Bathroom



- ▷ Close the shower area before setting off.
- ▷ Do not transport any loads in the shower tray. The shower tray or other items of equipment in the toilet compartment can be damaged.



- ▷ For ventilation purposes during or after a shower, and for drying wet clothing (e.g. on the integrated clothes rail), close the toilet compartment door and open the window or the toilet compartment skylight. This improves the air circulation.
- ▷ After taking a shower, rinse soap residue from the shower tray, otherwise cracks can appear in the shower tray over time.
- ▷ After using the shower, wipe it dry to prevent moisture from collecting.
- ▷ Pitch the vehicle so that it is as horizontal as possible. Otherwise, the water from the shower tray will not be able to drain properly.
- ▷ Further information about cleaning the toilet compartment can be found in the section 11.10.5.

The bathroom can be converted into a shower and is equipped with the following components:

- Magnetic cosmetic mirror
- Wash basin
- Floor-level shower
- Shelf
- Shower column with bamboo cladding
- Swivel toilet
- Toilet pedestal with extendable access assistance

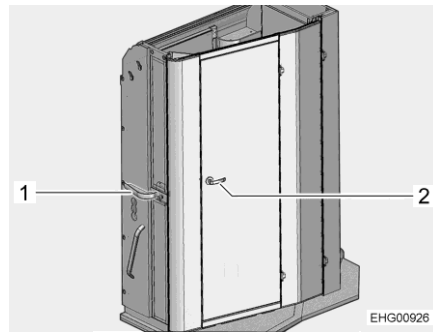

- 1 Rotary handle
- 2 Door handle

Fig. 131 Bathroom (before expansion)

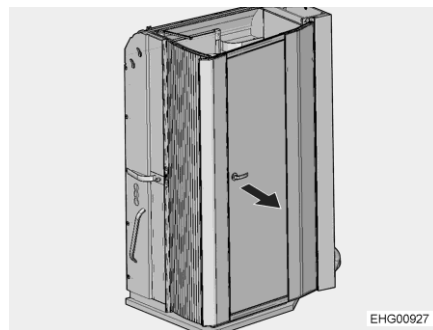

Fig. 132 Bathroom (room door pulled out)

Expanding the bathroom:

- Turn the rotary handle (Fig. 131,1) approx. 30° in an anticlockwise direction. The rotary handle is attached to the outside of the bathroom.
- Keep the rotary handle pressed and pull the closed room door outwards by the door handle (Fig. 131,2) as far as it will go (Fig. 132, arrow).



- ▷ The shower area can only be used when the bathroom is completely expanded.

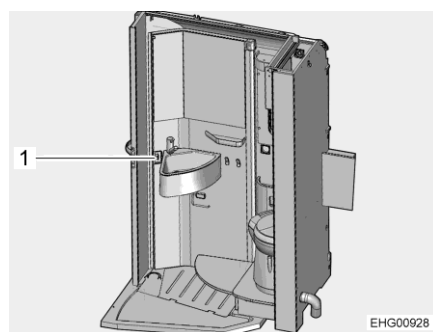

- 1 Snap lock

Fig. 133 Bathroom (exposing the shower area)

- Pull the snap lock (Fig. 133,1) to expose the shower area.

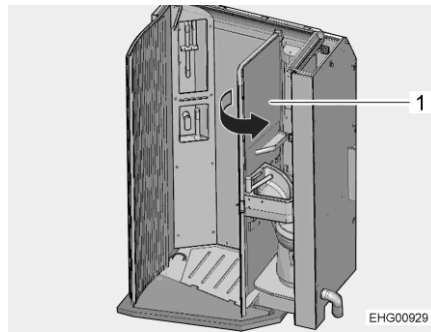

1 Hinged door

Fig. 134 Shower area

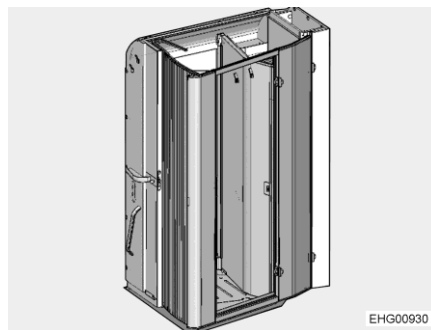
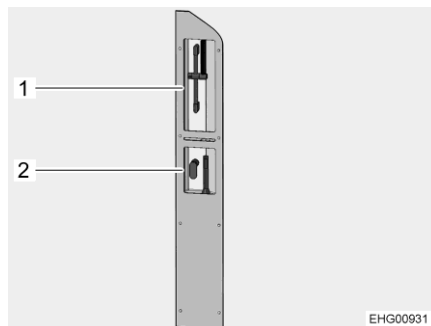

Fig. 135 Bathroom (fully expanded)

- Open the hinged door (Fig. 134,1) together with the wash basin as far as it will go (Fig. 134, arrow).



1 Shower position
2 Parking position

Fig. 136 Shower fitting

Closing the bathroom expansion:

- Detach the shower fitting from the parking position (Fig. 136,2) and insert it into the shower position (Fig. 136,1). After use, insert the shower fitting back into the parking position.
- Swing the hinged door together with the wash basin back towards the wall until it engages audibly.
- Push the closed room door by the door handle towards the wall as far as it will go.

Access assistance for toilet pedestal

The toilet pedestal is equipped with an access assistance. The access assistance is housed in a slide-in compartment and can be folded out if necessary.

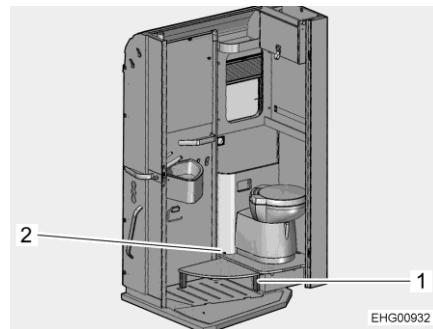

- 1 Pressure surface
- 2 Knurled screw

Fig. 137 Access assistance



- ▷ Do not pull out the access assistance by hand. The access assistance folds out automatically after pressing on the pressure surface. Pulling it out manually will damage the push-to-open system.

Using the access assistance:

- Press against the pressure surface (Fig. 137,1) with your foot. The access assistance folds out automatically thanks to the push-to-open system.

Folding in the access assistance:

- Use your foot to fold the access assistance back into its parking position.

The access assistance can also be removed for cleaning:

- Loosen the knurled screw (Fig. 137,2) until the access assistance can be removed.
- To reinsert, insert the access assistance into the slide-in compartment so that the hole on the access assistance is below the knurled screw.
- Screw the knurled screw back in.

The shelf can be removed for cleaning. When reinserting, ensure that the shelf is positioned correctly.

10.7 Toilet



- ▷ Do not load the toilet with more than a maximum of 120 kg.
- ▷ If there is any risk of frost and the vehicle is not heated, empty the sewage container.
- ▷ Do not sit on the lid of the toilet. The lid is not designed to bear the weight of a person and could break.
- ▷ Use a suitable chemical for this toilet. The ventilation will merely remove the odour but not germs and gases. Germs and gases will have a detrimental effect on the sealing rubbers.



- ▷ If the vehicle is equipped with an electrical ventilation system, the fan starts up automatically when opening the toilet slide valve.
- ▷ Further information can be obtained in the manufacturer's instruction manual.



- ▷ Only empty the sewage container at disposal stations, at camping sites or caravan sites, that are especially provided for this purpose.

10.7.1 Swivel toilet

The flushing of the Thetford toilet is fed directly from the water system of the vehicle. The toilet bowl can be moved into the optimal position.

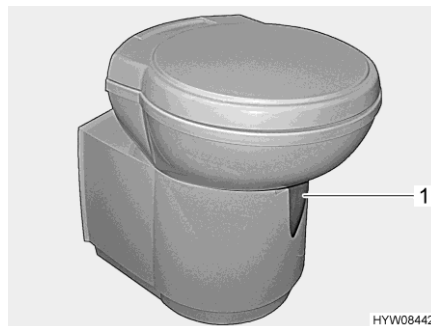

1 Slide lever

Fig. 138 Thetford toilet bowl (swivelling)

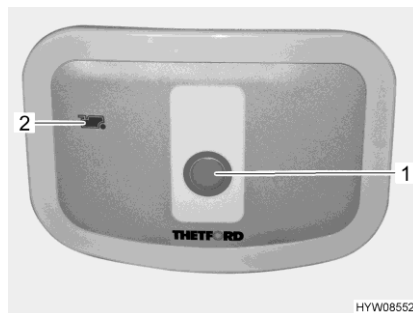

1 Flush button
2 Indicator lamp

Fig. 139 Flush button / indicator lamp (example)

The operating unit is located close to the toilet bowl.

Flushing:

- Before flushing open the sliding trap of the Thetford toilet. To do this, push the slide lever (Fig. 138,1) in an anticlockwise direction.
- For flushing, press the blue flush button (Fig. 139,1).
- After flushing close the sliding trap. To do this, push the slide lever in a clockwise direction.

The indicator lamp (Fig. 139,2) lights up whenever the sewage container needs to be emptied.

10.7.2 Empty sewage container



- ▷ Before emptying the sewage container, remove the hose of the ventilation system from the sewage container.



- ▷ The sewage container can only be taken out if the sliding trap is closed.



Fig. 140 Flap (sewage container)

- Slide the slide lever on the toilet bowl in a clockwise direction. The sliding trap is closed.
- Open the flap for the sewage container on the outside of the vehicle. In order to do this, insert the key into the locking cylinder of the lock handle (Fig. 140) and turn a half turn in an anticlockwise direction.
- Remove the key.
- Turn the lock handle half a turn in an anticlockwise direction and open the flap for the sewage container.

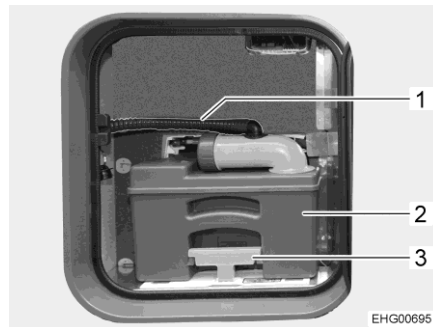

- 1 Hose
- 2 Sewage container
- 3 Retaining clip

Fig. 141 Sewage container (in vehicle)

- Pull off the hose (Fig. 141,1) of the ventilation system.
- Pull up the retaining clip (Fig. 141,3) and pull out the sewage container (Fig. 141,2).

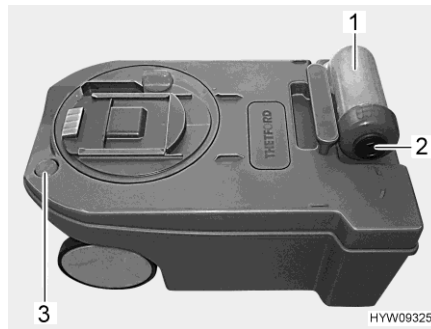

- 1 Outlet pipe
- 2 Cover
- 3 Ventilation button

Fig. 142 Sewage container

- At a disposal station that is especially provided for this purpose, swivel the outlet pipe (Fig. 142,1) forwards and unscrew cover (Fig. 142,2).
- Press the coloured ventilation button (Fig. 142,3) and hold it there until the sewage container is empty.
- Clean the sewage container with fresh water.
- Close outlet pipe with cover and swivel it back.
- Push sewage container into the disposal chute until it engages.
- Connect the hose of the ventilation system.
- Close flap for sewage container.
- Fill in new sanitary liquid.

10.7.3 Automatic SOG toilet ventilation (optional)

The automatic SOG toilet ventilation draws in the air in the toilet compartment, leads it through the sewage container and then outside via an outlet in the floor.

When the toilet slide is opened, the SOG toilet ventilation starts automatically.

Position of active carbon filter

The active carbon filter (green filter cartridge) is installed in the right-hand bench.

Replacing the active carbon filter:

- When replacing the active carbon filter, proceed as described in the manufacturer's separate instruction manual.



- ▷ Further information can be obtained in the manufacturer's instruction manual.

10.7.4 Winter operation



- ▷ Do not use anti-freeze. Anti-freeze can damage the toilet.

When the vehicle is being heated, the toilet, the water tank and the sewage container are in a frost-protected area. This means that the toilet can also be used in winter.

If the vehicle is not being heated and there is a risk of frost, empty the water tank, the sewage container and the water pipes. This prevents frost damage.

10.7.5 Temporary lay-up



- ▷ If the toilet is not to be used for an extended period, empty the water tank, the sewage container and the water pipes.

Laying up the toilet:

- Empty the water tank.
- Flush the toilet until no more water runs into the toilet. Note that the pump can get damaged after one minute at the latest if it runs dry.
- Empty the sewage container.
- Rinse the sewage container thoroughly.
- Leave the drainage neck on the sewage container open.
- Allow the sewage container to dry.

Chapter overview

This chapter contains instructions regarding the care of the vehicle.

At the end of the chapter there is a checklist of measures you must carry out if you are not going to use the vehicle for an extended period of time.

11.1 General



- ▷ The vehicle is designed for recreational use. Use that goes beyond normal recreational use (permanent use) can lead to moisture forming in the interior. In addition, the interior may be affected.

11.2 External care

Standard external care consists of regular washing. The use and the environmental conditions will determine how often the vehicle needs to be washed. Wash the vehicle more frequently in areas which are exposed to heavy air pollution or heavy traffic or roads treated with de-icing salts. If the vehicle is exposed to salty and humid air (coastal areas, humid climates), wash the vehicle more frequently.

Do not park under trees if at all possible. The resin-like discharge which many trees secrete, give the paintwork a matt look and can promote the onset of corrosion.

Wash off bird droppings straight away and thoroughly, as the acid it contains is extremely corrosive.

11.2.1 Washing with a high-pressure cleaner



- ▷ Do not clean the tyres with a high-pressure cleaner. The tyres might be damaged.
- ▷ Do not spray external applications (deco-films) directly with the high-pressure cleaner. The external applications could come off.
- ▷ Do not clean the bellows of the sleeping roof with a high-pressure cleaner. The foil would otherwise be damaged and the sleeping roof would no longer be able to extend.

Before washing the vehicle with a high-pressure cleaner, observe the operating manual of the high-pressure cleaner.

When cleaning with the nozzle for circular jet between the vehicle and the cleaning nozzle, maintain a minimum distance of approx. 700 mm.

Take into consideration that the jet of water comes out of the cleaning nozzle with pressure. The vehicle may be damaged by incorrect handling of the high-pressure cleaner. The temperature of the water should not be above 60 °C. Keep the jet of water in constant movement during the washing process. Do not direct the water jet at clearances, built-in electrical parts, plugs, seals, the ventilation grill or the skylights. The vehicle may be damaged or water may enter the interior.

11.2.2 Washing the vehicle



- ▷ When cleaning in automatic car washes, water may penetrate openings such as the refrigerator ventilation grille or waste gas vent. Never clean the vehicle in an automatic car wash. When washing by hand, make sure that no water enters through the openings.
- Wash the vehicle only on a washing site intended for this purpose.
- When cleaning in direct sunlight, make sure that the cleaning agent used does not cause harmful reactions.
- When using a cleaning agent, observe the manufacturer's instructions for use. Cleaning agent must be pH-neutral.
- First, test the suitability of the cleaning agent on an inconspicuous spot.
- Only clean external applications and synthetic parts with plenty of warm water, dish washing liquid and soft cloth.
- Wash down the vehicle with plenty of water, a clean sponge or a soft brush. In the case of stubborn dirt add dish washing liquid to the water.
- Painted exterior walls may also be cleaned with a caravan cleaner.
- Do not treat rubber seals with agents that are corrosive or contain silicone (e.g. alcohols, plasticisers, organic solvents). It is possible to use talcum or white Vaseline without any problems. HYMER recommends a high-quality, perfluorinated lubricant to treat the rubber.
- Treat locking cylinder of doors and storage flaps with graphite dust.

11.2.3 Windows of acrylic glass

Acrylic glass windows are delicate and require very careful handling.



- ▷ Never rub acrylic glass windows dry as dust particles might damage the surface.
- ▷ Only clean acrylic glass windows with plenty of warm water, some dish washing liquid and a soft cloth.
- ▷ Never use glass cleaning agents with chemical, abrasive or alcohol-containing additives. Premature brittleness of the panes and associated cracks may result from their use.
- ▷ Avoid contact of cleansing agents used for the body (e.g. tar- or silicone-removing agents) with acrylic glass.
- ▷ Do not clean vehicle in car wash.
- ▷ Do not attach stickers to the acrylic glass windows.
- ▷ Having cleaned the vehicle rinse acrylic glass with sufficient clear water.
- ▷ Treat rubber seals with a conventional rubber care product.



- ▷ An acrylic glass cleanser with antistatic effect is suitable for a follow-up treatment. Small scratches can be treated with an acrylic glass polish. These agents are available at the accessories shop.

11.2.4 Add-on parts made of glass-fibre reinforced plastic (GRP)



- ▷ Avoid contact between polish and window rubber and piping.
- ▷ The glass-fibre reinforced plastic (GRP) may not become too hot. Therefore when polishing with a polishing machine, keep the machine in constant motion.



- ▷ In the case of large-surface GRP components, superficial cracking may occur due to ageing. This is a property of the GRP material composite with GelCoat coating that does not affect the function of the component. Therefore, there is no reason for complaint.

Add-on parts made of GRP can yellow or weather due to lack of vehicle care and material ageing.

GRP add-on parts should therefore undergo regular follow-up treatment. This way, these parts will not turn yellow and the sealing of the surface remains intact.

Follow-up treatment of GRP add-on parts:

- Wash the vehicle and allow to dry as described above. Check if the GRP add-on parts are clean and dry.
- Apply the polisher with a soft cloth evenly on the surface of the GRP add-on part.
- Wait until a light grey film forms.
- Wipe the GRP add-on part with a dry, soft cloth. Move the cloth in circles over the surface of the GRP add-on part.

We recommend using a polishing machine for this work.



- ▷ Paint protection has to be used to preserve the polish. Please read the instructions of the paint protection for details on how to apply it.

11.2.5 Underbody

The underbody of the vehicle is partly coated with an age-resistant underbody protection. Should the underbody protection be damaged, repair immediately. Do not treat areas coated with underbody protection with spray oil.



- ▷ Before treatment with underbody protection:
Cover the air conditioning unit's supply air openings (in the vehicle floor). Otherwise the air conditioning unit could be damaged. Remove the covers after work has been completed.



- ▷ Only use products approved by the manufacturer. Our authorised dealers and service centres will be happy to advise you.

11.2.6 Engine compartment



- ▷ Cleaning and care of the engine compartment may only be carried out while the ignition is switched on.
- ▷ Let the engine cool down before carrying out any work in the engine compartment. There is a danger of burns when touching motor components that are still hot!
- ▷ Before carrying out any work in the engine compartment, read and observe the corresponding warning and handling instructions in the operating manual of the base vehicle manufacturer.
- ▷ Have an engine washing only carried out by an authorised specialist workshop.
- ▷ Do not aim the steam jet directly at the lamp housings, actuators or seals. This may prevent humidity in the headlights and the defects resulting therefrom.
- ▷ Do not aim the steam jet at the windscreen wiper motor and the wiper mechanics.
- ▷ Only apply protective engine lacquer when the components in the engine compartment have cooled down and are clean.
- ▷ Only use lubricants, greases and fluids authorised by the base vehicle manufacturer.

The body manufacturer excludes any guarantee for damages, leaks, or the failure or electrical components that appear after an engine washing.

11.2.7 Windscreen washer system and windscreen wipers



- ▷ Only fill the cleaning agents (with/without frost protection) into the washer fluid container which are listed in the operating manual of the base vehicle manufacturer and in the mixing ratio specified therein. Do not use any radiator frost protection or other products. These products affect the cleaning effect and attack the windscreen blades.
- ▷ Do not switch the windscreen washer system or the windscreen wipers on when the windscreen blades are frozen to the windscreen. Release the windscreen blades first using a defrosting product.
- ▷ Do not remove the snow accumulated on the windscreen with the windscreen wipers. Remove the snow from the windscreen with a brush first.
- ▷ Do not switch on the windscreen wipers on a dry windscreen.
- ▷ Do not clean the windscreen wiper mechanics and the windscreen wiper motor with a steam blaster.
- Check the correct functioning of windscreen washer system and windscreen wipers periodically.
- Check the filling level of the washer fluid container periodically. Only if sufficient cleaning fluid reaches the windscreen, the windscreen wipers will be able to clean it in a satisfactory way. A clear view contributes decisively to safe driving.
- Before the frost period starts, fill the washer fluid container with windscreen cleaning product containing sufficient frost protection.

- Refill windscreen washing fluid on time. Only use clean water to dilute the windscreen cleaning product.
- Remove insect residues from the windscreen blades as soon as possible.
- Clean the windscreen blades periodically with a windscreen cleaning product. To do this, move a sponge or a cloth along the rubber strip.
- Remove car wax residues after the vehicle washing using a wax dissolving windscreen cleaning product.
- Remove dirt accumulations on the nozzles of the windscreen washer system periodically.
- After journeys on heavily soiled roads, spray clear water on the wiper nozzles to prevent incrustations.
- Clean obstructed wiper nozzles with a fine needle.

11.3 Air conditioning unit



- ▷ Do not clean the air conditioning unit with a high-pressure cleaner. Water entering can damage the air conditioning unit.
- ▷ When cleaning the underbody, make sure that no water gets into the air conditioning unit's supply air openings (in the vehicle floor). Otherwise the air conditioning unit could be damaged.
- ▷ Do not clean vehicle in car wash.
- ▷ Do not use any sharp or hard objects when cleaning. Otherwise the air conditioning unit could be damaged.

- Use only water and a gentle cleaning agent to clean the air conditioning unit.
- Wipe the air conditioning unit housing and the air outlet occasionally with a damp cloth.
- Clean the remote control occasionally with a slightly damp cloth. Clean the display with a spectacles cleaning cloth.
- Keep the supply air openings (in the vehicle floor) free of dirt and slush.
- Check the condensation drain holes regularly to ascertain whether the condensation can run off freely.
- Clean the lint filter regularly (at least twice a year).



- ▷ Further information can be obtained in the manufacturer's instruction manual.

11.3.1 Entrance step

If the entrance step is lubricated, coarse particles of dirt can settle on the lubricant during the journey and cause damage to the operating mechanism of the entrance step. Therefore, do not lubricate the moving parts of the entrance step.

11.4 Interior care



- ▷ If possible, treat stains immediately.
- ▷ Synthetic parts in the toilet and living area are very delicate and should be treated with care. Do not use solvents, alcohol-containing cleansers or scourers. This procedure will help you to avoid brittleness and formation of cracks.
- ▷ Hair colourants, nail varnish, cigarette ash and similar substances may cause permanent stains or discolouration. For this reason, you should prevent these substances from getting onto plastic parts. If they do get onto plastic parts, you should remove these substances immediately.
- ▷ Do not pour any corrosive agents into the drain holes. Never pour boiling water directly into the drain holes. Corrosive agents and boiling water cause damage to drainage pipes and siphon traps.
- ▷ Do not use vinegar based products to clean the toilet and water system, or for descaling the water system. Vinegar-based products may cause damage to seals or parts of the installation. Use standard descaling products for descaling.
- ▷ Save water. Mop up all remaining water.



- ▷ For information about the use of maintenance products, our representatives and service centres will be glad to advise.
- Surface and knobs of furniture, lamps and synthetic parts in the toilet and living area should be cleaned with water and a wool cloth. A mild cleanser may be added to the water. If required, use furniture polish for the painted surfaces.
 - Curtains and net curtains should be dry cleaned.
 - Vacuum clean the carpet, if necessary clean with carpet shampoo.
 - Clean PVC-floor covering with a mild, soapy cleaning agent for PVC floors. Do not place carpet on wet PVC-floor covering. The carpet and the PVC-floor covering may stick together.
 - Brush insect screen with a soft brush or vacuum with the brush attachment of the vacuum cleaner.
 - Brush blinds with a soft brush or vacuum with the brush attachment of the vacuum cleaner. Grease or stubborn dirt may be removed with a mild soap at 30 °C (curd soap).
 - Brush Roman shades with a soft brush or vacuum with the brush attachment of the vacuum cleaner. Grease or stubborn dirt may be removed with a mild soap at 30 °C (curd soap).
 - Unrolled seat belts can be cleaned with warm soapsuds. The seat belt must be completely dry before being rolled up.

11.5 Kitchen installation

11.5.1 General notes on care

- Never clean the sink or the gas cooker with a scourer. Avoid anything which may cause scratching or grooves.
- The surface of the kitchen worktop is not scratch proof. When working with sharp objects, always use a pad. Only use soft cleaning agents for cleaning and care. Do not use any abrasive or scratching intensive treatment products nor scratching sponges.
- Clean the sink cover manually using water and washing-up liquid. Do not clean the sink cover in the dishwasher.
- Clean the burners on the gas cooker using a damp cloth only. Prevent any water from penetrating the burner covers. Water may damage the burners on the gas cooker.
- When cleaning the burner ring, ensure that the holes are not obstructed.
- Clean the surface of the cooker, and particularly the hob, with warm water and some washing-up liquid. Scouring agent or sharp objects damage the surface of the hob.
The surface of the hob is easier to clean when it is still slightly warm. Before cleaning, ensure that the hob is only still warm to the touch (residual heat indicator has gone out). Always clean the hob before using it again.
- The knobs can be pulled off for cleaning.
- Clean the external surfaces of the kitchen installation with a wet cloth without abrasive, corrosive or chloride containing cleaning agents. Do not use any steel wool.
- Immediately remove acidic or alkaline substances (vinegar, salt, lemon juice, etc.).
- Let the oven and grill cool down before cleaning. Hot surfaces may be damaged due to cold water or a wet cloth. Clean enamelled surfaces only with soap water or washing-up liquid containing water.

11.5.2 Refrigerator

- Remove shelves, grids, etc. from the refrigerator and clean the inside of the refrigerator with warm water. Washing soda or vinegar can be added to the water. Then wipe with clear water and dry with a soft cloth.
- Do not use abrasive or aggressive cleaning agents or soap to clean the refrigerator.
- Keep oil and grease away from the door seal.

11.6 Stainless steel surfaces



- ▷ Do not clean the stainless steel surfaces with bleaching agents, with products that contain chloride or hydrochloric acid, baking powder nor with silver polish.
- ▷ Do not use scouring agent nor coarse sponges.



- ▷ Prior to cleaning, test the suitability of the cleaning product for the surface on an unobtrusive spot.
- ▷ Dry the surfaces thoroughly after cleaning to prevent limescale.
- ▷ In the case of brushed stainless steel surfaces, wipe in a direction of the grinding.

Removing scratches from the surface:

- Treat the stainless steel surface with a soft cleaning cloth and with a special stainless steel cleaner.
- Rinse the stainless steel surface and dry it with household wipes.

Removing stubborn dirt and burnt-in fat:

- Clean the stainless steel surface with an ordinary household sponge and with cleanser.
- Rinse the stainless steel surface and dry it with household wipes.

Removing fingerprints:

- Clean the stainless steel surface with a soft cleaning cloth and soapy water or a glass cleaning agent.
- Rinse the stainless steel surface and dry it with household wipes.

Removing coffee or tea stains:

- Treat the stainless steel surface with a baking soda solution. Allow the baking soda solution to work in for 15 minutes.
- Rinse the stainless steel surface and dry it with household wipes.

Removing rust stains:

- Clean the stainless steel surface with an ordinary household sponge and with cleanser. If necessary, use a soft cleaning cloth and stainless steel cleaner.
- Rinse the stainless steel surface and dry it with household wipes.

11.7 Cushions

The care and cleaning instructions below are for assistance only. They are not a guarantee of successful cleaning. These instructions cannot form the basis for any warranty claims.



- ▷ If possible, treat stains immediately.
- ▷ Never use household cleaners to remove stains (e.g. detergents).
- ▷ Before treating stains, test the cleaning on a hidden part of the upholstery covers. This will show you whether the cleaning will damage the materials or dyes.
- ▷ Always only dab moist or greasy stains, never rub them. It is most effective to gently press an absorbent cloth or a sponge onto the stain.
- ▷ Do not wash upholstery.
- ▷ When cleaning leather covers, make sure that the leather is not soaked through and that no water seeps through the seams of the leather covers.



- ▷ Treat the stain from the outside working inwards. This prevents the stain from spreading.
- ▷ In the case of both solid or softer contamination, first remove the coarse parts. Next, carefully scrape off the stain with a blunt knife or spatula.
- ▷ If the stain has already dried in, carefully brush off the coarse parts. Next, dab off the stain with a damp cloth or sponge.
- ▷ The upholstery will fade over time, if it is exposed to sunlight. If the temperature within the vehicle rises rapidly as well, the colour will change at an accelerated rate. Therefore, we recommend to close the shades on the windows when there is strong sunlight. Ensure that heat does not build up when you close the blind.
- ▷ Depending on the equipment, the cushions will be provided with stain protection.

Removing grease, oil, wine, milk, non-alcoholic beverages:

- Moisten a cloth with commercial water-based cleaning agent. (Alternatively, mix 2 tablespoons of ammoniac with 1 litre of water.)
- Gently dab the stain with the cloth.
- Turn the cloth frequently so that the stain only comes into contact with a clean part of the cloth.

Removing urine, sweat:

- Moisten a cloth with commercial water-based cleaning agent. (Alternatively, mix 2 tablespoons of ammoniac with 1 litre of water.)
- Gently dab the stain with the cloth.
- Turn the cloth frequently so that the stain only comes into contact with a clean part of the cloth.

Removing chocolate, coffee:

- Moisten cloth with lukewarm water.
- Dab the stain with the cloth.

Removing fruit residues:

- Moisten cloth with cold water.
- Dab the stain with the cloth.

Removing wax:

- Carefully scrape off the wax with a blunt knife or spatula.
- Cover the stain with several layers of blotting paper and iron it.

Removing blood:

- Mix 2 tablespoons of salt and 1 litre of water.
- Moisten the stain and dab with a dry cloth.
- Dab stubborn stains with ammonia solution.

Removing (ball pen) ink:

- Moisten cloth with benzine.
- Gently dab the stain with the cloth.
- Turn the cloth frequently so that the stain only comes into contact with a clean part of the cloth.

- Removing mud:*
- Carefully remove as much mud as possible with a blunt knife or a spatula.
 - Allow the mud to dry and then remove it with a vacuum cleaner.
 - For stubborn stains, moisten a cloth with commercial water-based cleaning agent. (Alternatively, mix 2 tablespoons of ammonia solution with 1 litre of water.)
 - Gently dab the stain with the cloth.
 - Turn the cloth frequently so that the stain only comes into contact with a clean part of the cloth.
- Removing pencil:*
- Moisten cloth with a mild, water-free and pure fabric cleaning agent.
 - Gently dab the stain with the cloth.
 - Turn the cloth frequently so that the stain only comes into contact with a clean part of the cloth.
- Removing vomit:*
- Carefully remove vomit.
 - Wash cushion with cold water.
 - Moisten a cloth with commercial water-based cleaning agent. (Alternatively, mix 2 tablespoons of ammoniac with 1 litre of water.)
 - Gently dab the stain with the cloth.
 - Turn the cloth frequently so that the stain only comes into contact with a clean part of the cloth.

11.8 Sleeping roof

The 3D-TEX material of the sleeping roof is a technical textile that can be moulded into a three-dimensional component by blowing in air. Coatings ensure that the material is airtight and durable in accordance with the application requirements.

The care and cleaning instructions below are for assistance only. They are not a guarantee of successful cleaning. These instructions cannot form the basis for any warranty claims.



- ▷ If possible, treat stains immediately.
- ▷ Before treating stains, test the cleaning process on a hidden area. This allows you to determine whether the cleaning affects the fabric or the colour.
- ▷ Always only dab moist or greasy stains, never rub them. It is most effective to gently press an absorbent cloth or a sponge onto the stain.
- ▷ Colouring products can leave a residue on the 3D-TEX material (e.g. red wine, sauce, ketchup, coffee, wood glue, fibre pens, varnish, mascara, toilet cleaner, used oil).
- ▷ Organic substances can leave a residue on the 3D-TEX material (e.g. bird droppings, mould).
- ▷ Coloured products can leave a stain on the 3D-TEX material (e.g. printed paper, jeans, PVC plasticisers).



- ▷ Treat the stain from the outside working inwards. This prevents the stain from spreading.
- ▷ In the case of both solid or softer contamination, first remove the coarse parts. Next, carefully scrape off the stain with a blunt knife or spatula.
- ▷ If the stain has already dried, carefully brush or vacuum off the coarse particles. Next, dab off the stain with a damp cloth or sponge.

Removing beer, grease, oil, white wine, milk, non-alcoholic beverages:

- Moisten a cloth with commercially available water-based washing-up liquid.
- Gently dab the stain with the cloth.
- Turn the cloth frequently so that the stain only comes into contact with a clean part of the cloth.

Removing blood, urine, sweat:

- Moisten a cloth with commercially available water-based washing-up liquid.
- Gently dab the stain with the cloth.
- Turn the cloth frequently so that the stain only comes into contact with a clean part of the cloth.

Removing (ball pen) ink:

- Moisten a cloth with water-based washing-up liquid.
- Gently dab the stain with the cloth.
- Turn the cloth frequently so that the stain only comes into contact with a clean part of the cloth.

Removing mud:

- Carefully remove as much mud as possible with a blunt knife or a spatula.
- Allow the mud to dry and then remove it with a vacuum cleaner.
- For stubborn stains, moisten a cloth with commercially available water-based washing-up liquid.
- Gently dab the stain with the cloth.
- Turn the cloth frequently so that the stain only comes into contact with a clean part of the cloth.

Removing vomit:

- Carefully remove vomit.
- Moisten a cloth with commercially available water-based washing-up liquid.
- Gently dab the stain with the cloth.
- Turn the cloth frequently so that the stain only comes into contact with a clean part of the cloth.

Removing shoe wax, wax crayon, candle wax, hair wax:

- Moisten a cloth with commercially available water-based washing-up liquid.
- Gently dab the stain with the cloth.
- Turn the cloth frequently so that the stain only comes into contact with a clean part of the cloth.

Removing glue residues, adhesive residues, fabric tape:

- Moisten a cloth with commercially available water-based washing-up liquid.
- Gently dab the stain with the cloth.
- Turn the cloth frequently so that the stain only comes into contact with a clean part of the cloth.

Removing body care products, make-up products, room care products:

- Moisten a cloth with commercially available water-based washing-up liquid.
- Gently dab the stain with the cloth.
- Turn the cloth frequently so that the stain only comes into contact with a clean part of the cloth.

Removing lubricating oil, grease, white spirit, brake cleaner, WD40, cockpit spray, antifreeze, de-icer spray:

- Moisten a cloth with commercially available water-based washing-up liquid.
- Gently dab the stain with the cloth.
- Turn the cloth frequently so that the stain only comes into contact with a clean part of the cloth.

11.9 Bamboo solid wood panels

Bamboo wood is a natural product and is subject to climatic and geographical influences that affect the appearance and structure of the wood. The visual and haptic properties of the solid bamboo wood panels used in the vehicle mentioned below are not a quality defect and do not constitute grounds for complaint:

Colour differences, brightness differences, discolourations

The wood surface is essentially influenced by the intensity of weathering such as rain, wind, sun and UV radiation. Experience shows: the more sunlight and UV radiation hit the bamboo wood, the lighter it becomes. Moisture in turn makes bamboo wood darker.

Haptic changes of the surface

Drying cracks, rough surfaces as well as splintering have no influence on the static properties and durability of the bamboo wood and are generally permissible.



- ▷ Avoid prolonged direct sunlight and exposure to moisture and humidity.
- ▷ Care for the bamboo wood at regular intervals (every 2 years) by means of suitable agents.



- ▷ Bamboo solid wood panels (upright slats) in various thicknesses are built into the vehicle.

Bamboo solid wood panels are installed in the vehicle in the following places:

- Cover of the steps of the access stairs
- Table top
- Desk top of the secretary
- Shower console in the bathroom
- Rear platform

Cleaning Depending on the state of care, location and ventilation situation of the bamboo solid wood panels, top-porous impurities can develop over time. This is a natural process that cannot be completely ruled out even with optimal compliance with cleaning and care intervals.

- Clean bamboo solid wood panels with suitable agents.

Care of the rear platform

The rear platform covered with bamboo solid wood panels can be used like a terrace and is therefore subject to a variety of usage and weather influences. Special care is required to prevent the colouring from changing significantly or the natural weather protection from weakening.

- Clean bamboo solid wood panels with suitable agents.
- Regularly oil bamboo solid wood panels with a bamboo care oil. HYMER recommends the natural trend oil from Zweihorn for this purpose.

11.10 Water system

11.10.1 Cleaning the water tank

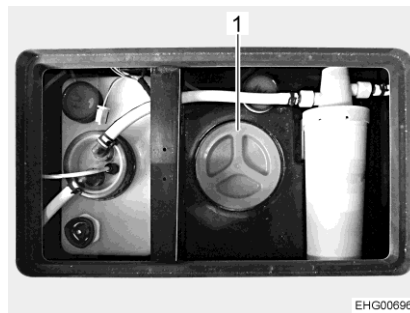

1 Cap

Fig. 143 Cleaning opening (water tank)

- Empty the water tank and close the drainage opening.
- Remove the cap (Fig. 143,1) of the water tank.
- Fill water tank with water and some washing-up liquid (do not use any scourers).
- Using a trade standard brush for washing dishes, scrub the water tank until there is no longer any visible deposit.
- Scrub also the pump housing.
- If possible, clean fresh water sensors through the cleaning openings by hand.
- Rinse water tank with copious amounts of drinking water.



▷ If, due to the design of the water tank, it is not possible to clean the water tank mechanically: Use a suitable chemical cleaning agent.

The authorised dealers would be happy to assist you in choosing a suitable cleaning agent.

Follow the cleaning agent manufacturer's instructions.

11.10.2 Cleaning the water pipes



- ▷ Only use approved cleaning agent as sold by the specialist trade.
- ▷ The cleaning agent must meet national regulations and be approved (if required).



- ▷ Collect any emerging mixture of water and cleaning agent for correct disposal.

- Empty the water system.
- Close all drainage openings and drain cocks.
- Fill mixture of water and cleaning agent into the water tank. Observe the manufacturer's instructions regarding the mixing ratio.
- Open the drain cocks one by one.
- Leave the drain cocks open until the mixture of water and cleaning agent has reached the respective drain.
- Close the drain cocks.
- Set all the water taps to Hot and open them.
- Leave the water taps open until the mixture of water and cleaning agent has reached the drain.
- Set all water taps to Cold and open them.
- Leave the water taps open until the mixture of water and cleaning agent has reached the drain.
- Close all water taps.
- Flush the toilet several times.
- Allow the cleaning agent to act in accordance with the manufacturer's instructions.
- Empty the water system. Collect the mixture of water and cleaning agent for correct disposal.
- For rinsing fill the entire water system with drinking water and empty again several times over.

11.10.3 Disinfecting the water system



- ▷ Only use approved disinfectants as sold by the specialist trade. Observe the tolerance of humans and animals.
- ▷ The disinfectant must meet national regulations and be approved (if required).



- ▷ Collect any emerging mixture of water and disinfectant for correct disposal.

When disinfecting the water system, proceed the same way as when cleaning the water pipes (see section 11.10.2). Simply use disinfectant instead of cleaning agent.

11.10.4 Cleaning the waste water tank

Clean the waste water tank after every use.



Fig. 144 Cleaning opening (waste water tank)

Cleaning:

- Empty the waste water tank.
- Open the cleaning opening (Fig. 144) on the waste water tank and the drain cock.
- Thoroughly rinse out the waste water tank with fresh water.
- If possible, clean waste water sensors through the cleaning opening by hand.

The access to the waste water tank is underneath the large floor plate in the area of the seating group.

11.10.5 Siphons

Wash basin siphon

The siphon for the wash basin is located behind a cover (Fig. 145).

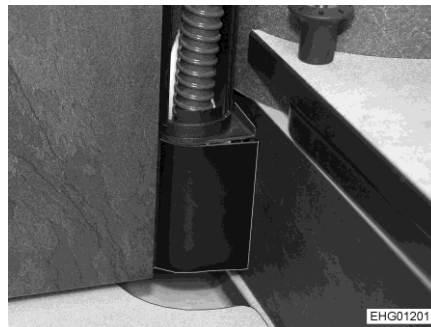
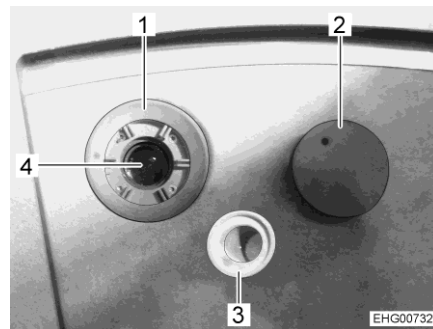

Fig. 145 Wash basin siphon

Shower tray siphon

The shower tray siphon is located underneath the jigsaw insert grate.



- 1 Siphon
- 2 Cap
- 3 Inner part
- 4 Shower base

Fig. 146 Shower tray siphon

Cleaning:

- Remove the jigsaw insert grate.
- Unscrew the cap (Fig. 146,2) and remove it from the siphon (Fig. 146,1).
- Take out the inner part (Fig. 146,3) from the siphon.
- Clean the shower base (Fig. 146,4).
- Insert the inner part.
- Place the cap on the siphon and tighten it.
- Insert the jigsaw insert grate.

11.11 Care for vehicle operation in winter

De-icing salt damages the underbody and the parts open to water spray. We recommend that you wash the vehicle more frequently during wintertime. Mechanical and surface treated parts and the underside are under particular strain, and should therefore be cleaned thoroughly.



- ▷ If there is any risk of frost, always run heater at a minimum of 15 °C. Switch the circulation fan (if there is one) to automatic. In the case of extreme external temperatures, the furniture flaps and doors should be left slightly open. The inflowing warm air can help prevent the freezing of water pipes, for example, and counteract the formation of condensation in the storage spaces.
- ▷ If there is a risk of frost, additionally cover the windows on the outside of the vehicle overnight with winter insulation mats.

11.12 Lay-up

11.12.1 Temporary lay-up



- ▶ Take into consideration that water is undrinkable after only a short time.
- ▶ Animal damage to cables can lead to short circuits. Fire hazard!

Animals (especially mice) can cause great damage to the interior of the vehicle. This is especially true if the animal remains undisturbed in a parked vehicle.

To keep damages from animals to a minimum or to avoid them altogether, regularly check the vehicle for damage or animal traces.

If animal traces are found, contact the authorised dealer or service centre. If damage to cables has occurred, they can result in short circuits. The vehicle could catch fire.

11.12.2 General/winter lay up

If the vehicle is to be put out of operation for a longer period of time (e.g. at the end of the travel season), some measures must be taken so that a smooth start is possible when the vehicle is put back into operation.

The focus is not only on the base vehicle or chassis, but also on the entire living area with all the components installed in it (water system, gas system, electrical system, furniture, cushions).



- ▷ On vehicles with a battery capacity indicator, the data are reset when the main switch on the transformer/rectifier is switched off. Therefore, when putting the system back into operation, a complete charging cycle must be carried out in order to calibrate the system. In addition, the date and time must be reset.

Carry out the following measures prior to a lay-up:

Base vehicle

General lay-up measures	Done
Completely fill fuel tank. This can prevent corrosion damage to the inner wall of the fuel tank	
Increase tyre air pressure by 0.5 bar to prevent damage when stationary	
Take the weight off the wheels or move the vehicle every 3 to 4 weeks. In the case of parking sites with natural soil, place suitable wooden or plastic plates underneath the wheels if necessary	
Protect the tyres from direct exposure to the sun. Danger of formation of cracks!	
Check the tyres. Do not continue to use worn tyres or tyres that are more than 6 years old	
Ensure good ventilation at the parking site. Sufficient air circulation is especially important for the underbody. Moisture or lack of oxygen can lead to impairments	
Treat rubber seals with a conventional rubber care product	
Observe the instructions in the instruction manual of the base vehicle	

	Additional measures for winter lay-up	Done
	For diesel vehicles, fill the fuel tank with winter diesel	
	Clean body and underbody thoroughly and spray with hot wax or protect with varnish	
	Rectify damage to the paintwork	
	Check the radiator frost protection and top up if necessary	
	Check the frost protection of the windscreen washer system and top up if necessary	
Body (outside)	General lay-up measures	Done
	<p>All vents should be sealed with the appropriate caps and all other openings (apart from forced ventilations) should also be sealed. This prevents animals (e.g. mice) from gaining entry</p> <p>To prevent the formation of condensation and subsequently mould: Ventilate the interior, all storage space accessible from the outside and the parking site (e.g. garage) every 3 weeks</p>	
	Additional measures for winter lay-up	Done
	 ▷ Keep the forced ventilation open. Arrange the covers in such a way that the ventilation openings are not covered, or use porous tarpaulins	
	Clean vehicle from outside thoroughly	
	Clean and grease installed supports	
	Clean and grease all door and flap hinges	
	Brush oil or glycerine on all locking mechanisms	
	Use graphite dust to treat locking cylinders	
	Treat all rubber seals with a conventional rubber care product	
Body (inside)	General lay-up measures	Done
	Place upholstery in an upright position for ventilation, and cover	
	Clean the refrigerator (and the freezer compartment) and move doors to ventilation position (see the manufacturer's instruction manual)	
	Disconnect the projector from the mains	
	Open the roller blinds and thereby relieve the springs	
	Additional measures for winter lay-up	Done
	Set up the de-humidifier (granulate)	
	Store cushions and mattresses in a dry place	
	Empty all cabinets and storage compartments, open flaps, doors and drawers	
	Thoroughly clean the interior	
	Air the interior every 3 weeks	
	If there is a risk of frost, remove the projector from the vehicle	

Gas system	General lay-up measures	Done
	Close the regulator tap on the gas bottle	
	Close all gas isolator taps	
	Always remove gas bottle from the gas bottle compartment, even if it is empty	

Water system	General lay-up measures	Done
	 ▷ Never operate water pump without water.	
	Empty the fresh water system. Blow out residual water from the pipes (max. 0.5 bar)	
	Clean the fresh water system using suitable cleaning agents from a specialised store. Open all drain cocks and water taps to empty (see section 10.2.5)	
	Leave the water taps on in central position. Leave all drain cocks open.	
	Clean the waste water tank (do not forget the probe) and empty it (see section 11.10.4), leave the drain cock open	

Additional measures for winter lay-up	Done
If possible, empty siphons at the sink and wash basin to prevent freezing	

- Electrical system** The electrical system of a motorhome consists of two separate supply circuits:
- Starter battery, starter motor and alternator (generator)
 - Living area battery, transformer/rectifier (EBL) and operating panel

General lay-up measures	Done
Clean the battery terminals of the starter battery	
If necessary, top up the battery water of the starter battery	
Fully charge starter battery via external charger	
Activate vehicle hibernation (see section 11.12.3)	
Observe the instructions regarding the starter battery in the instruction manual of the base vehicle	
Fully charge the living area battery via the on-board charger (the charging time depends on the equipment). Charge the battery at temperatures above 0 °C so that the battery can also absorb capacity	
Remove the fuse from the water pump on the transformer/rectifier	
Disconnect the living area battery from the 12 V power supply. In order to do this, switch off the transformer/rectifier at the main switch	
Check the voltage of the batteries periodically during the lay-up period. If the battery voltage drops below 12.5 V: recharge the battery	

Additional measures for winter lay-up	Done
Remove the starter battery and the living area battery and store them in a place protected from frost or connect the vehicle to a 230 V supply. Prior to the removal, remove the fuses on the living area battery	

11.12.3 Activating the vehicle's hibernation mode



- ▶ Comfort functions drain current from the starter battery even when the vehicle is stationary and the transformer/rectifier has been switched off. This may cause starting problems after longer periods of inactivity.

If the vehicle has been set to hibernation mode, the power consumption is reduced to a minimum. This protects the starter battery. Thereby, the vehicle can be easily started after longer periods of inactivity.

Activating the hibernation mode:

- Depending on the equipment, activate the hibernation mode on the MBUX display or on the electronic instrument cluster via the steering wheel buttons. The operation is described in the operating manual of the base vehicle.

Cancelling the hibernation mode:

- Switch on ignition. The hibernation mode ends when switching the ignition on, and must be activated again if necessary.

11.12.4 Starting up the vehicle after a temporary lay-up or after lay-up over winter



- ▷ On vehicles with a battery capacity indicator, the data are reset when the main switch on the transformer/rectifier is switched off. Therefore, when putting the system back into operation, a complete charging cycle must be carried out in order to calibrate the system. In addition, the date and time must be reset.

Go through the following checklist before start-up:

	Activity	Done
Base vehicle	If the vehicle has been stationary for a longer period (approx. 10 months) have the braking system checked by an authorised specialist workshop	
	Check tyre pressure of spare wheel, if present	
	Check the tyre pressure on all tyres	
Body	Clean the pivot bearing of the entrance step	
	Check the functioning of the fitted supports	
	Check that the doors, windows and skylights are working properly	
	Check the function of all external locks, e.g. the storage flaps, the filler necks and the living area door	
	Search for traces of animals that have gained entry	
	Remove the cover from the waste gas vent of the heater (if there is one)	

	Activity	Done
Gas system	If the vehicle has been stationary for a longer period (approx. 10 months) have the gas system checked by an authorised specialist workshop	
	Put the gas bottle in the gas bottle compartment, tie down and connect to the gas pressure regulator	
Electrical system	Connect to 230 V external power supply	
	Install the living area battery and starter battery, insert the fuses on the living area battery and fully charge the battery	
	 ▷ Charge the battery for at least 20 hours after lay-up.	
	Connect the living area battery with the 12 V power supply. To do this, switch on the battery cut-off switch/rectifier (see chapter 8)	
	Check that the electrical system are working, e.g. interior light, socket and all installed electrical appliances	
Water system	Disinfect water pipes and water tank	
	Check the functionality of the operating lever for the waste water tank	
	Close all drain cocks and water taps	
	Check water system for leaks	
Appliances	Check the function of the appliances	

Chapter overview

This chapter contains instructions about official inspections and inspection and maintenance work in the vehicle.

At the end of the chapter you will find important instructions on how to obtain spare parts and on our dealers and service centres.

12.1 Service and sales partners

The authorised service and sales partners are the contacts when spare parts are needed or/and repairs are required.

You will find the addresses and telephone numbers of the authorised service and sales partners at:

Hymer: on the Internet at <https://www.hymer.com/de/en/service/dealer-search>

Mercedes: on the Internet at <https://www.mercedes-benz.de/vans/de/content-pool/apps/dealer-locator>



- ▷ Before starting your journey, check what options are available to you in the event of a breakdown.
- ▷ Observe that the manufacturer's service and mobility commitments are not valid at all destinations.
- ▷ In the case of travelling to countries without a service partner, you travel at your own risk.

12.2 Official inspections

Depending on the national legislative provisions, the following official inspections must be carried out periodically:

- Main inspection
- Emissions test
- Inspection of the gas system

The inspection intervals in accordance with the national legislative provisions must be adhered to. The inspection stickers attached to the vehicle indicate when the next inspection is required.

For Germany, for example, the following regulation applies:

From April 1st 2022, the inspection obligation for the gas system as part of the main inspection (HU) will no longer apply. Instead, an independent gas inspection (according to DVGW (German Technical and Scientific Association for Gas and Water) worksheet G 607) must be carried out for recreational vehicles (motorhomes and caravans). The gas inspection is evidenced by the correctly completed yellow inspection book and a valid inspection sticker on the vehicle.

For more information on the gas inspection and the intervals at which it must be carried out, see the following websites:

- German Federal Ministry of Digital Affairs and Transport (BMDV): www.bmvi.de
- German Technical and Scientific Association for Gas and Water (DVGW): www.dvgw.de
- German Association for Liquefied Gas (DVFG): www.dvfg.de

As long as the intervals at which the gas inspection must be carried out are not regulated by law, the DVGW recommends an inspection every two years.

Many camping site operators demand proof of a valid gas inspection when allocating a parking place.



- ▷ Any changes on the gas system must be carried out by a certified expert for gas systems.
- ▷ Even in the case of vehicles that are not registered, an inspection of the gas system is required.

12.3 Inspection work

Like any technical appliance, the vehicle must be inspected at regular intervals.

This inspection work must be carried out by qualified personnel.

Special technical knowledge, which cannot be taught within the framework of this instruction manual, is required for these tasks. Personnel possessing this technical knowledge are available for assistance at all service centres. Their experience and regular technical training by the factory as well as the equipment and tools used guarantee expert and up-to-date inspection of the vehicle.

The service centre in charge will confirm the work performed.

Have chassis inspections confirmed in the chassis manufacturer's customer service booklet.



- ▷ Observe the inspections indicated by the manufacturer and have them carried out at the specified intervals. The value of the vehicle is thus preserved.
- ▷ The confirmation of the inspection work carried out serves as valid proof in the event of damage and guarantee claims.

12.4 Maintenance work

As with every machine, this vehicle requires maintenance. The extent and frequency of the maintenance work required depend on conditions of operation and use. More difficult operating conditions make it necessary to service the vehicle more often.

Have the base vehicle and the appliances serviced at the intervals specified in the corresponding instruction manuals. In general, we recommend carrying out body inspections at the specified intervals. Contact the **HYMER** service partner.

12.5 Air conditioning unit

Clean the lint filter regularly (at least twice a year) and replace it if necessary.

Replace the particulate filter annually before the start of the season.



- ▷ Further information can be obtained in the manufacturer's instruction manual.

12.6 Independent vehicle heater

Use the independent vehicle heater for 10 minutes at least once a month with a cold engine and smallest fan settings.

Before the heating season starts, have the independent vehicle heater checked by an authorised specialist workshop.

12.7 Cooker/refrigerator

The manufacturer recommends a yearly inspection service in a authorised specialist workshop to maintain the appliances' efficiency. After service and maintenance work, the appliance must be checked for electrical safety as well as for gas safety.

12.8 Replacing bulbs, external



- ▶ Bulbs and lamp holders can be extremely hot. Therefore, allow lamps to cool down before changing bulbs.
- ▶ Store bulbs in a safe place inaccessible to children.
- ▶ Do not use any bulb that has been dropped or which shows scratches in its glass. The bulb might burst.



- ▷ Do not touch a new bulb with bare fingers. Use a cloth when installing the new bulb.
- ▷ Only use bulbs of the same type and with the correct wattage.
- ▷ If LEDs in lamps are defective, contact an authorised dealer or service centre.

12.8.1 Front lights



- 1 Additional main beam
- 2 Clearance light
- 3 Front lighting

Fig. 147 Front lights

The front lighting (Fig. 147,3) is part of the base vehicle. Changing the illuminants is described in the instruction manual for the base vehicle.

The two white clearance lights (Fig. 147,2) and the additional main beam (Fig. 147,1) are fitted with LEDs. To change the LEDs, contact an authorised dealer or a service centre.

12.8.2 Rear lights



- ▷ All lamps at the rear of the vehicle are fitted with LEDs. To change the LEDs, contact an authorised dealer or a service centre.
- ▷ The licence plate light is not shown in the following illustrations.

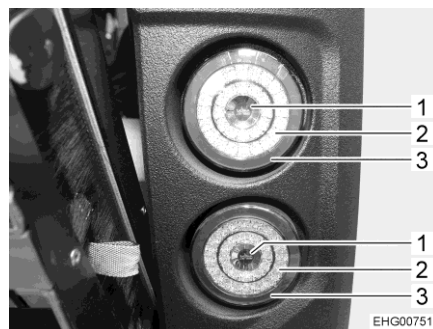

- 1 Direction indicator
- 2 Tail light (white)
- 3 Brake light

Fig. 148 Rear lights unit, round

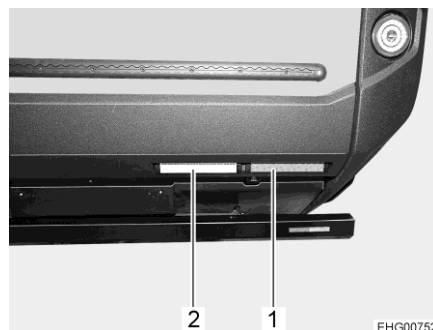

- 1 Fog tail light
- 2 Reverse light

Fig. 149 Rear lights, narrow

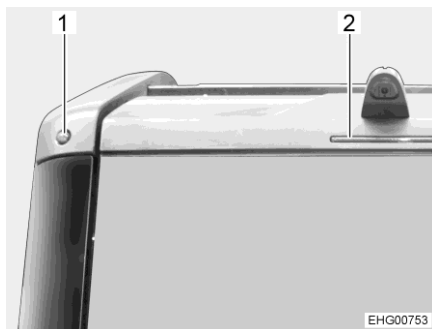

- 1 Side marker light
- 2 Third brake light

Fig. 150 Rear lights, top

12.8.3 Side lights

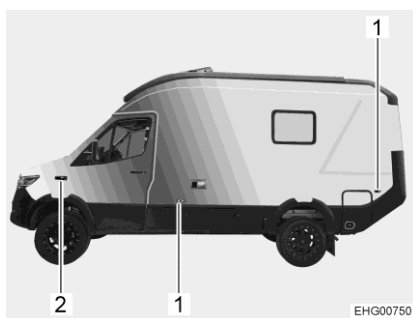

- 1 Marker light
- 2 Direction indicator

Fig. 151 Side lights

Direction indicator

The direction indicator is part of the base vehicle. Changing the illuminants is described in the instruction manual for the base vehicle.

Marker light

The lamp is glued in. If the illuminant is faulty, contact an authorised dealer or service centre.

12.9 Lighting for living area



- ▶ Do not replace the LEDs in lamps with standard light bulbs. Risk of fire due to intense heat build up.

All of the lights in the living area are equipped with LED technology. LED lights are economical, low-maintenance and have a very long life. It is not normally necessary to replace a light.



- ▷ If LEDs in lamps are defective, contact an authorised dealer or service centre.

12.10 Spare parts



- ▶ Every alteration of the original condition of the vehicle can alter road behaviour and jeopardize road safety.
- ▶ The optional equipment and original spare parts recommended by **HYMER GmbH & Co. KG** have been specially developed and supplied for your vehicle. These products are available at the authorised dealer or service centre. The authorised dealer or service centre is informed about admissible technical details and carries out the required work correctly.
- ▶ The use of accessories, parts and fittings not supplied by **HYMER GmbH & Co. KG** may cause damage to the vehicle and jeopardize road safety. Even if an expert's report, a general type approval or a design certification exists, there is no guarantee for the proper quality of the product.
- ▶ No liability can be assumed for damage caused by products which have not been released by **HYMER GmbH & Co. KG**. This also applies to impermissible alterations to the vehicle.

For safety reasons, spare parts for pieces of equipment must correspond with manufacturer's instructions and be permitted by the manufacturer as a spare part. These spare parts may only be fitted by the manufacturer or an authorised specialist workshop. The authorised dealers and service centres are available for any spare parts requirement.

Here are some examples of important spare parts:

- Fuses
- Bulbs
- Water pump (submerged pump)

When ordering spare parts, please indicate the serial number and the vehicle type to the authorised dealer or service centre.

The vehicle described in this instruction manual is built and equipped to factory standards. Optional equipment is offered depending on its purpose or use. When fitting optional equipment check if such equipment has to be entered in the vehicle documents. Observe the technically permissible maximum laden mass. The authorised dealer or service centre will be happy to advise you.

12.11 Vehicle identification plate

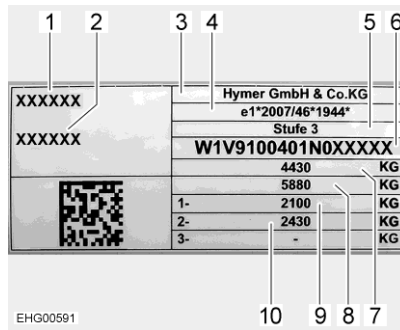

- 1 Vehicle type
- 2 Consecutive serial number
- 3 Manufacturer
- 4 Vehicle type approval
- 5 Body stage
- 6 Chassis number
- 7 Technically permissible maximum laden mass
- 8 Permissible total towing mass (with caravan coupling option)
- 9 Technically permissible maximum laden mass on axle 1
- 10 Technically permissible maximum laden mass on axle 2

Fig. 152 Vehicle identification plate

The vehicle identification plate with the serial number is attached to the rear wall underneath the right-hand rear light.

Do not remove the vehicle identification plate. The vehicle identification plate:

- identifies the vehicle
- helps with the procurement of spare parts
- together with the vehicle documents identifies the vehicle owner



▷ Always include the **serial number** with all inquiries for the customer service office.

12.12 Warning and information stickers

There are warning and information stickers on and inside the vehicle. Warning and information stickers are for the sake of safety and must not be removed.



▷ Replacement stickers can be obtained from an authorised dealer or a service centre.

12.13 Dealers

Contact your authorised dealer or service centre whenever spare parts are needed for the vehicle.

You can find the addresses and telephone numbers of the authorised dealers and service centres:

- In the brochure, which is included separately with the vehicle
- In the Internet at <http://www.hymer.com>

12.14 Replacement keys

To order replacement keys make a note of the following:

Locks for:	To order keys you need:	Obtainable at:
Mercedes-Benz base vehicle	Chassis number, proof of ownership	Mercedes-Benz authorised workshop
Body	Serial number, chassis number, second key or key number, proof of ownership	Dealers

Chapter overview

This chapter contains instructions regarding the tyres of the vehicle.

At the end of the chapter there is a table you can use to find the correct tyre pressure for your vehicle.

13.1 General



- ▶ Check tyre pressure before a journey or every 2 weeks. Wrong tyre pressure causes excessive wear and can lead to damage or even to tyre burst. You can lose control of the vehicle (see section 13.8).



- ▷ Check the tyre pressure on cold tyres. Do not reduce the higher tyre pressure when the tyres are warm.
- ▷ Tubeless tyres have been installed on the vehicle. Never install tubes in these tyres.
- ▷ Read the instruction manual for the base vehicle.



- ▷ The vehicle is equipped with a tyre repair kit as standard.
- ▷ In the case of a puncture, pull the vehicle over to the side of the road. Make vehicle safe with a hazard warning triangle. Switch on the warning lights.
- ▷ Tyres must not be older than 6 years as the material will become brittle over time. The four-digit DOT number on the tyre flank indicates the date of manufacture. The first two digits designate the week, the last two digits the year of manufacture.

Example: (0723) Week 07, year of manufacture 2023

- Observe:**
- Check the tyres regularly (every 2 weeks) for equal tread wear, tread depth and external damage.
 - Replace tyres at the latest, when the minimum depth of tread stipulated by law is reached.
 - Always use tyres of the same model on one axle.
 - Observe the instructions in the vehicle documents.
 - Only use tyres approved for the wheel rim type fitted. The permitted rim and tyre sizes are quoted in the vehicle documents and the authorised dealer or service centre will always be glad to give you advice.
 - Run-in new tyres for approx. 100 km (60 miles) at low speed since only then do they reach full strength.
 - Check regularly that the wheel nuts or wheel bolts are firmly seated.
 - For lay-ups or long periods of inactivity, keep the tyres and tyre bearings free from pressure points:
Jack up the vehicle so that the wheels do not bear any load, or move the vehicle every 4 weeks in such a way that the position of the wheels is changed.

13.2 Tyre selection



▶ A wrong tyre can damage the tyres during the journey and even cause it to burst.



▷ If tyres that are not approved for the vehicle are used, then the type approval for the vehicle and subsequently the insurance coverage can lapse. The authorised dealer or service centre will be happy to advise you.

The tyre sizes approved for the vehicle are given in the vehicle documents or can be obtained from the authorised dealers or service centres. Each tyre must fit the vehicle on which it will be driven. This applies to the external dimensions (diameter, width), which are indicated with the standardised size designations. In addition, the tyres must meet the requirements of the vehicle with regard to weight and speed.

The weight is based on the technically permissible maximum laden mass on the axle, which is distributed between two tyres. The maximum load-carrying capacity of a tyre is indicated by its load index (= LI, load index code).

The maximum permissible speed for a tyre (with full load-carrying capacity) is indicated by the speed index (= SI). Together, load index and speed index form the operating code of a tyre. This is an official component of the complete, standardised dimensions description which appears on every tyre.

13.3 Tyre specifications

**215/70 R 15C
109/107 Q (example)**

Description	Explanation
215	Tyre width in mm
70	Height-to-width proportion in percent
R	Tyre design (R = radial)
15	Rim diameter in inches
C	Commercial (transporter)
109	Load index code for single tyres
107	Load index code for twin tyres
Q	Speed index (Q = 160 km/h)

13.4 Deep tread tyres – LT 245/75 R16 120/116 S



- ▶ Do not drive the vehicle faster than 120 km/h although the tyre has an approval for up to 180 km/h (= speed index S).
- ▶ Please note that, when using the tyre LT 245/75 R16 120/116 S, the braking distance is longer compared to the standard tyres. The function of the emergency brake assistant may be restricted.
- ▶ Observe further safety instructions regarding tyres and wheels in the instruction manual of the vehicle.



- ▷ The Mercedes Sprinter with 4-wheel drive has been designed as traction 4-wheel vehicle and not as off-road 4-wheel vehicle. If the vehicle is driven off road, the chassis may be damaged. This is true particularly in the case of driving in ruts (e.g. in the forest).
- ▷ The maximum depth of a body of water that a vehicle can pass through without being damaged is called the "wading depth". The maximum wading depth is determined by the lower edge of the bumper, but is a maximum of 40 cm. This applies to all loading conditions. Never cross deeper bodies of water. Water and dirt can damage the vehicle. The driver must make sure that no equipment can be damaged before driving through bodies of water or mud and before driving over raised obstacles. For further details, refer to the Mercedes Benz instruction manual.

Required tyre pressures, see section 13.8.

13.5 Handling of tyres

- Drive over kerbs at an obtuse angle. Otherwise the flanks of the tyres may get pinched. Driving over a kerb at a sharp angle can damage the tyre and result in it getting ruptured.
- Drive over high manhole covers at a slow speed. Otherwise the tyres may get pinched. Driving over a high manhole cover at high speed can damage the tyre and result in it getting ruptured.
- Check the shock absorbers regularly. Driving with poor shock absorbers significantly increases wear.
- In the event of an uneven thread wear, contact customer service.
- Do not clean the tyres with a high-pressure cleaner. The tyres can suffer serious damage within just a few seconds and rupture as a result.

13.6 Repair kit



- ▶ Observe the safety instructions in the manufacturer's instruction manual.

The vehicle is equipped with the TyreKit breakdown kit as standard. Take further information from the manufacturer's instruction manual.

13.7 Changing wheels

13.7.1 General instructions



- ▶ The vehicle must be on level, firm ground, secure from slipping.
- ▶ Go into first gear. Shift the automatic transmission to position "P".
- ▶ Before jacking up the vehicle firmly apply the handbrake.
- ▶ Prevent the vehicle from rolling away by blocking the opposite wheel with the wheel chocks.
- ▶ Under no circumstances jack the vehicle with the fitted supports.
- ▶ If a trailer is connected: Detach the trailer before lifting the vehicle.
- ▶ Position the vehicle jack at the designated mounting points.
- ▶ Never overload the vehicle jack. The maximum permissible load is specified on the vehicle jack's identification plate.
- ▶ Use the vehicle jack only for lifting the vehicle briefly while changing the tyre.
- ▶ Do not start the motor while the vehicle is jacked up.
- ▶ Whilst the vehicle is in a jacked up position, persons must not lie down under it.



- ▷ Do not damage the thread of the thread bolt or wheel bolt when changing the wheel.
- ▷ Tighten the wheel nuts or wheel bolts cross-wise.
- ▷ If you are converting to other rims (e.g. aluminium rims or wheels with winter tyres), use the appropriate wheel bolts with the correct length and spherical shape. Otherwise the wheels may not be securely fixed or the braking system may not work correctly.
- ▷ All 4 wheels must be of the same model and size and be approved for the vehicle.
- ▷ Wheel rims or tyres that are not approved for the vehicle can jeopardize road safety and they must be separately inspected and approved by an accredited test centre.
- ▷ Do not replace wheels cross-wise.



- ▷ Protect the vehicle according to the national regulations, e.g. with a hazard warning triangle.
- ▷ Before changing the wheel, check the wheel rim and tyre size, the max. tyre load and the speed index on the tyres. Only use the wheel rim and tyre sizes stated in the vehicle documents.
- ▷ The on-board tool set is adapted to the mounted wheel nuts or wheel bolts. When alloy wheel rims are mounted, carry an appropriate tool for the spare wheel (steel wheel rim) in the vehicle.
- ▷ Further information can be found in the instruction manual of the base vehicle.

The on-board tool set is stored in the footwell of the driver's cabin under the floor plate.

13.8 Tyre pressure



- ▶ Tyres overheat if the tyre pressure is too low. This can cause serious tyre damage.
- ▶ Check tyre pressure before a journey or every 2 weeks. Wrong tyre pressure causes excessive wear and can lead to damage or even to tyre burst. You can lose control of the vehicle.
- ▶ Use only valves that are approved for the specified tyre pressure.



- ▷ Check the tyre pressure on cold tyres. Do not reduce the higher tyre pressure when the tyres are warm.

The payload and the durability of tyres is directly dependent on the tyre pressure. Air is a volatile medium. It is unavoidable that it will escape from tyres.

As a rule of thumb it can be assumed that a filled tyre loses pressure at a rate of 0.1 bar every two months. To prevent the tyres becoming damaged or burst, check the tyre pressure regularly.



- ▷ The information on pressure levels is valid for cold tyres and loaded vehicles.
- ▷ Pressure in hot tyres must be 0.3 bar higher than in cold tyres. Recheck the pressure when the tyres are cold.
- ▷ Tyre pressures in bar.
- ▷ Over 4.75 bar requires a metal valve.
- ▷ The tyre pressure tolerance is +/- 0.05 bar.
- ▷ Refer to the vehicle documents for the permissible maximum mass on the axles.
- ▷ Only the tyre inflation pressure values in this instruction manual apply even if the base vehicle manufacturer indicates other values.

The vehicles are constantly brought up to the newest technical standards. It is possible that new tyre sizes are not yet included in this table. If this is the case, any authorised dealer or service centre will be happy to provide the newest values.

4-wheel drive

Tyre size	Tyre manufacturer	Air pressure front axle		Air pressure rear axle	
		Perm. mass on the axle ¹ 1860 kg	Perm. mass on the axle ¹ 2000 kg	Perm. mass on the axle ¹ 2250 kg	Perm. mass on the axle ¹ 430 kg
LT 245/75 R16 (deep tread)	All	3.6 bar	3.6 bar	4.8 bar	4.8 bar
LT 265/60 R18	All	3.6 bar	3.6 bar	4.8 bar	4.8 bar

¹ Technically permissible maximum laden mass on the axle



▷ Technically permissible maximum laden mass on the axle, see vehicle identification plate.

Chapter overview

This chapter contains instructions about possible faults in your vehicle. The faults are listed with their possible causes and corresponding remedies. The specified faults can be remedied with relative ease and without a great deal of specialised knowledge. In the event that the remedies detailed in this instruction manual should not be successful, an authorised specialist workshop or the manufacturer must find and eliminate the cause of the fault.

14.1 Braking system



- ▶ Have defects on the braking system immediately remedied by an authorised specialist workshop.

14.2 Electrical system



- ▷ See chapter 8 for changing the fuses.

Fault	Cause	Remedy
Road light system does no longer work correctly	Illuminant defective	Contact customer service
	Fuse is defective	Contact customer service
Interior lighting does not work	Illuminant, plug connector or cable faulty	Contact customer service
The electrically operated entrance step cannot be moved in or out	Fuse on the transformer/rectifier is defective	Replace fuse on the transformer/rectifier
The entrance step does not extend or only partially (in the winter)	The mechanics are iced up. The protection device (pinch protection) has triggered due to a overload current	Clean the entrance step, remove ice
No 230 V power supply in spite of connection	230 V automatic circuit breaker has triggered	Switch on 230 V automatic circuit breaker
Starter or living area battery is not charged when operated in 230 V mode	Fuse on the starter battery or on the living area battery is defective	Replace fuse on the starter battery or on the living area battery
	No mains voltage	Switch on automatic circuit breaker in the vehicle
	Transformer/rectifier is overheated	Ambient temperature too high or transformer/rectifier ventilation hindered
	Charger module in the transformer/rectifier and AC converter defective	Contact customer service

Fault	Cause	Remedy
Living area battery is not charged during vehicle operation	Fuse on terminal D+ of the alternator is defective	Replace fuse
	Charge booster is defective	Contact customer service
The 12 V indicator lamp does not light up	12 V power supply is switched off	Switch 12 V power supply on
	Battery cut-off switch on the transformer/rectifier is switched off	Switch on the battery cut-off switch
	Starter or living area battery is not charged	Charge the starter or living area battery
	Fuse on the living area battery is defective	Replace fuse on the living area battery
12 V power supply does not work	12 V power supply is switched off	Switch on the 12 V power supply
	Battery cut-off switch on the transformer/rectifier is switched off	Switch on the battery cut-off switch
	Living area battery is discharged	Charge the living area battery
	Fuse on the living area battery is defective	Replace fuse on the living area battery
12 V power supply does not work in 230 V operation	12 V power supply is switched off	Switch 12 V power supply on
	Battery cut-off switch on the transformer/rectifier is switched off	Switch on the battery cut-off switch
	230 V automatic circuit breaker has triggered	Contact customer service
	Charger module in the transformer/rectifier is defective	Contact customer service
	Fuse on the living area battery is defective	Replace fuse on the living area battery
Mains check symbol does not light up even though 230 V mains supply is connected	The mains connection is de-energised	Check external mains connection
	230 V automatic circuit breaker upstream of transformer/rectifier has tripped or is switched off	Reset 230 V automatic circuit breaker

Fault	Cause	Remedy
No voltage at a connected appliance	Self-resetting Polyswitch fuse has tripped	Check plug connectors and cables. Switch off 12 V power supply for approx. 2 minutes, then switch it back on
	Self-resetting Polyswitch fuse has tripped several times (3 times), system has deactivated corresponding output permanently	Remedy cause of Polyswitch tripping Cancel permanent switch-off (switch on 12 V power supply for living area, press rotary knob and keep it pressed for minimum 3 seconds)
No voltage is supplied by the living area battery	Living area battery is discharged	Charge living area battery immediately
	Battery has switched off to protect against deep discharge	Fully charge the living area battery before the vehicle is parked for a longer period of time, discharging takes place via silent consumers (see chapter 8)
Battery charge through solar module not working	Electrical connection to solar module interrupted	Check plug connectors and cables
	Fuse is defective	Replace fuse
	Solar charge regulator is defective	Contact customer service

14.3 AC converter

Fault	Cause	Remedy
Sockets without voltage	The AC converter has switched itself off due to a fault	If the AC converter does not start again after some time, contact the customer service
	The circuit breaker in the AC converter has tripped	Switch the circuit breaker on

14.4 Gas system



- ▶ In case of a defect of the gas system (gas odour, high gas consumption) there is danger of explosion! Close regulator tap on the gas bottle immediately. Open doors and windows and ventilate well.
- ▶ If the gas system is defective: Do not smoke; do not ignite any open flames, and do not operate electric switches (light switches etc.). Check the tightness of gas-conducting parts and lines with leakage search spray. Do not check with an open flame.
- ▶ Have the defective gas system repaired by an authorised specialist workshop.

Fault	Cause	Remedy
No gas	Gas bottle is empty	Change gas bottle
	Gas isolator tap closed	Open the gas isolator tap
	Regulator tap on the gas bottle is closed	Open the regulator tap on the gas bottle
	External temperature is too low (-42 °C for propane gas, 0 °C for butane gas)	Wait for higher external temperatures
	Built-in appliance is defective	Contact customer service

14.5 Cooker

Fault	Cause	Remedy
Ignition fuse does not operate (flame does not burn after the control knobs are released)	Heat-up time is too short	Keep control knob pressed for approx. 15 to 20 seconds after ignition
	Ignition fuse is defective	Contact customer service
Flame extinguishes when being reduced to its minimum setting	Thermocouple sensor is incorrectly set	Correctly reset thermocouple sensor (do not bend). The sensor tip should protrude by 5 mm beyond the burner. The sensor neck should not be more than 3 mm away from the burner ring; if necessary, contact customer service

14.6 Heater/boiler

In the event of a defect contact the nearest customer service workshop of the relevant appliance manufacturer. The list of addresses is enclosed with the accompanying appliance documentation. Only authorised qualified personnel may repair the appliance.

14.6.1 Heater/boiler with CP plus digital control unit



- ▷ Observe the notes and information on the subject of malfunctions/troubleshooting in the separate instruction manual from the manufacturer.

Fault	Cause	Remedy
Heater does not ignite	Temperature sensor on control unit or remote sensor defective	Pull out plug on control unit. The heater then works without thermostat. Contact the customer service as soon as possible
No display on control unit	Fuse on the transformer/rectifier is defective	Replace fuse on the transformer/rectifier
	Fuse in the electronic control unit has been triggered	Contact customer service
	Living area battery defective	Charge or replace the living area battery (or have it charged or replaced)
Fault with error code is displayed	See table "Fault search instruction"	See table "Fault search instruction"
Boiler empties, safety/drainage valve has opened	Internal temperature below 8 °C	Heat inside
Safety/drainage valve cannot be closed	Temperature at safety/drainage valve below 8 °C	Heat inside
Fan wheel runs noisily or not steadily	Fan wheel is soiled	Contact Truma service department

Fault search instruction

Error code	Cause	Rectification
E 111 H	Room temperature sensor or cable defective	Contact customer service
E 122 H	Fuel shortage (fuel tank empty or vehicle at an angle)	Refill fuel
E 131 H	No connection between heater and control unit	Contact customer service
E 150 H	Not all hot air pipes connected	Contact customer service
	Warm air louvres blocked	Check outlet openings
	Air circulation suction system blocked	Remove blocking
E 151 H E 152 H	Overtemperature in the water tank	Switch off the device and allow it to cool down. Fill the boiler with water
	Warm air louvres blocked	Check outlet openings
	Air circulation suction system blocked	Remove blocking
E 160 H	Undervoltage < 10.2 V	Check battery voltage, charge battery if necessary or have battery replaced
		Switch off appliances or start vehicle engine until heater is running (approx. 4 minutes)
E 161 H	Overvoltage > 16.4 V	Check battery voltage and voltage sources (e.g. charger)
E 162 H	Safety switch has triggered	(Not used here)
E 164 H	No 230 V power supply	Check external mains connection
	230 V automatic circuit breaker has triggered	Switch on 230 V automatic circuit breaker
	Overheating protection has triggered	Reset overheating protection. Allow the heater to cool. Remove connection cover and press reset button
E 170 H	Risk of undervoltage < 11.5 V	Charge the battery
W 255 H	No 12 V power supply	Check power supply
	No connection between heater and control unit	Contact customer service

If these measures do not rectify the fault, contact customer service.

14.7 Air conditioning unit

Fault	Cause	Remedy
Air conditioning unit not running, red LED on infrared receiver is lit	Fault	Switch off the air conditioning unit, wait a short time and switch on again. If the red LED remains lit: Contact customer service
Air conditioning unit not cooling at all or not sufficiently	Defrosting in progress	Wait until defrosting has finished
	Room temperature has reached set temperature	Set a temperature that is lower than the room temperature
	Filter dirty	Clean/replace the filter
Supply air openings soiled/blocked		Clean supply air openings
	Remote control is not working	Remote control batteries empty
Air conditioning unit does not respond to remote control commands	Obstacle between remote control and infrared receiver	Remove obstacle
Moisture on cold air pipes	High humidity	Close windows and doors, select high fan speed

14.8 Refrigerator

14.8.1 General

In the event of a defect contact the nearest customer service workshop of the relevant appliance manufacturer. The list of addresses is enclosed with the accompanying appliance documentation. Only authorised qualified personnel may repair the appliance.



- ▷ If the refrigerator has visible damage, it must not be put into operation.



- ▷ Further information can be obtained in the manufacturer's instruction manual.

Fault	Cause	Remedy	
Refrigerator does not switch on	Thermostat is in STOP position	Adjust higher value on thermostat	
Compressor does not run	No supply voltage	Charge the battery Contact customer service if necessary	
	Battery voltage too low	Charge the battery	
	Battery capacity too low	Change the battery	
	Ambient temperature is too high	If possible, ensure a lower ambient temperature (e.g. park the vehicle in the shade)	
	Ventilation insufficient		Keep the ventilation slots clear
			Contact customer service if necessary
Cooling power decreases, internal temperature increases	Ambient temperatures are too high	If possible, ensure a lower ambient temperature (e.g. park the vehicle in the shade)	
	Ventilation insufficient	Keep the ventilation slots clear	
		Contact customer service if necessary	
	Battery capacity low	Charge the battery	
Refrigerator is cooling very intensely	Set cooling level is too high	Set lower cooling level	
Refrigerator does not switch off	Temperature in the refrigerator too high	Check if refrigerator door is closed	
Unusual noises	The vehicle is not in a horizontal position	Set the vehicle up in a horizontal position	

14.9 Water supply

Fault	Cause	Remedy
Leakage water inside the vehicle	A leak has occurred	Identify leak, re-connect water pipes
No water	Water tank is empty	Replenish drinking water
	Drain cock not closed	Close drain cock
	12 V power supply is switched off	Switch 12 V power supply on
	Switch for water pump is off	Switch water pump on
	Fuse of the water pump is defective	Replace fuse on the transformer/rectifier
	Water pump defective	Exchange water pump (have it exchanged)
	Water pipe snapped off	Straighten water pipe or replace
	Transformer/rectifier defective	Contact customer service
Toilet has no flush water	Water tank is empty	Replenish drinking water
Display for water and waste water indicates a wrong value	Measuring probe in the waste water or water tank is soiled	Clean water/waste water tank
	Measuring probe is defective	Replace measuring probe
Waste water tank cannot be emptied	Drain cock is clogged	Open the cleaning cap on the waste water tank and drain the waste water. Rinse the waste water tank well
Drain on the single lever mixer tap is clogged	Perlator calcified	Unclip the perlator, de-calcify in vinegar water (only for products made from metal)
Water jets on the shower nozzle clogged	Water jets calcified	De-calcify shower nozzle in vinegar water (only for products made from metal) or rub off soft nozzle burling
Water drains from the shower tray slowly or does not drain at all	The vehicle is not in a horizontal position	Position the vehicle horizontally
Milkiness of the water	Tank filled with dirty water	Clean water tank mechanically and chemically; then disinfect and rinse copiously with drinking water
	Residues in the water tank or water system	Clean water system mechanically and chemically; then disinfect and rinse copiously with drinking water

Fault	Cause	Remedy
Any change in the taste or odour of the water	Tank filled with dirty water	Clean water system mechanically and chemically; then disinfect and rinse copiously with drinking water
	Fuel filled into the water tank by mistake	Clean water system mechanically and chemically; then disinfect and rinse copiously with drinking water. If not successful: Contact a specialist workshop
	Microbiological deposits in the water system	Clean water system mechanically and chemically; then disinfect and rinse copiously with drinking water
Deposits in the water tank and/or water-carrying components	Water excessively long in the water tank and in water-carrying components	Clean water system mechanically and chemically; then disinfect and rinse copiously with drinking water

14.10 Body

Fault	Cause	Remedy
Flap hinges/door hinges are difficult to operate	Flap/door hinges are not (sufficiently) lubricated	Lubricate flap hinges/door hinges with acid-free and resin-free grease
Hinges/joints in the bathroom unit/toilet compartment are difficult to operate/make a grating noise	Hinges/joints are not (sufficiently) lubricated	Lubricate hinges/joints with solvent-free and acid-free grease  ▷ Spray cans often contain solvents
Storage compartment hinges are difficult to operate/make a grating noise	Storage compartment hinges are not (sufficiently) lubricated	Lubricate storage compartment hinges with acid-free and resin-free grease



▷ The authorised dealers and service centres are available for any spare parts requirement.

15.1 Weight details for optional equipment



- ▶ The use of accessories, parts and fittings not supplied by **HYMER GmbH & Co. KG** may cause damage to the vehicle and jeopardize road safety. Even if an expert's report, a general type approval or a design certification exists, there is no guarantee for the proper quality of the product.
- ▶ Every alteration of the original condition of the vehicle can alter road behaviour and jeopardize road safety.
- ▶ No liability can be assumed for damage caused by products which have not been released by **HYMER GmbH & Co. KG**. This also applies to impermissible alterations to the vehicle.

Depending on the model series, different optional equipments are offered. You can find out which optional equipments are available for your vehicle in the accessories list, which is available separately. There you will also find information on the weights of the individual optional equipments.

16.1 Technical data



- ▷ Only the details provided in the actual vehicle documentation shall be binding with regard to the technical data.
- ▷ The measurements as well as the net weight of the vehicle may change when mounting accessories or optional equipment. Differences due to manufacturing tolerances (+/- 5 %) are possible and admissible.

16.2 Dimensions and permissible number of persons

Wheelbase in cm	Length in cm	Width in cm	Height in cm	Permissi- ble number of persons	Sleeping places
3665	645	216	305	2	2 + 2

Refer to the vehicle documents or the instruction manual of the base vehicle for further information on technical data. The authorised dealers and service centres will also provide information if necessary.

The weight specifications and tests for motorhomes are uniformly regulated throughout the EU in EU Implementing Regulation No. 2021/535 (until June 2022: EU Implementing Regulation No. 1230/2012). We have summarised and explained the key terms and legal requirements from this regulation for you below. Our dealers and the HYMER configurator on our website offer you additional assistance in configuring your vehicle.

1. Technically permissible maximum laden mass

The technically permissible maximum laden mass of the vehicle (e.g. 3,500 kg) is a mass specification set by the manufacturer which the vehicle must not exceed. Information on the technically permissible maximum laden mass of the model you have chosen can be found in the technical data. If the vehicle exceeds the technically permissible maximum laden mass in everyday driving, this constitutes an administrative offence which may result in a fine.

2. Mass in running order

In simple terms, the mass in running order is the basic vehicle with standard equipment plus a legally fixed standard weight of 75 kg for the driver. This essentially includes the following items:

- the unladen weight of the vehicle together with the bodywork, including operating fluids such as greases, oils and coolants;
- the standard equipment, i.e. all equipment items that are included as standard in the factory-fitted scope of delivery;
- the fresh water tank filled to 100 % in driving mode (driving fill according to manufacturer's specifications; 20 litres) and an aluminium gas cylinder filled to 100 % with a weight of 16 kg;
- the fuel tank, which is 90 % full, including fuel;
- the driver, whose weight – regardless of the actual weight – is generally specified as 75 kg in accordance with EU law.

Information on the mass in running order can be found for each model in our sales documents. It is important to note that the value for mass in running order given in the sales documents is a default value determined in the type-approval procedure and verified by the authorities. It is legally permissible and possible for the mass in running order of the vehicle delivered to you to deviate from the nominal value stated in the sales documents. The legally permissible tolerance is $\pm 5\%$. In this way, the EU legislator accounts for the fact that certain fluctuations in the mass in running order occur due to variations in the weight of supplied parts as well as due to processes and weather conditions.

These weight deviations can be illustrated by means of an example calculation:

- Mass in running order acc. to sales documents: 2,850 kg
- Legally permissible tolerance of $\pm 5\%$: 142.50 kg
- Legally permissible range of mass in running order: 2,707.50 kg to 2,992.50 kg

The specific range of permissible weight deviations can be found for each model in the technical data. HYMER makes great efforts to reduce weight variations to the minimum that is unavoidable for production reasons. Deviations at the upper and lower end of the range are therefore very rare; however, they cannot be completely ruled out technically, even with all optimisations. The real weight of the vehicle and compliance with the permissible tolerance is therefore checked by HYMER by weighing each vehicle at the end of the line.

3. Mass of the passengers

The mass of the passengers is set a standard value of 75 kg for each seat provided by the manufacturer, regardless of the actual weight of the passengers. The mass of the driver is already included in the mass in running order (see no. 2 above) and is therefore not included again. In the case of a motorhome with four permitted seats, the mass of the passengers is therefore $3 \times 75 \text{ kg} = 225 \text{ kg}$.

4. Optional equipment and actual mass of the vehicle

Optional equipment (also: additional equipment) includes, according to the legal definition, all optional equipment parts not included in the standard equipment which are fitted to the vehicle under the responsibility of the manufacturer – i.e. ex works – and can be ordered by the customer (e.g. awning, bicycle or motorbike carrier, satellite system, solar system, oven, etc.). Information on the individual or package weights of the optional equipment that can be ordered can be found in our sales documents. Optional equipment in this sense does not include other accessories that are retrofitted by the dealer or you personally after the vehicle has been delivered ex works.

The mass of the vehicle in running order (see no. 2 above) and the mass of the optional equipment fitted to a specific vehicle at the factory are together referred to as the actual mass. You will find the corresponding information for your vehicle after handover under item 13.2 of the Certificate of Conformity (CoC). Please note that this specification also represents a standardised value. Since the mass in running order – as an element of the actual mass – is subject to a legally permissible tolerance of $\pm 5 \%$ (see no. 2), the actual mass may also deviate accordingly from the stated nominal value.

5. Pay-mass and minimum pay-mass

The installation of optional equipment is also subject to technical and legal limits: Only so much optional equipment can be ordered and fitted at the factory that sufficient free weight remains for baggage and other accessories ("pay-mass") without exceeding the technically permissible maximum laden mass. The pay-mass is calculated by subtracting the mass in running order (nominal value according to sales documents, see no. 2 above), mass of the optional equipment and the mass of the passengers (see no. 3 above) from the technically permissible maximum laden mass (see no. 1 above).

The EU regulations stipulate a fixed minimum pay-mass for motorhomes, which must remain as a minimum for baggage or other non-factory-fitted accessories. This minimum pay-mass is calculated as follows:

Minimum pay-mass in kg $\geq 10 \times (n + L)$

Where: "n" is the maximum number of passengers plus the driver and "L" is the overall length of the vehicle in metres.

For a motorhome with a length of 6 m and 4 approved seats, the minimum pay-mass is therefore e.g. $10 \text{ kg} \times (4 + 6) = 100 \text{ kg}$.

To ensure that the minimum pay-mass is maintained, there is a maximum combination of optional equipment that can be ordered for each vehicle model. In the above example with a minimum pay-mass of 100 kg, the total mass of optional equipment for a vehicle with four permitted seats and a mass in running order of 2,850 kg should not exceed 325 kg:

3,500 kg technically permissible maximum laden mass
- 2,850 kg mass in running order
- 3 x 75 kg mass of the passengers
- 100 kg minimum pay-mass
= 325 kg maximum permissible mass of optional equipment

It is important to note that this calculation is based on the default value for mass in running order as defined in the type-approval procedure, without taking into account the permissible weight deviations for mass in running order (see no. 2 above). If the maximum permissible value for the optional equipment of (in the example) 325 kg is almost or completely exhausted, an upward weight deviation can therefore result in the minimum pay-mass of 100 kg being met mathematically using the default value for the mass in running order, although in fact there is no corresponding load capacity. Here, too, an example calculation for a vehicle with four seats, whose real weighed mass in running order is 2 % above the nominal value:

3,500 kg technically permissible maximum laden mass
- 2,907 kg real weighed mass in running order (+ 2 % compared to the stated value of 2,850 kg)
- 3 x 75 kg mass of the passengers
- 325 kg optional equipment (maximum permissible value)
= 43 kg actual load capacity (< minimum pay-mass of 100 kg)

In order to avoid such a situation, HYMER further reduces the maximum permissible weight of the total optional equipment that can be ordered on a model-specific basis. The limitation of optional equipment is intended to ensure that the minimum pay-mass, i.e. the legally prescribed free mass for baggage and retrofitted accessories, is actually available for the vehicle load capacity of the vehicles delivered by HYMER.

Since the weight of a specific vehicle can only be determined when it is weighed at the end of the line, in very rare cases a situation may arise in which the minimum pay-mass at the end of the line is not guaranteed, despite this limitation of optional equipment. In order to guarantee the minimum pay-mass even in these cases, HYMER will check together with your trade partner and you before delivery of the vehicle whether, for example, the vehicle is loaded up, seats are reduced or optional equipment is removed.

6. Effects of tolerances of the mass in running order on the pay-mass

Regardless of the minimum pay-mass, you should note that unavoidable production-related fluctuations in the mass in running order – both upwards and downwards – have a mirror-image effect on the remaining load capacity: If you order our example vehicle (see no. 3. above), for example, with optional equipment with a total weight of 150 kg, the calculated pay-mass based on the default value for the mass in running order is 275 kg. The load capacity actually available may deviate from this value due to tolerances and may be higher or lower. If the mass in running order of your vehicle is, for example, permissibly 2 % higher than stated in the sales documents, the load capacity is reduced from 275 kg to 218 kg:

3,500 kg technically permissible maximum laden mass
- 2,907 kg real weighed mass in running order (+ 2 % compared to the stated value of 2,850 kg)
- 3 x 75 kg mass of the passengers
- 150 kg optional equipment ordered for the specific vehicle
= 218 kg actual load capacity

As a precaution to ensure that the calculated pay-mass is actually given, you should therefore take the possible and permissible tolerances for the mass in running order into account when configuring your vehicle.

We also recommend that you weigh the laden motorhome on a non-automatic scale before each journey and, taking the individual weight of the passengers into account, determine whether the technically permissible maximum laden mass and the technically permissible maximum mass on the axle are observed.

12 V fuses 118
 For the driver's area 118
 Position 119
 12 V power supply 100
 Troubleshooting 190
 12 V socket 100
 230 V connection 47, 115, 116
 Troubleshooting 189
 230 V fuse 120
 230 V fuse box 120
 230 V power supply 115
 230 V power supply see also
 230 V connection 115
 230 V socket 100

A

AC converter 113
 Installation positions 114
 Troubleshooting 191
 Accessories, fitting 14
 Actual vehicle mass 21, 24
 Ad-Blue 43
 Additional main beam 37
 Switching on 37
 Add-on parts see optional equipment 14
 Air chambers, sleeping roof wall, repair 66
 Air conditioning unit 130
 Air circulation 131
 Care 157
 Cold air distribution 133
 Cooling 131
 Infrared receiver 132
 Operating modes 130
 Operation 131
 Position 130
 Soft-start 131
 Switching off 131
 Switching on 131
 Timer 132
 Troubleshooting 195
 Air nozzles 133
 Position 133
 Air outlet nozzles, adjusting 122
 App HYMER Connect 112
 Appliances 121
 Manuals 14
 Armrest, adjustment 42
 Awning 47

B

Bamboo solid wood panels 164
 Care 164
 Cleaning 165
 Basic equipment 21
 Bathroom 145
 Battery see starter battery or
 living area battery 101
 Battery, charging with solar energy 117
 Before the journey 19
 Blind, cleaning 158
 Bluetooth 113
 Mobile device, pairing 113
 Switching on/off 113
 Boiler 121
 Boiler (Truma) 123
 Emptying 127
 Hot water production, switching off 126
 Hot water production, switching on 125
 Operating modes 127
 Safety/drainage valve 126
 Troubleshooting 193
 Water, filling with 127
 Brakes 37
 Check 37, 189
 Braking system, troubleshooting 189
 Butane gas 17, 94

C

Cable reel 116
 Camping chairs 56
 Camping gas bottles, use 18, 95
 Capacity of the battery 100
 Caravan coupling 30
 With detachable ball neck 30
 Care 153
 Air conditioning unit 157
 Bamboo solid wood panels 164
 Blind 158
 Carpet 158
 Engine compartment 156
 Entrance step 157
 External care 153
 Furniture surfaces 158
 GRP add-on parts 155
 High-pressure cleaner, washing with 153
 In the winter 168
 Insect screen 158
 Interior care 158
 Kitchen installation 159
 Lamps 158

Lay-up	169
Leather covers	160
PVC-floor covering.....	158
Refrigerator	159
Roman shade	158
Seat belt.....	158
Sleeping roof.....	162
Stainless steel surfaces	160
Synthetic parts, interior	158
Underbody	155
Upholstery.....	160
Washing	154
Waste water tank	167
Water pipes.....	166
Water system.....	165
Water tank.....	165
When taking out of operation temporarily	169
Windows	154
Windscreen washer system.....	156
Windscreen wipers	156
Carpet, cleaning.....	158
Central locking system.....	67
Remote control	67
Changing wheels	186
Checklist	
Before the journey	33
For commissioning after a lay-up	172
Road safety.....	33
Checks see checklist	33
Child restraint systems.....	40
Circulation fan	123
Cleaning see care	153
Closed circuit current	99
Cold air nozzles	133
Condensation	72, 73
Condensation on the double acrylic glass pane	73
Condensation on the screwed connections in the floor	72
Connecting cable see 230 V connection	116
Control unit, hot-air heater	123
Conventional load	23
Cooker.....	134
Cooker see gas cooker or gas oven	134
 D	
Danger of suffocation.....	13, 72
Darkening screen, rear platform	
Pulling out	58
Pushing in	58
Dealers.....	182
Dimensions.....	201
Dimensions see technical data	201
Direction indicator.....	178, 179
Disposal	
Household waste.....	10
Sewage	10
Waste water	10
Door lock	68, 70
Doors	
Living area door	67
Lock.....	68, 70
Troubleshooting	198
Drain cock, waste water tank	144
Driver's door, outside	
Locking	70
Opening.....	70
Driver's seat.....	41
Armrest, adjustment	42
Backrest, adjustment.....	42
Moving to a lengthways direction	41
Seat cushion, shifting	42
Seat height, adjusting.....	41
Seat inclination, setting	42
Turning into the driving position	41
Driving	35
Driving speed	37
 E	
Electrical system	
230 V connection, troubleshooting.....	189
Explanation of terms	99
Lighting, troubleshooting	189
Safety instructions.....	18
Troubleshooting	189
Energy balance, living area battery	105
Engine compartment, care	156
Entrance step	31, 45
Care.....	157
Warning tone.....	31
Environmental tips.....	10
Exterior lighting	
Check	33
Illuminant, replacing	177
Troubleshooting	189
External care	153
External connection see 230 V connection	47
External flaps.....	71
Flap lock	71
External gas connection	96
External shower.....	145

F

Fault current protection switch 115

FI switch, check 120

Filling the tank 43

Fire

 Extinguishing 13

 Response to 13

Fire prevention 13

Fire risks, avoidance 13

Fixing rails, roof 83

Flap lock

 Closing 71

 Opening 71

Flashing indicator

see direction indicator 178, 179

Flat screen 31

Forced ventilation 13, 72

Front passenger's seat 41

 Armrest, adjustment 42

 Backrest, adjustment 42

 Moving to a lengthways direction 41

 Seat cushion, shifting 42

 Seat height, adjusting 41

 Seat inclination, setting 42

 Turning into the driving position 41

Fuel filler neck 43

Furniture flaps

 Closing 81

 Opening 81

Furniture flaps, troubleshooting 198

Furniture surfaces, cleaning 158

Fuses

 12 V fuses 118, 119

 230 V fuse 115, 120

 For the driver's area 118

G

Gas bottle compartment 17, 94

Gas bottles 94

 Changing 97

 Safety instructions 17, 94

Gas connection, external 96

Gas cooker

 Cleaning 159

 Switching off 135

 Switching on 135

 Troubleshooting 192

Gas isolator tap 95

Gas odour 16, 93, 192

Gas pressure regulator, screw connections 95

Gas system

 Defect 16, 93, 192

 General instructions 16

 No gas 192

 Troubleshooting 192

GRP add-on parts, care 155

H

Handling of tyres 185

Heater 121

 Air outlet nozzles, adjusting 122

 Circulation fan 123

 Hot air distribution 122

 Initial start-up 122

 Troubleshooting 193

Hibernation mode, vehicle, activate 172

High rate of gas consumption 16, 93, 192

High-pressure cleaner, washing with 153

Hinged skylight 77

 Closing 77

 Insect screen 78

 Locking in the ventilation position 78

 Opening 77, 78

 Roman shade 78

Hinged window

 Closing 74

 Continuous ventilation 74

 Insect screen 75

 Opening 74

 Roman shade 75

Hot air distribution 122

Hot air nozzles 133

Hot-air heater 123

 Circulation fan 123

 Control unit 123

 Hot air distribution 129

 Operating modes 127

 Troubleshooting 193

HYMER Connect App 112

I

Illuminant, replacing

 Exterior lighting 177

 Front lights 178

 Living area 179

 Rear lights 178

 Side lights 179

Independent vehicle heater, maintenance 177

Indicator lamp, toilet 149

Information stickers 181

Initial start-up 19

Inner door, troubleshooting 198

Insect screen, cleaning	158	Load see also payload	25
Insect screen, hinged skylight		Lock	
Closing	78	Driver's door	70
Opening	78	External flap	71
Insect screen, rear platform		Furniture flap	81
Pulling out	58	Living area door	68
Pushing in	58	Low beam	178
Insect screen, skylight with fan			
Closing	79	M	
Opening	79	Main beam	178
Insect screen, window		Maintenance work	176
Closing	75	Air conditioning unit	157
Opening	75	Cooker	177
Inspection time limits	175	Independent vehicle heater	177
Inspections	176	Marker light	179
Inspections, official	175	Mass in running order	21
Interior care	158	Mechanical steady legs	
Interior lighting	179	Extending	46
Troubleshooting	189	Length, adjustment	46
		Retracting	46
K		Multifunctional wall	82
Kitchen area	32		
		N	
L		Nose weight	30
Lamps	179		
Cleaning	158	O	
Lay-up		Official inspections	175
General	169	Off-load voltage	99
Temporary	169	Operating modes, air conditioning unit	
Temporary (toilet)	152	(Truma)	130
Leakage water inside the vehicle	197	Operating modes, boiler (Truma)	127
Leather covers, cleaning	160	Operating modes, hot-air heater	127
Lighting	89	Optional equipment	23
Front	178	Certification	9
Illuminant, replacing	177	Description	9
Lamps, cleaning	158	Safety instructions	14
Living area	179	Weights	199
Mobile reading lamp	110	Overloading	25
Pendant light	90		
Reading lamp on the secretary	91	P	
Rear	178	Parking light	178
Side	179	Pendant light	90
Troubleshooting	189	Permissible gross weight see technically	
Living area battery		permissible maximum laden mass	20
Balance of energy	105	Personal equipment	23
Troubleshooting	189, 191	Position	
Living area door	67	12 V fuses	119
Insect screen	70	7" panel	110
Living area door, outside		AC converter	114
Locking	68	Active carbon filter for toilet ventilation	151
Opening	68		
Load	25		

Air conditioning unit 130
 Air nozzles 133
 Button for the call for
 breakdown assistance 36
 Control unit, hot-air heater 123
 Fuse box 120
 Safety/drainage valve boiler 126
 SCU 112
 Starter battery 101
 Transformer/rectifier 108
 Waste water tank 143
 Water filter 143
 Water tank 141
 Propane gas 17, 94
 PVC-floor covering, cleaning 158

R

Ramps 45
 Reading lamp on the secretary 91
 Reading lamp, mobile 110
 Rear axle load 30
 Rear ladder 53
 Pulling out 53
 Pushing in 53
 Rear platform
 Care 165
 Darkening screen 58
 Insect screen 58
 Safety guard 54
 Rear wall 50
 Rear window 57
 Closing 57
 Opening 57
 Refrigerator 47, 135
 Care 159
 Door lock 136
 Operation 136
 Troubleshooting 196
 Remote control, central locking system 67
 Repair kit 185
 Replacement keys 182
 Reversing camera 42
 Risk of frost damage 137, 141
 Road safety 33
 Checklist 33
 Notes for 14
 Roman shade, cleaning 158
 Roman shade, driver's window 43
 Roman shade, front passenger's window 43
 Roman shade, hinged skylight
 Closing 78
 Opening 78

Roman shade, window
 Closing 75
 Opening 75

S

Safety guard protection 65
 Safety guard, rear platform 54
 Safety instructions 13
 Changing wheels 186
 Cooker 134
 Electrical system 18
 Fire prevention 13
 Road safety 14
 Towing 16
 Water system 18
 Safety instructions symbols 9
 Safety knob, hinged window 73
 Safety/drainage valve boiler 126
 Position 126
 Sanitary fittings 137
 SCU, see System Control Unit 111
 Seat belts 39
 Cleaning 158
 Correct fastening 39
 Seating arrangement 38
 Serial number 181
 Service and sales partners 175
 Service cover in the floor 81
 Set of keys 19
 Sewage container
 Emptying 150
 Removal 150
 Shade 62
 Shade, skylight with fan
 Closing 79
 Opening 79
 Shade, sleeping roof
 Closing 62
 Opening 62
 Shelf board 63
 Sink cover 32
 Siphons 167
 Skylight with fan 79
 Aerating 80
 Boost function 80
 Closing 79
 Fan, switching off 80
 Insect screen 79
 Opening 79
 Shade 79
 Venting 80
 Skylights 76

Sleeping roof.....	59, 162	Toilet.....	148
Closing.....	60	Flushing.....	149
Cooling.....	63	Indicator lamp.....	149
Heating.....	63	Temporary lay-up.....	152
Opening.....	60	Troubleshooting.....	197
Safety net.....	61	Winter operation.....	152
Shade.....	62	Topping up the water.....	141
Sleeping roof, cleaning.....	162	Total discharge.....	100
Smart Battery system.....	101	Towing.....	16, 44
Snow chains.....	32	General instructions.....	30
Sockets.....		Safety instructions.....	16
12 V.....	100	Transformer/rectifier.....	107
230 V.....	100	Functions.....	109
USB.....	100	Lay-up.....	109
Solar cells.....	107	Position.....	108
Solar installation.....	117	Troubleshooting.....	
Spare parts.....	180	12 V power supply.....	190
Stainless steel surface, cleaning.....	160	230 V connection.....	189
Starter battery.....		AC converter.....	191
Loading.....	101	Air conditioning unit.....	195
Position.....	101	Battery.....	189
Troubleshooting.....	189	Body.....	198
Start-up.....		Boiler.....	193
After lay-up over winter.....	172	Braking system.....	189
After temporary lay-up.....	172	Electrical system.....	189
Steady legs.....	46	Furniture flaps.....	198
Extending.....	46	Gas cooker.....	192
Length, adjustment.....	46	Gas system.....	192
Retracting.....	46	Heater.....	193
Storage spaces.....	80	Hot-air heater.....	193
Supports see steady legs.....	46	Inner door.....	198
Synthetic parts in the toilet		Lighting.....	189
and living areas, cleaning.....	158	Living area battery.....	189
System Control Unit.....	111	Refrigerator.....	196
Position.....	112	Starter battery.....	189
		Toilet.....	197
		Water supply.....	197
		Tyre change see wheels, changing.....	186
		Tyre specifications.....	184
		Tyres.....	
		Certification.....	184
		Deep tread tyres.....	185
		Excessive wear.....	15, 33, 183, 187
		General instructions.....	183
		Handling.....	185
		Load-carrying capacity.....	186
		Tyre pressure.....	187
		Tyre selection.....	184
T			
Table.....	83		
Conversion to bed foundation.....	83		
Putting up.....	84		
Transport position.....	84		
Tables.....	83		
Tank lid see fuel filler neck.....	43		
Technical data.....	201		
Technically permissible			
maximum laden mass.....	20, 24		
Television.....	31		

U	
Underbody, maintenance.....	155
Upholstery, cleaning	160
USB socket	100
V	
Vehicle identification plate	181
Vehicle lighting see lighting.....	177
Vehicle load capacity	19
Calculation	24
Composition	21
Example calculation.....	21
Vehicle load capacity see also load.....	19
Vehicle, washing	154
Ventilation	72
W	
Warning stickers	181
Warning tone, entrance step.....	31
Washing with a high-pressure cleaner.....	153
Waste water tank	143
Care	167
Cleaning.....	167
Emptying.....	144
Position	143
Troubleshooting	197
Water filter.....	142
Position	143
Water pipes, cleaning.....	166
Water pump	137, 138
Water supply	
General.....	137
Troubleshooting.....	197
Water system	
Care.....	165
Cleaning	165
Disinfect.....	166
Emptying	141
Filling	138
Safety instructions	18
Water tank	
Cleaning	165
Position.....	141
Water quantity, reducing	141
Weight details for optional equipment	199
Wheel chock.....	45
Wheel rim size.....	186
Wheel rim type	183
Windows.....	72
Insect screen	75
Roman shade.....	75
Windows, cleaning	154
Windscreen washer system, care	156
Windscreen wipers, care	156
Winter care	168
Work top extension, kitchen	87

